

MERC-O-TRONIC MODEL 98 OPERATORS MANUAL 6/74

Preface

This is a cleaned up pdf version of the operating instruction for the Model 98 Merc-O-Tronic Analyzer (Serial No 15,000 and up) that was created from a pdf copy I found dated 6/74. The text for the instruction pages has been retyped and the images cleaned up to provide a cleaner and easier to read copy for those individuals who still have a Merc-O-Tronic Model 98 analyzer. As such the text in this document is searchable by using the "Ctrl" and "F" function. I have also included a clear picture of the front of the unit since the original Figure 1 is not the best in quality.

I have left the original index pages but added a new index immediately following this page. There are a few supplement sections at the end so I have listed them in the new index and added sequential page numbers for the supplement pages to make them easier to locate for a specific brand.

I have cleaned up the specification pages that were published in the copy that I found. The text in the original copy was fuzzy and as such the text in this copy is not crisp which may make the search feature miss some part numbers.

This document represents many hours of work in recreating the information in a cleaner format - it is my hope that this document will assist Merc-O-Tronic owners when using this versatile ignition analyzing tool.

Even if the reader does not possess a Merc-O-Tronic unit a lot of the tests can be made using a modern multi-meter to help determine a defective ignition or charging component.



INDEX

Merc-O-Tronic Model 98 Information

Breaker Point Test	15
Coil - Power Test	5
Coil - High Speed Test	6
Coil - Surface Insulation Test	7
Coil - Continuity Test	8
Coil - Ground Test	9
Coil – Primary Resistance Test	8A
Coil - Testing Automotive Type	10
Coil - Testing With Two Secondaries	23
Condenser - Capacity Test	11
Condenser- Checking For Proper Grounding	16
Condenser – Leakage & Short Test	12
Condenser – Series Resistance Test	13
Continuity Test	19
Distributor Rotor Test	22
Index – original	132
High Tension Leakage – Crack Test	21
Operating Instructions	2
Resistance Test	19
Resistor Test	20
Rectifiers - Selenium Type Testing	24
Service Hints	43
Service Notes	1
Service Section For Evinrude – Johnson Uni-Charger or	
AC Generator / Alternator	27
Testing For Faulty Wiring	29
Testing Diodes	30
Testing Output of AC Generator or Uni-Charger	31
Testing Filed Windings	32
Testing The Stator Winding	33
Incorrect Regulator Voltage Setting	34
Adjusting Regulator Voltage Setting	35
Tailoring Regulator Voltage Setting	36
Internal Regulator Checks	37
Checking Field Discharge Diode	38
Checking Suppression Diode	39
Cleaning Regulator Contacts & Adjusting Air Gap	40
Spark Test	18
Starter - Armature Ground Test	17
Starter - Field Winding Ground Test	25

Starter - Ground Brush Test	25
Starter - Grounded Armature or Field Winding Test	26
Starter Solenoid Test	18
Timing - How To Time The Motor	16
Voltage and Coil Power Test Information	14
Manufacturers Specifications	41
AMC - "Saber"	45
American Bosch	51, 134, 153, 168
American Honda	156
Andover Corporation	134
Artic Cat	152, 168
Atlas – "Royal"	46
Auto Lite – Ford	47
Bendix Scintilla	48, 134
Bomdardier (Sk i Doo)	135
Bridgestone by Rockford Motors Inc.	57
Briggs & Stratton	56, 138, 153
British Seagull	57, 138
Bundy Marine	58
Canadian Curtis Wright	154
Chrysler (formerly West Bend Outboard Motors)	59
Chrysler Outboard Corp. 1966	64, 139, 169
Clinton Engine Corporation	67
Clinton Saw & Outboard Division	67
Commodore	68
Cushman Motors	69, 138
Delco – Remy	69, 138, 155, 169
Eaton Volvo	69
Echlin Condenser	70
Echo Chain Saw – see Kioritz	
Edison – Splitdorf	70
Eisemann	71
Elgin Outboard Motors – see Sears	110
Evinrude	86
Fairbanks - Morse	75
Fisher – Pierce	140
Ford – see Autolite	
Gale Products – Buccaneer	77, 140
Gamble – Hiawatha	82
German Bosch	54
Goodyear's – "Sea Bee"	83

Hirth	155
Homelite	84, 169
Honda	85
Husqvarna	170
Indian Motorcycle	170
International Harvester	85
J. I. Case Company	58
Jacobsen	140
John Deere Tractor Works	85
Johnson Motor	86
Jonsereds Chain Saw	157, 171
Kiekhaefer – Mercury Outboard	88, 140
Kioritz Corporation	171
Kohler Company	89, 141, 158, 173
Lauson Power Products	90
Lawn Boy	91
Mallory Electric Corporation	92, 143, 173
McCulloch Corp. Outboard Motor	93
McCulloch Chain Saws	104, 143, 159
Mercury Marine	159
Moto-Ski	157
O & R Engine	143, 160
Oliver Outboard	106
OMC- Evinrude & Johnson	86, 144, 160, 173
Onan Engine / Generator	105, 160, 174
Pioneer Chain Saw	109, 151
Pioneer GEN-E-MOTOR	109
Prestolite	47, 145, 175
R. E. Phelon	107, 145, 161, 174
Polaris	174
Robert Bosch	54, 147, 153
Robin	175
Rockwell Manufacturing Company – JLO Division	161
Rupp Industries	162
Sachs	162
Sears (formerly Elgin Outboard Motors)	110
Sears Craftsman Chain Saw – see Kioritz	
Ski Doo – see Bombardier	
Skiroule Ltd	162
Spiegel’s - “Brooklure”	117
Stihl Chain Saw	124, 163, 176
Tecumseh	148, 163, 176

Tilton Equipment	177
Triumph Motorcycle	163
Vertex Magneto manufactured by Ronco Corporation	109
Wards – “Sea King”	119
West Bend – see Chrysler	59
Western Auto Wizard Motors	123
Wico	125, 149
Wisconsin Motor Corporation	129
Yamaha International	164
1970 Supplement Bulletin	136
1971-72-3 Supplement Bulletin	150
1974-75 Supplement Bulletin	166

THIS SHEET APPLIES TO MODELS HAVING

SERIAL NO's, 15,000 AND UP

DESCRIPTION

PATENTED – OTHERS PENDING

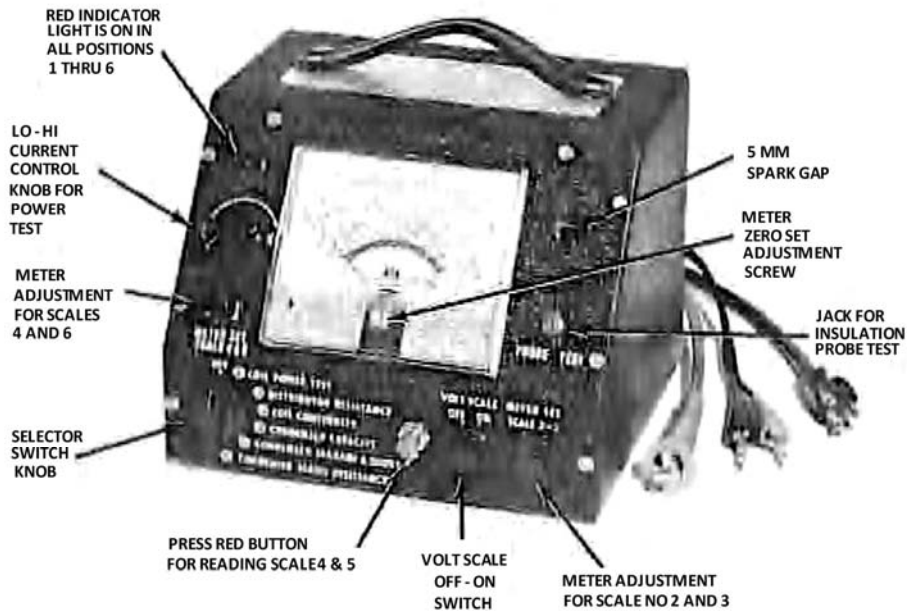

Figure 1

SERVICE NOTES

May we suggest, when testing, place Ignition Analyzer as well as Component Ignition Parts on an INSULATED OR WOODEN TABLE TOP. This will prevent any leakage or shock hazards.

Your Merc-O-Tronic Ignition Analyzer is equipped with either a motor or a vibrator. The motor has oil lite bearings and should be lubricated with a light oil once every six months. Lubricate cam wick at same time. (DO NOT OVER LUBRICATE.) If replacement of breaker points is required, order from Merc-O-Tronic Instruments Corporation as this is a special breaker assembly. Breaker points are to be set at 0.013". Pressure not to exceed 15 oz.

If vibrator fails to operate check and make sure that vibrator is in socket. When inserting vibrator, make certain pins line up with holes in socket.

NOTE: This is a special vibrator, if replacement is necessary order from your distributor or direct from factory. Merc-O-Tronic Part No. MIC # 12-191. (DO NOT ATTEMPT TO USE ANY STOCK VIBRATOR.)

Your analyzer is equipped with a Burgess 4F5H 7-1/2 volt battery. If unable to obtain locally, order direct from Merc-O-Tronic.

Be sure and specify type of battery required and serial number of unit.

OPERATING INSTRUCTIONS

For Model 98 Beginning with Serial No. 15,000

Before any attempt is made to use this instrument, read the following instructions. They were prepared to enable those having only a minimum of experience to test and repair the magneto ignition system equally as well as the electrical specialist. Adhere to the instructions in sequence. Do not jump from the first test to the fourth or the third to the fifth, etc.

1. Your Merc-O-Tronic Magneto Analyzer is shipped with a dry battery installed in the unit. Remove the 2 metal screws at the top of the panel. This will allow the top to swing back, and you will notice that the positive (red) battery lead is disconnected. Connect this lead to the positive (+) post of the battery. (When replacing battery, make certain positive terminal is to the right side of the tester and that the terminal nuts are tight.)
2. "Zero" meter by turning the small adjustment screw on front of meter until pointer hand lines up with zero on Scale No. 1, left side. This is set at the factory, but should be rechecked.
3. To determine the battery life do the following: Move switch for volt scale No. 1 to "ON" position. Attach small black test lead to negative and red small test lead to positive lugs on battery. Then place selector switch on No. 1 position. (Red pilot will be on and vibrator will be running). Read red figures on top of scale No. 1. Battery should check not less than 6.5 volts or proper readings cannot be obtained. (Each division on volt scale equals 0.5 volt).

For bench use this analyzer can be connected to an 8 volt storage battery power supply. For 8 volts tap off 4 cells from a 12 volt storage battery.

4. Your Merc-O-Tronic Magneto Analyzer is now ready for use.

The following batteries can be used in place of Burgess 4F5H:

Eveready 715	Olin 5605	Ray-O-Vac 903
Neda 903	RCA VS139	Mallory M903

To check low OHM resistance values see page 20.

See page 14 for Voltage Test Procedures.

CAUTION: DO NOT CONNECT TEST LEADS TOGETHER WHEN SELECTOR SWITCH IS TURNED TO POSITION NO. 1 AS THIS IS A DIRECT SHORT ON THE BATTERY.

FOR ALL TEST PROCEDURES INVOLVING SELECTOR SWITCHES 1 THRU 6 – VOLT SCALE SWITCH MUST BE IN "OFF" POSITION.

5. To check condenser leakage (on scale No. 5) and condenser capacity (on Scale No. 4), plug cord into 115-volt 60-cycle AC electrical outlet. This is the only time 115-volt 60-cycle AC is required. To read, press red button, the electrical charge placed in the condenser is automatically discharged when releasing the red button.
6. **SPECIAL NOTICE:** When checking Lauson Power Products Coils #30546, 30560 and 29632 or any coil with internal condenser the 5 m.m. pot spark will appear fuzzy. DO NOT let this fuzzy spark mislead you. If spark is steady, coil is good.

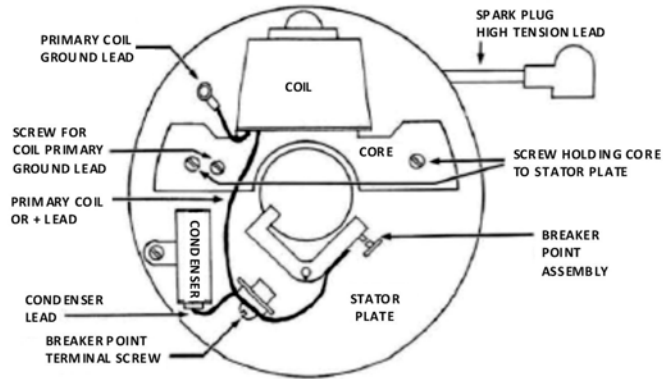

Figure 2

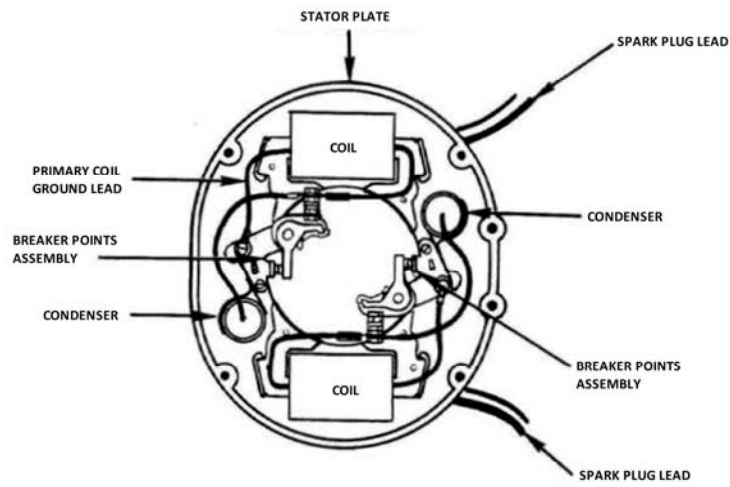

Figure 3

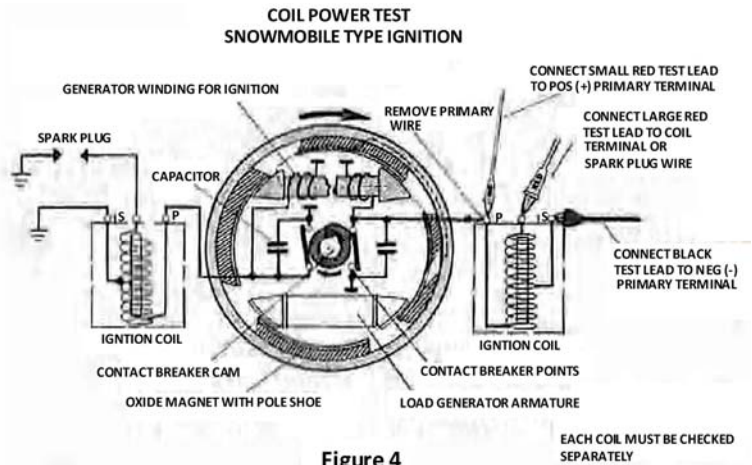

Figure 4

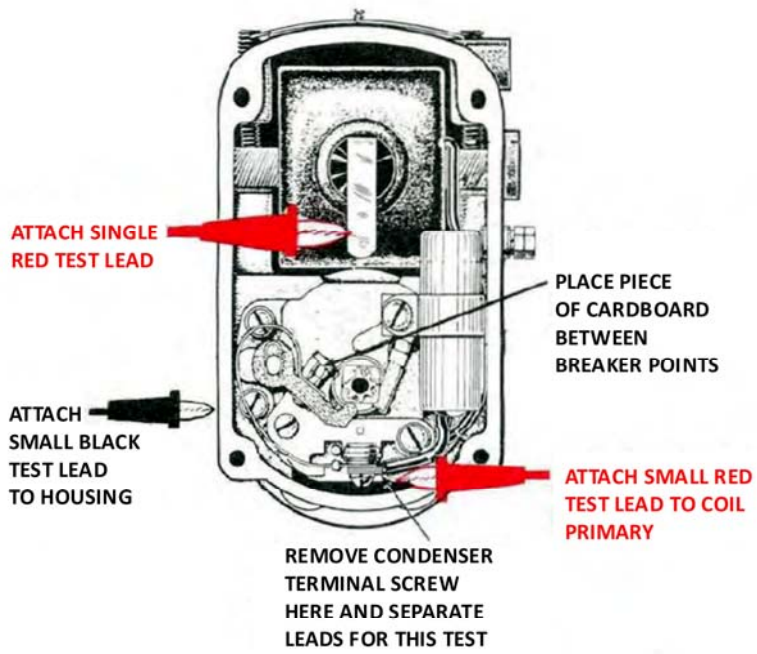

Figure 5

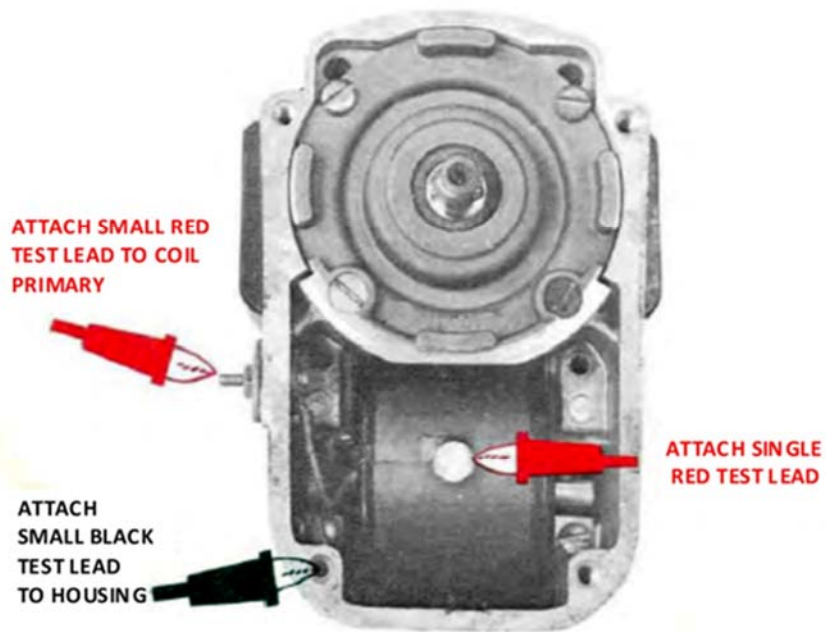
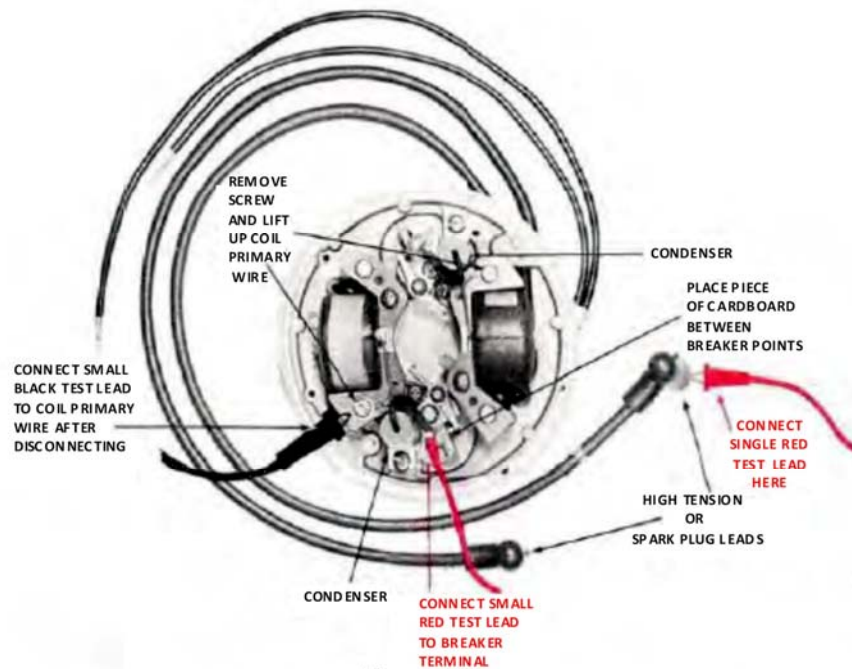

Figure 6

COIL POWER TEST



1. It is not necessary to remove magneto assembly from engine or parts from stator plate assembly.
2. Place a piece of cardboard between breaker points to insulate.
3. Connect small black test lead to coil primary ground wire.
4. Connect small red test lead to coil primary lead or breaker point assembly terminal.
5. Connect single red test lead to terminal of spark plug wire.
6. After wiring hookup is made, as shown in illustrations 6 or 7, the current control knob should be to extreme left, beyond "LO" position.
7. Turn selector switch to position No. 1 ("Coil Power Test").
8. Slowly turn current control knob clockwise and note the current value on Scale No. 1.
9. When it reaches the operating amperage for that particular winding, shown in this manual under Manufacturer's Specifications, stop and note the 5 MM spark gap, it should fire steadily.
10. If the spark is faint, intermittent or no spark has occurred at this reading, the coil is defective and must be replaced.
11. If a steady spark occurs below Manufacturer's Specifications, this indicates a very good coil.

COIL HIGH SPEED TEST

12. If the coil is good on Coil Power test, preceding, perform the High Speed Test.
13. Continue turning the current control knob clockwise to the right, for maximum reading of meter.
14. The spark gap should fire steadily.
15. If the spark is faint, intermittent or no spark occurs, the coil is defective at high speed and must be replaced.
16. Complete this test as quickly as possible and immediately upon completion, turn selector switch and power control to "OFF" position.

On Fairbanks-Morse and similar Magnetos, it is necessary to remove the distributor cap and end cap so **single red test lead** can be attached to secondary terminal of coil "see Fig. 5". **Small red test lead** is attached to coil primary lead after the lead has been removed from breaker point terminal. The small black test lead is attached to housing "see Fig. 5".

When checking coil on stator plate with crankshaft type high inductance rotating magnet (i.e. Wico, Scintilla and similar type magnetos), be sure rotating magnet is in **neutral position** (magnets not opposite the coil core).

NOTE: When testing coils off stator plate, it is absolutely necessary that the laminated core be in the coil.

NOTE: On Fairbanks-Morse and similar type magnetos, the coil primary lead must be removed from breaker point terminal during this test. This also applies to all coils which are permanently grounded to laminations. See Figure 5.

Coils with Two (2) Secondaries Testing, see Page 23.

Stator plate with 2 coils mounted, each coil to be checked separately as noted in Fig. 7.

NOTE: All coils should start firing 1 to 3 divisions before rated specifications. Coils which first start to fire on "rated" specifications are considered marginal and would give considerable trouble in starting engine and should be considered defective.

COIL SURFACE INSULATION TEST

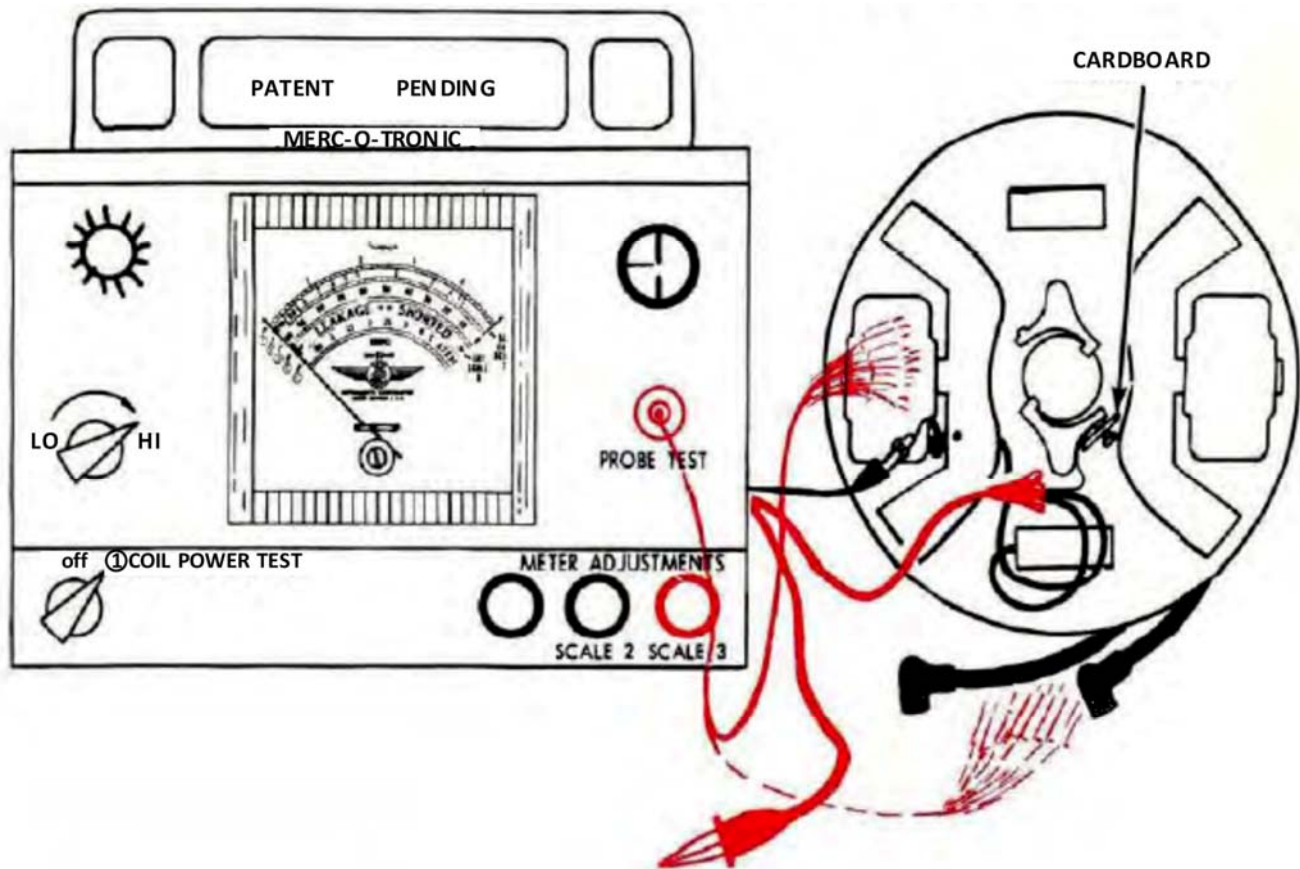

Figure 8

1. Remove single red test lead from coil secondary, (High Tension Lead) see illustration Fig. 8
2. **Small red and black test leads stay connected as previously.**
3. Plug insulation test probe into "JACK" on front of tester.
4. Turn selector switch to position No. 1.
5. Turn current control knob to "HI" position for maximum current reading on meter. **"Do not exceed meter reading."**
6. Pass end of insulation test probe over the insulating surface of the coil and spark plug wires.
7. If coil insulation is cracked, leaking or damaged, a spark discharge will be noted at the cracked or leaking surface.
8. **Do not permit test probe** to linger too long at any point while conducting this test.
9. **Complete test as rapidly as possible, as this is a severe test on a coil.**

A faint spark occurring around coil insulation during probing is a corona spark and does not illustrate a defective coil.

COIL CONTINUITY TEST

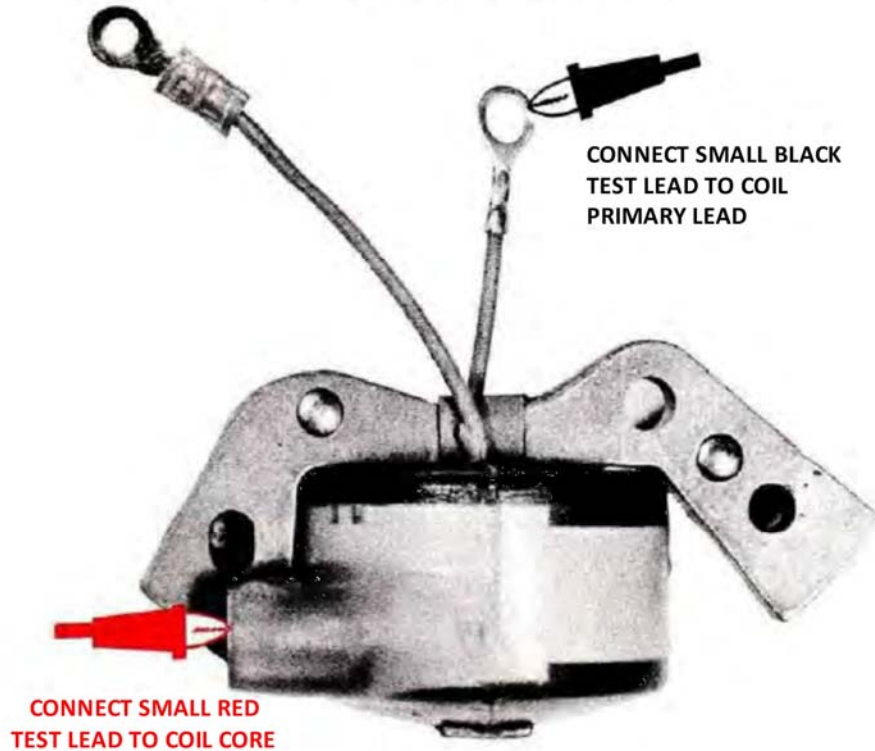

Figure 9

NOTE: Scale 3 has two scales. The upper number is the number shown on Mfg. specifications or are comparative numbers in place of actual ohm resistance "lower numbers." This is an added feature to our later model units starting with Serial No. 4050.

1. Turn selector switch to position No. 3 Coil Continuity.
2. **Clip small red and black test lead together.**
3. Turn meter adjustment knob for scale No. 3 until meter pointer lines up on set position on right side of scale No. 3.
4. Connect small black test lead to coil ground wire as in previous test.
5. **Connect small red test lead to spark plug "High Tension" lead.**
6. Reading must be between the two values for that particular coil shown in this manual under manufacturer's specifications.
7. Reading of actual resistance in ohms can be obtained by reading lower numbers in same scale.
8. Readings lower than the lowest value under manufacturer's specifications, the secondary winding is shorted.
9. Readings higher than the highest value shown in the specifications, the secondary winding is open.
10. In either case, the coil is defective and must be replaced.

PRIMARY RESISTANCE TEST

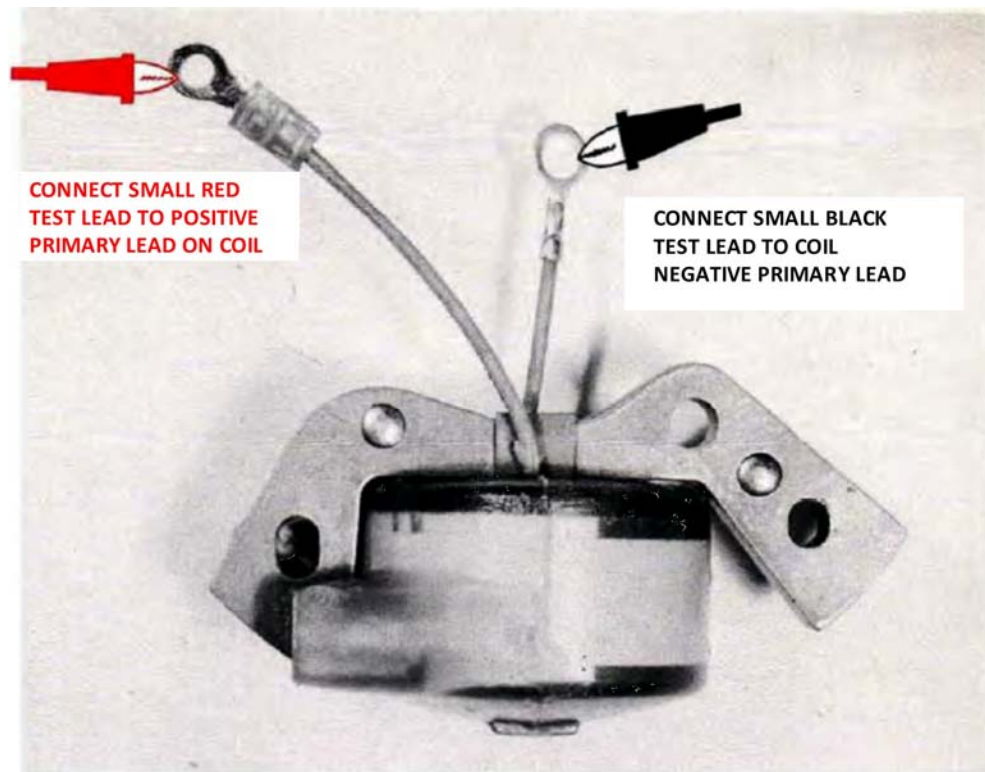

Figure 9A

1. Turn selector switch to position No. 2, Distributor Resistance for checking low **OHM** resistance values.
2. **Do not clip test leads together.** Turn meter adjustment knob for scale No. 2 until meter pointer lines up on set position on right side of scale No. 2. Your meter is now set to check all low OHM values from 0 to 30 ohms.
3. **Clip small red test lead** to primary **Positive** side of coil.
4. Connect small black test lead to primary Negative side of coil.
5. Read **Red** figures on Scale No. 2.
6. Reading must be between the two values for that particular coil shown in this manual under manufacturer's specifications.
7. Resistance in OHMS can be obtained by reading **Red** numbers in same scale.
8. Readings lower than the highest value shown in the specifications, indicate the primary winding is shorted.
9. Readings higher than the lowest value under manufacturer's specifications, indicates the primary winding is open.
10. In either case, the coil is defective and must be replaced.

COIL GROUND TEST

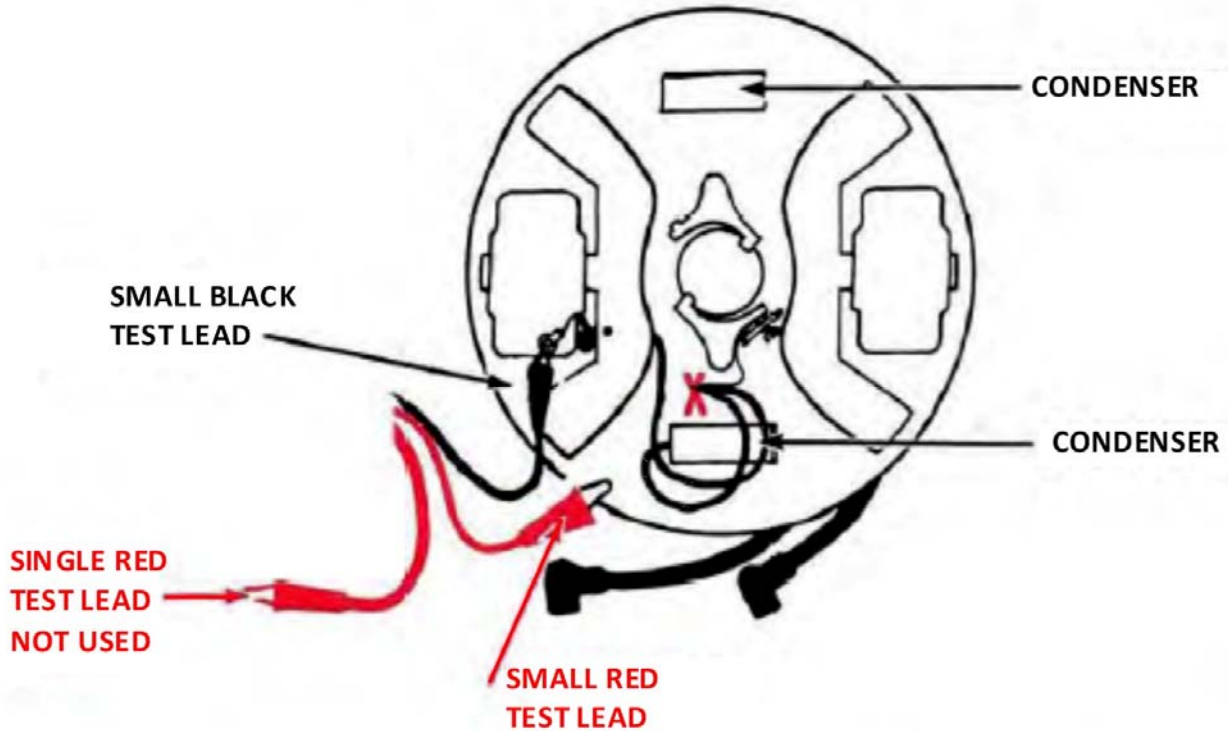

Figure 10

1. Leave small black test lead connected as in Coil Continuity Test
2. Remove small red test lead from high tension wire and connect it to ground or frame of stator plate. (See wiring hookup, Fig. 10.)
3. Turn selector switch to position No. 3 and read Scale No. 3.
4. The meter pointer hand must be on the "ZERO" line at the left side of the meter.
5. Any meter movement to the right indicates a grounded coil.
6. If there is a meter pointer hand movement to the right, indicating a grounded coil, remove the breaker point screw at "X" on diagram Fig. 10.
7. Remove primary coil wire at this point. If the meter needle remains to the right the trouble is elsewhere.
8. Check condenser for short or grounded breaker points.

NOTE: When coils are permanently grounded to laminations (i.e. Fairbanks-Morse, Bendix-Scintilla), see illustrations and similar type Fig. 11, it is not possible to check for ground. This type of coil must indicate a ground (movement of meter pointer hand to full right).

NOTE: When coils are not permanently grounded to lamination, it is possible to check for ground. This type of coil must not indicate any movement of meter pointer hand.

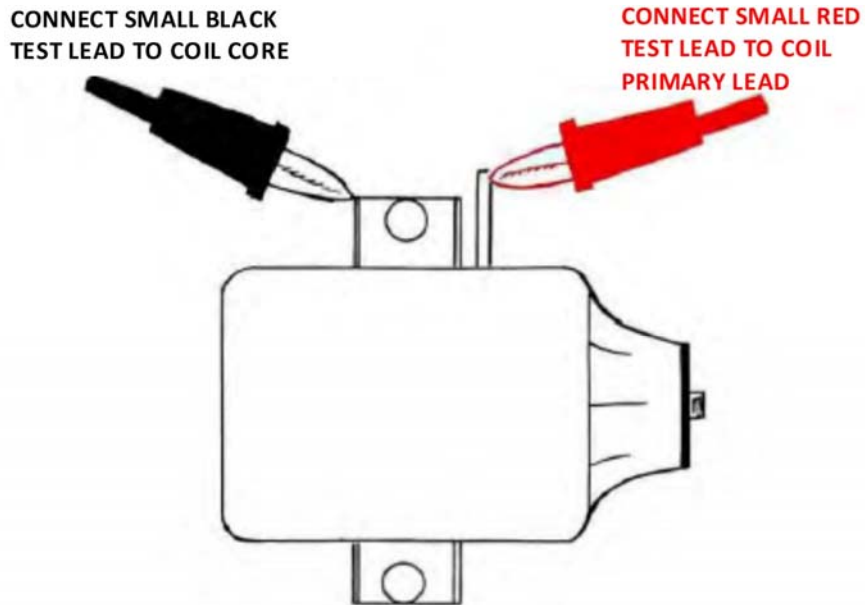

Figure 11

AUTOMOTIVE TYPE COILS

To test automotive type coils, place small red test lead to positive (+) terminal of coil and small black test lead to ground (-) terminal of coil. Place single red test lead into secondary high tension (plug in terminal) of coil. Follow procedure for testing coils on Pages 5 and 6 and refer to illustration Fig. 13 showing insulation test on automotive coil.

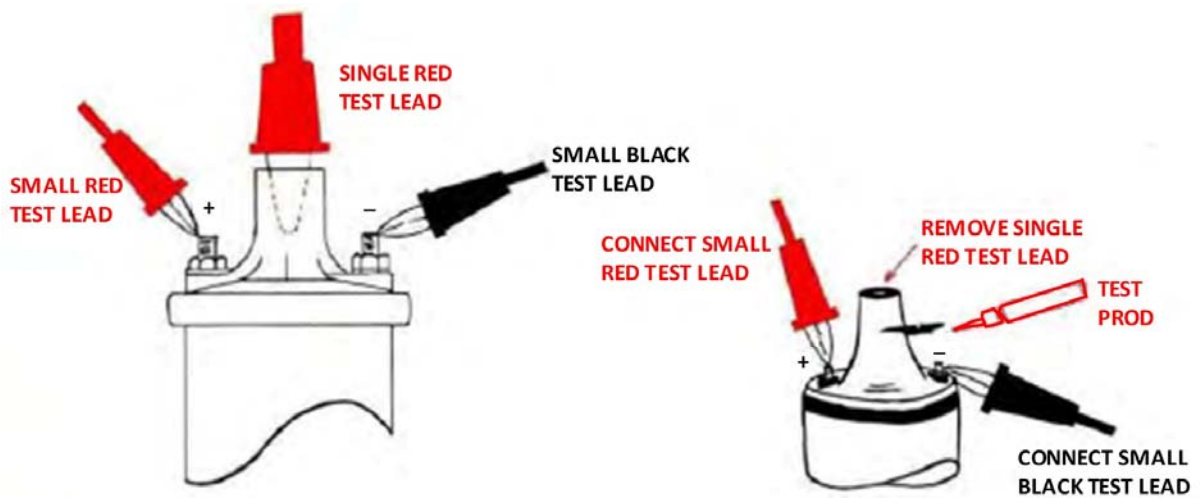

Figure 12

Figure 13

CONDENSER CAPACITY TEST

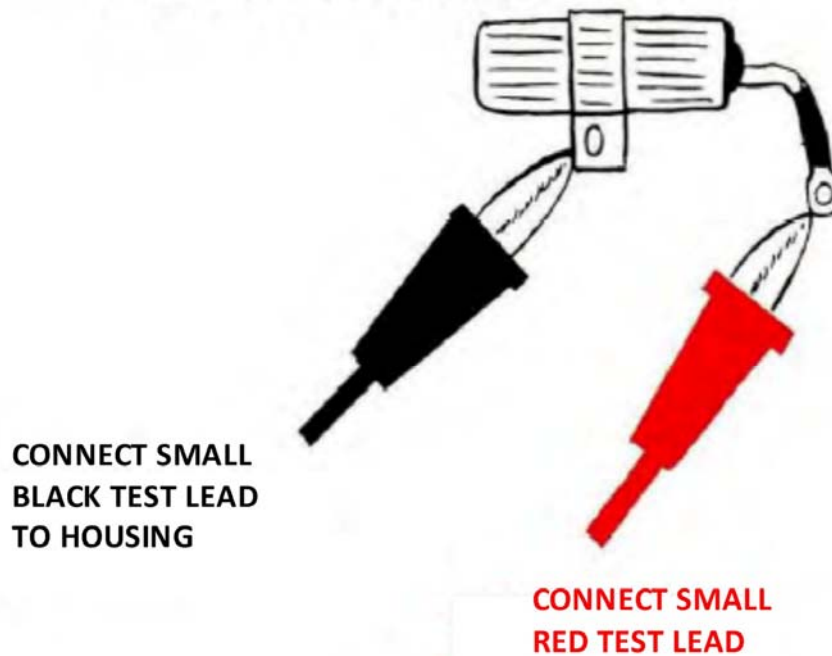

Figure 14

1. To make condenser test, cord must be plugged into 115 volt 60-cycle AC outlet.
2. Leave cardboard between breaker points.
3. Place selector switch on position No. 4, Condenser Capacity.
4. Clip small red and black test leads together.
5. Depress red button, turn meter adjustment knob on scale 4 to set line on scale No. 4 on right side of meter. (This adjustment is for varying line voltages throughout the country.)
6. Unclip test leads.
7. Connect small red test lead to breaker terminal or if loose to condenser lead.
8. Connect small black test lead to stator plate if condenser is mounted, otherwise to body of condenser. (Depress red button to read Scale 4.)
9. Condenser must be within manufacturer's specification for this particular motor.
10. If not, replace as a condenser that is over or under capacity could cause burnt breaker points.

CONDENSER LEAKAGE AND SHORT TEST

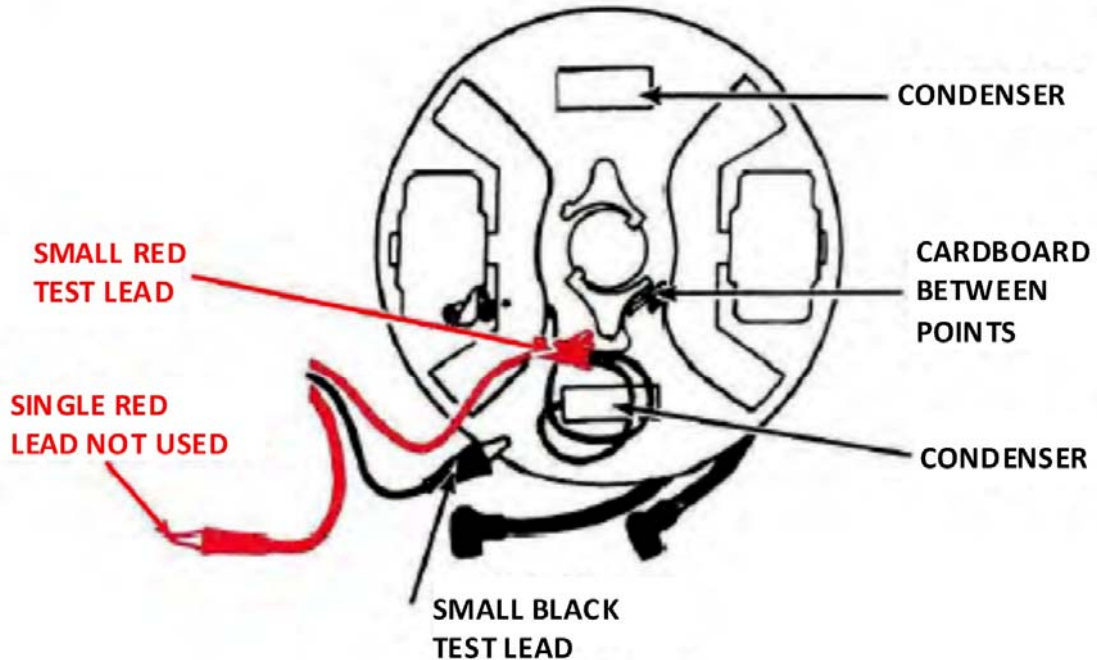

Figure 15

1. Connect small black test lead to stator plate if condenser is mounted, otherwise to body of condenser.
2. Connect small red test lead to breaker terminal, or if unmounted, to condenser lead.
3. Leave cardboard between breaker points.
4. To make condenser test, cord must be plugged into 115 volt 60-cycle AC outlet.
5. After wiring hookup is made, turn selector switch to No. 5 "Leakage and Short."
6. Depress red button and hold a minimum of 15 seconds. Read Scale No. 5.
7. The meter pointer hand will move to the right and must return within range of the narrow black bar at the left.
8. Any readings to the right of the black bar indicate the condenser is leaking or shorted and must be replaced.

NOTE: On Fairbanks-Morse type magnetos or equal, the condenser lead must be removed from the breaker point terminal when testing on a complete magneto. Condenser should be taped against an insulated board while testing to show up loose element.

**CONDENSER SERIES RESISTANCE TEST
FOR MODEL 98 USE ONLY**

1. Leave cardboard between breaker points.
2. Place selector switch on position No. 6 "Condenser Series Resistance".
3. Clip **small red** and black test lead together.
4. Adjust meter set scale 6 to set line on right side of dial for scale No. 6.
5. Unclip test leads.
6. **Connect small red test lead to breaker terminal or if loose to condenser lead.**
7. Connect small black test lead to stator plate if condenser is mounted, otherwise to body of condenser.
8. Meter pointer must be within ok green block on scale No. 6 on right side of meter.
9. **While testing "move" and "wiggle" the lead coming out of the condenser.**
10. Observe meter pointer for any movement.
11. **Loose connections** can cause trouble if the condenser is subjected to a great deal of vibration.
12. If meter pointer remains within ok green bar on scale No. 6 the condenser is good.
13. If meter pointer moves into the **red section** on Scale 6 or if by **wiggling the condenser lead it moves into the red section**, then the condenser is defective.
14. This test usually helps to determine the ability of the condenser to readily charge and discharge.

NOTE: This test is very sensitive, as the latest techniques are being used for this test.

DUE TO THE SENSITIVITY OF THIS TEST, MAKE CERTAIN TEST CLIPS AND PARTS THAT TEST CLIPS ARE ATTACHED TO ARE CLEAN OR FALSE READINGS WILL BE OBTAINED.

VOLTAGE AND COIL POWER TEST INFORMATION

Use the two small leads (Red and Black) for checking voltage readings from 0 – 24 volts maximum. Small red lead is positive and black lead is negative.

Scale No. 1 is actually two scales in one. The red scale is for checking voltage. Each red line or division represents 1/2 volt with a maximum reading of 24 volts. Do not attempt to check voltage if selector switch is on any other position than "OFF" except when checking battery in analyzer. Voltage can only be checked when volts Scale No. 1 switch is in the "ON" position.

THE BLACK SCALE IS FOR CHECKING AMPERAGE DURING THE COIL POWER TEST ONLY. Each black division on the scale represents 1/10 of an amp, with the black 1 representing 1 amp etc. up to maximum of 4 amperes. Amperage during coil power test can only be read when The Volts Scale No. 1 switch is in the "OFF" position.

NOTE

When voltage switch is in the "ON" position, analyzer is inoperative on all other tests. Be sure to place volt switch in "OFF" position for other tests on analyzer. Do not attempt to use volt scale for ammeter readings.

BREAKER POINT TEST

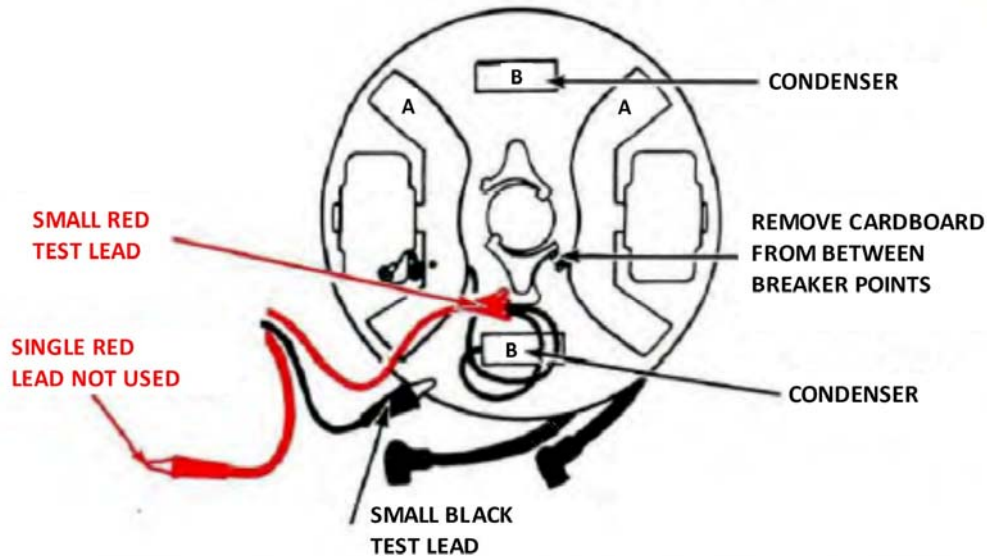

Figure 16

TESTING FOR HIGH RESISTANCE IN PRIMARY CIRCUIT

1. Turn selector switch to position No. 2 "Distributor Resistance".
2. Clip small red and black leads together.
3. Turn meter adjustment knob for scale No. 2 until meter pointer lines up with set position on left side of "OK" block on scale No. 2.
4. Unclip small red and black test leads.
5. Connect small red test lead to breaker point terminal.
6. Connect small black test lead to stator plate or any part of engine per illustration No. 16.
7. Turn crankshaft until cam allows breaker points to close.
8. The meter pointer must return in the "OK" block.
9. If the meter pointer is in the high resistance band, this indicates that there is foreign matter between breaker points.
10. See note.
11. Breaker assemblies not meeting this test should be replaced.

NOTE: Although breaker points are made of non-corrosive metal a current resisting tough film may form after the engine stands for a period of time, especially if stored in a damp place. This film will cause hard starting of the engine. By running a piece of stiff paper (such as a business card) between the points under tension several times, the film will wear and dirt or oil will be removed from between the breaker points. After cleaning points in the above manner, the meter should be in the "OK" block. If not, replace breaker points.

TO CHECK CONDENSER FOR PROPER GROUNDING

1. Connect small black test lead to stator plate
2. Connect small red test lead to body of condenser. Point B see illustration Fig. 16
3. Read Scale No. 2.
4. The meter pointer must be in the "OK" band.
5. If meter pointer reads in the high resistance band this indicates that the condenser is not properly grounded to the plate.
6. Check points in the same manner.

TIMING

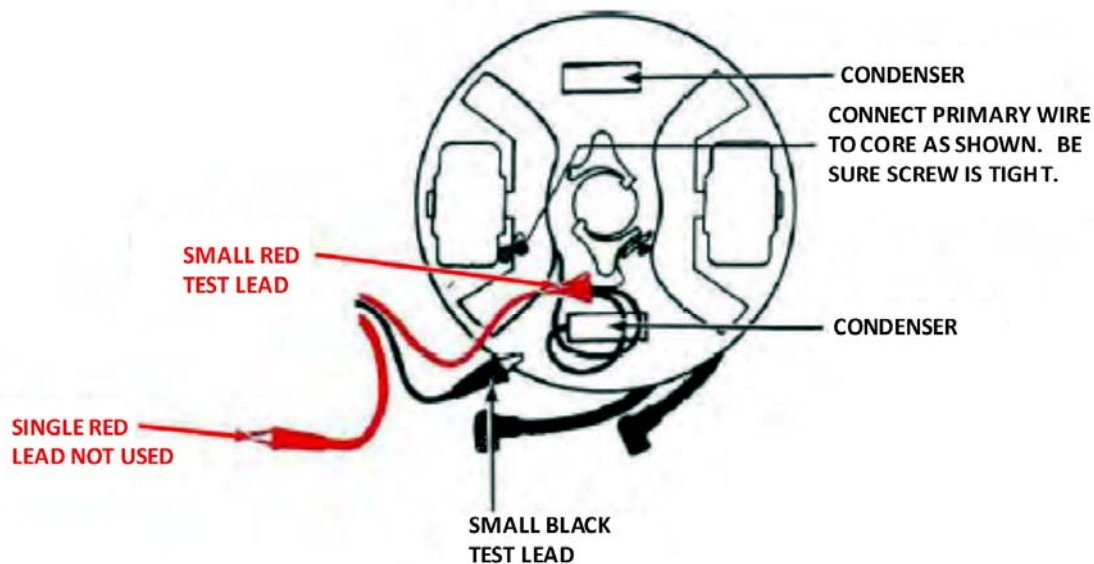

Figure 17

BEFORE TIMING

Preliminary to timing motor, set the breaker points to the manufacturer's specifications. Use a **feeler gauge – don't guess**. Be sure the breaker rubbing block is on the highest part of the cam when setting points. (Refer to "Breaker Point Test", preceding.) Lubricate the cam oiler wick of the breaker arm with fibre grease (as specified by manufacturers). Be sure the moveable arm is free on pin and lubricate pivot pin with fibre grease. Be sure all screws are tight and that all wires are in their proper place.

TIMING

1. Remove paper from between breaker points and clean points before test. **DO NOT FILE.**
2. Connect small black test lead to the stator plate frame.
3. Connect small red lead to the breaker point terminal screw.

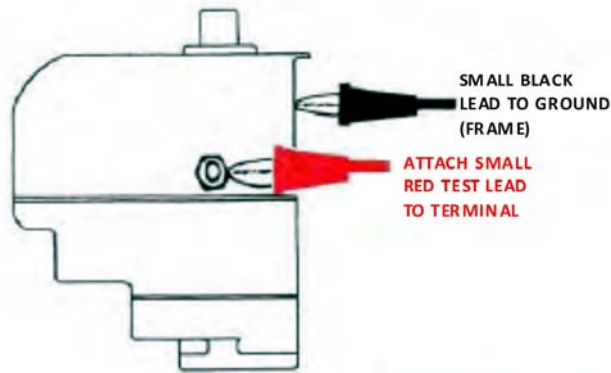

Figure 18

“See your manufacturer’s service manual for the particular motor specification relative to piston movement with timing of magneto.” Set this first.

Again, be certain that the breaker points are making perfect contact. Refer to “High Resistance Test in Primary Circuit”, preceding. After wiring hookup is made, as shown in illustration preceding, turn selector switch to position No. 2, “Distributor Resistance”, and read **Scale No. 2**. Rotate magneto or distributor in the advance direction. It will be noted, when points are closed, that the meter pointer hand will be in the “OK” block. The moment that the breaker points start to open, the meter pointer hand will move into the high resistance band. In this manner, the timing can be set in relation to movement of the piston.

On magnetos, such as Fairbanks-Morse or Kiekhaefer type, connect the small red test lead to the exposed primary ground terminal and the black lead to the frame or ground. See Fig. 18.

ARMATURE GROUND TEST

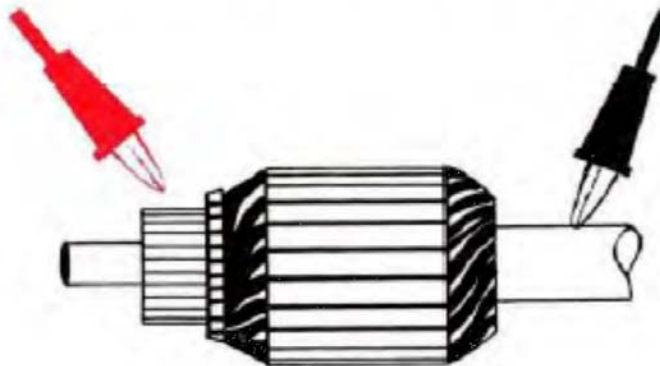

Figure 19

Turn selector switch to position **No. 3, “Coil Continuity”**. Attach small black test lead to armature shaft, as shown in illustration above, and use small red test lead to probe the commutator copper divisions. If the pointer hand moves across the meter to the right, as the divisions are contacted, the armature is grounded and must be replaced or commutator must be cut down and mica must be undercut. Meter pointer hand should not move during this test.

SPARK TEST



Figure 20

With the selector switch in “OFF” position, disconnect the high tension lead from the spark plug and clip **single red test lead to spark plug lead**. Place test probe into red jack and attach opposite end to cylinder block to form ground. Crank engine over and view spark jump through tester’s small window. If no spark, indications are that some part of the magneto is defective or lead wire is broken. Repeat process for each spark plug lead wire.

NOTE: IF SELECTOR SWITCH IS IN ANY OTHER POSITION, DAMAGE TO THE METER WILL RESULT.

STARTER SOLENOID TEST

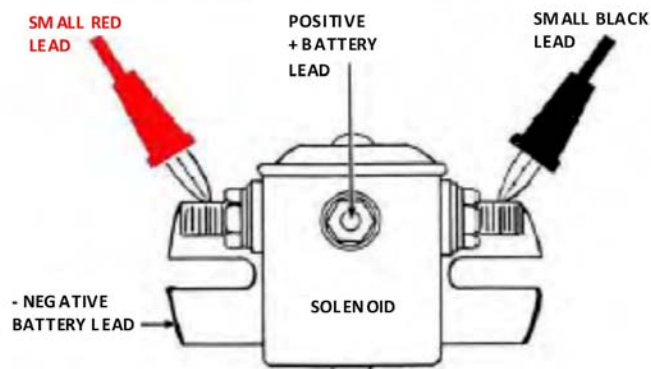

Figure 21

1. Turn selector switch to position No. 3, “Coil Continuity”.
 2. **Connect small red test lead to one large terminal of solenoid**, as shown in illustration above.
 3. Connect small black test lead to other large terminal of solenoid.
 4. With a battery of the capacity of the solenoid (6 or 12 volts), place two jumper leads on battery terminals.
 5. **Connect positive lead to small terminal of solenoid.**
 6. Connect negative lead to case or bracket of solenoid for ground.
- NOTE: On solenoids with two small terminals, one is usually a ground terminal and one an **energized terminal**.
7. Meter pointer hand must move fully to right of meter.
 8. If no movement or only partial movement is indicated, the solenoid is defective and must be replaced.

CAUTION: DO NOT CONNECT BATTERY LEADS TO LARGE TERMINALS OF SOLENOID OR METER WILL BE DAMAGED.

CONTINUITY TEST



Figure 22

To test ignition or electrical wires and harness or parts for “open circuits”, turn selector switch to position No. 3, “Coil Continuity” and Zero out meter. Connect small black test lead to one end of wire and **small red test lead** to opposite end of same wire, as shown in illustration above. Meter pointer hand must move fully to the right of the meter. If the meter pointer hand stays at left, this indicates a broken wire. Move lead wire back and forth while making test.

RESISTANCE TEST

To check an electrical harness and wire terminal to determine if the part is OK, place selector switch on Scale No. 2, “Distributor Resistance”. Attach **small red test lead** to terminal of one end of lead and small black lead to other end. Meter pointer needle must return to “OK” block. If needle favours right side **away from “OK” band** it indicates a defective connection inducing a resistance. Repair connection or replace part.

RESISTOR TEST

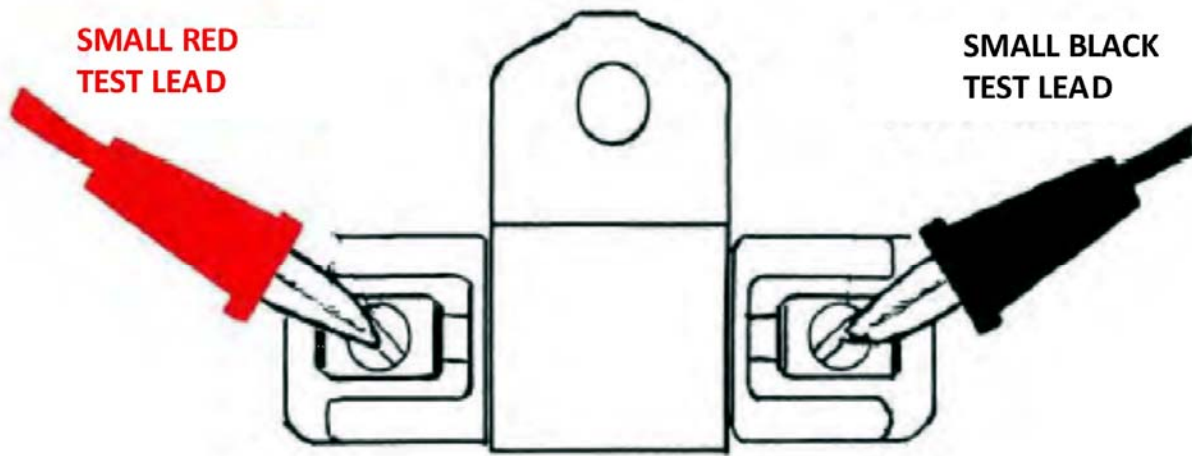
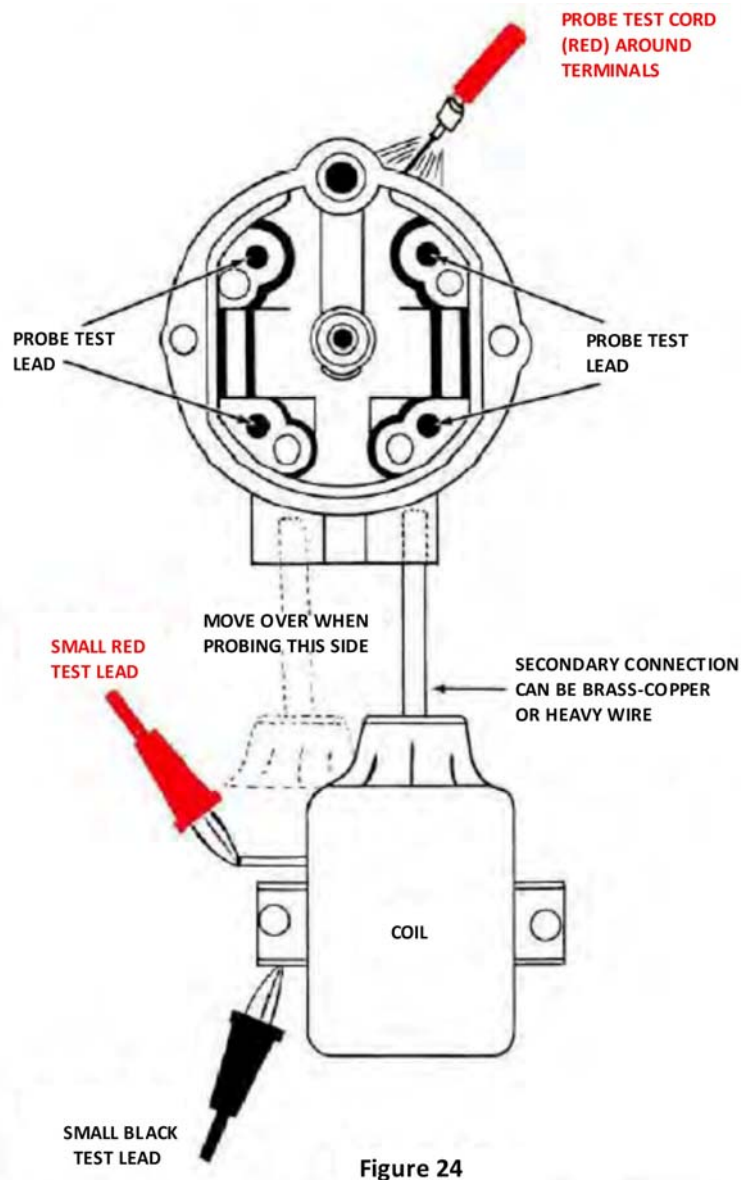

Figure 23

Use **scale No. 2** for checking **low OHM** resistance values. Set selector switch on No. 2, “Distributor Resistance”, position. **Do not clip test leads together.** Turn No. 2 scale meter adjustment knob to adjust meter needle with **red line on right side of Scale No. 2.** Your meter is now set to check all low OHM values from 0 to 30 OHMS. **Clip small red and black test leads** to terminals of resistor, as shown in illustration above, and read red figures on **Scale No. 2.** Replace resistor not meeting the manufacturer’s specifications.

Manufacturer	Part No.	Resistance Reading	
		Min	Max
Keikhaefer Mercury	393-1286	1.3	1.7
Keikhaefer Mercury	393-1482	2.0	2.4
Keikhaefer Mercury	393-1572	3.0	3.4
McCulloch (Scott)	332-196	1.7	1.9

HIGH TENSION LEAKAGE - CRACK TEST



To check for cracks or leakage paths in ignition distributor caps or distributor rotors, clip small red test lead to coil primary lead and black test lead to coil core, as shown in illustration above. A used coil is best for this test, since the coil will be used for inducing a high secondary voltage. The secondary coil terminal must have a brass or copper lead attached so that it will extend fully into the distributor cap spark plug lead wire outlet to provide the spark for this test. Turn selector switch to position No. 1, "Coil Power Test", and turn "LO-HI" current control knob to the "HI" position. Place test probe into jack in tester and pass other end of test probe over area around distributor contact post. If there is a crack or leakage path, it will show up by the spark following a path in the cap rather than sparking directly to the correct terminal. If the spark path occurs, the cap is defective and must be replaced. There should be no spark jump to any other distributor post other than the one being tested. Repeat procedure on each post of distributor cap.

DISTRIBUTOR ROTOR TEST

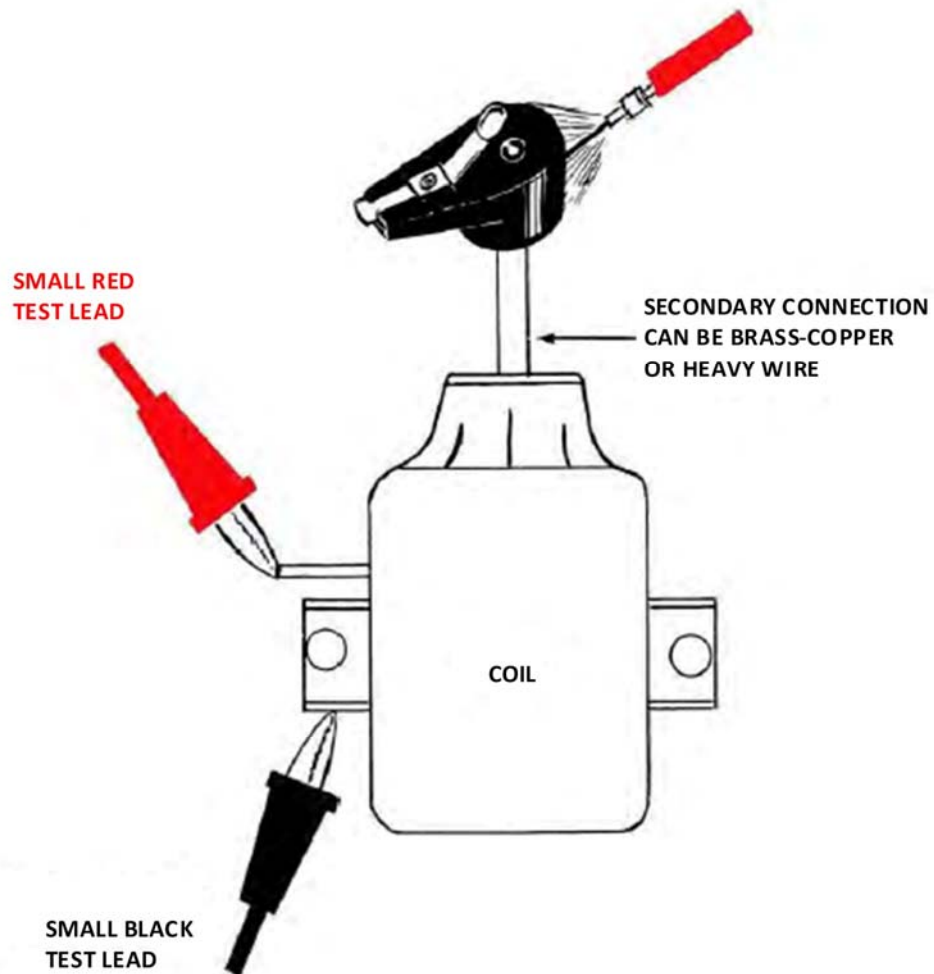

Figure 25

Follow distributor cap leakage test procedure, preceding. Place distributor rotor on high tension terminal of coil so that rotor shaft hole rests on coil terminal as shown in Figure 25. Search around distributor rotor with ground test probe. There should be no spark jump at any point. If a heavy spark does occur, it indicates a defective distributor rotor. Replace defective part.

TESTING COILS WITH TWO SECONDARIES

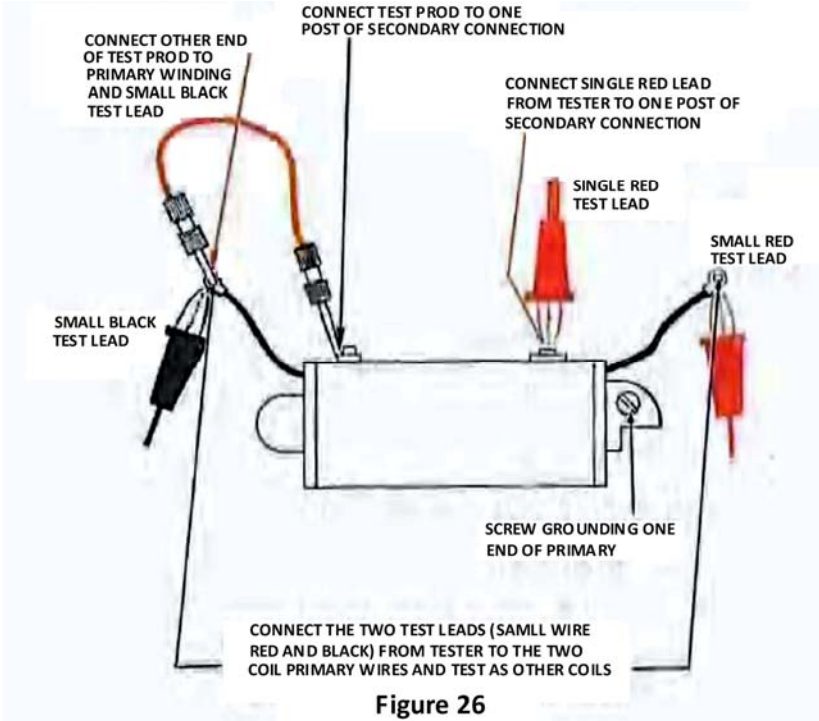

Figure 26

TESTING CONVENTIONAL TYPE MAGNETO

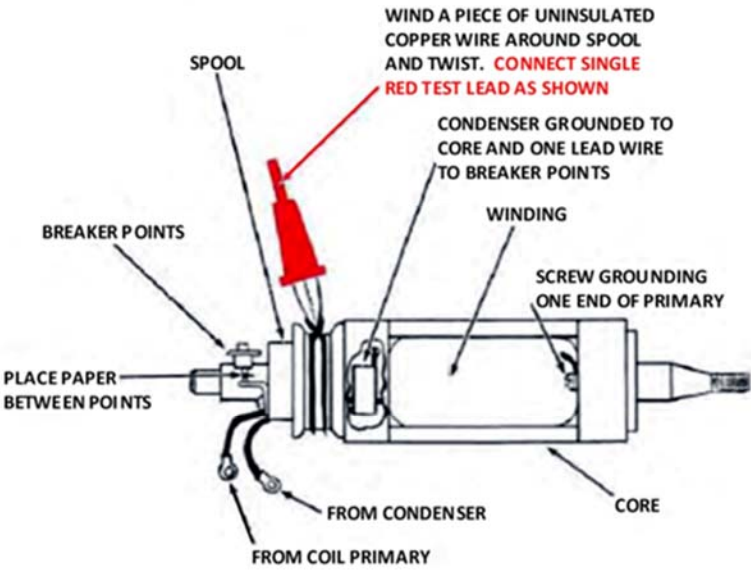

Figure 27



Figure 28



Figure 29

TESTING SELENIUM RECTIFIERS

BY MEASURING DIRECT CURRENT RESISTANCE

1. Set selector switch on position No. 3, "Continuity".
2. Clip **small red** and black test leads together and turn meter adjustment knob for Scale No. 3 until meter pointer lines up on set position on Scale No. 3, right side.
3. **Connect small red test lead to positive lead on rectifiers. Figure 28.**
4. Connect small black test lead to ground stud or lead on rectifier. Figure 28.
5. Note reading of figures on **lower band, Scale No. 3.**
6. Reverse test leads on rectifier and note readings again.
7. **Ratio of two readings should be 10:1 or greater.**
8. Remove analyzer test leads and connect to the two alternator leads or lead terminals on rectifier. Figure 29.
9. Note reading on figures on **lower band, Scale No. 3.**
10. Reverse test leads on rectifier and note readings again.
11. **The ratio of the two readings should be no more than 2:1.**
12. This is only a **preliminary** test to determine condition of rectifier. If questionable, as a final test, rectifier should be installed on engine and checked with ammeter while engine is running.

NOTE: This is a true ohm scale, 0 – 200,000 ohms and can be used to test ohm resistance of other electrical components.

FIELD WINDING GROUND TEST



STARTER MOTOR DISASSEMBLED

1. Turn selector switch to position No. 3, "Coil Continuity".
2. Attach small red test lead to insulated terminal on outside of starter motor and small black test lead to starter motor frame.
3. Meter hand should not move. If it does it indicates the field is grounded.
4. On starter motors having two fields 1) forward winding 2) reverse windings, test both insulated terminals.

GROUND BRUSH TEST



STARTER MOTOR DISASSEMBLED

1. Turn selector switch to No. 3, "Coil Continuity".
2. Attach small black test lead to the grounded brush and small red test lead to frame to which brush is fastened. (End cap housing or field frame.)
3. Meter hand must move to the right, if not, there is a poor ground connection.
 - a) replace the ground brush and lead or
 - b) check that the lead connection is secure to the frame.
4. There is also a possibility of the brush holder having a poor ground to the frame or end cap, test by following steps 1, 2, 3 above.

GROUNDING ARMATURE OR FIELD WINDING



STARTER MOTOR ASSEMBLED

1. Raise ground brushes from commutator and insulate them from commutator with cardboard. Make sure brush is not touching commutator.
2. Turn selector switch to position No. 3, "Coil Continuity".
3. Attach small red test lead to insulated terminal on outside of starter motor and small black test lead to starter motor frame.
4. On starter motors having two fields 1) forward winding 2) reverse windings, test both insulated terminals. While making test move brush lead, making sure there is a solid connection.
5. **If analyzer shows continuity (meter hand moves to the right) there is a ground, check individually (a) and (b) below:**
 - a) Check armature - Page 17 Armature Ground Test.
 - b) Check Field Winding separately – Page 25 Field Winding Ground Test.

SERVICE SECTION

FOR

EVINRUDE – JOHNSON

UNI-CHARGER

OR

**AC GENERATOR
- ALTERNATOR**

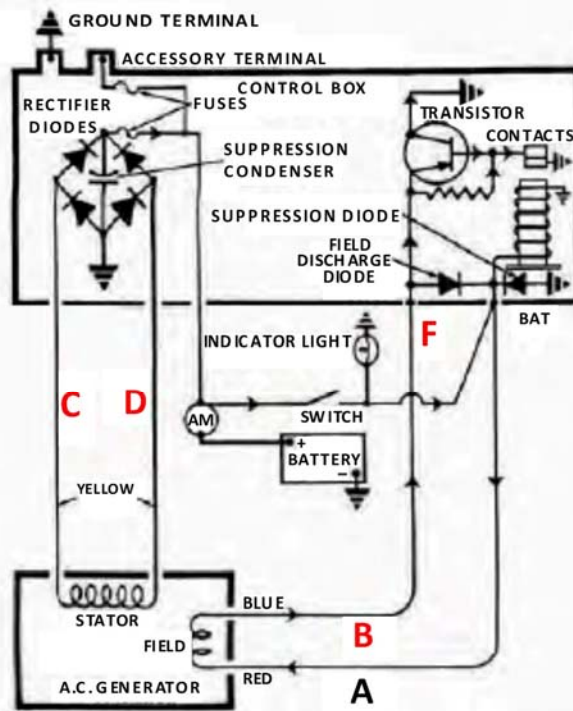

Figure 30

TESTING FOR FAULTY WIRING

1. A short between two wires, or a grounded wire, or high resistance connections can cause the charging circuit to operate improperly.
 - A. If the lead from the field winding to the "F" terminal of the regulator (marked "B" in the wiring diagram Fig. 30) should become grounded. Battery will be charged excessively.
 - B. If a high resistance should develop at the "BAT" terminals and the wires connected to the "BAT" terminal at regulator. Ammeter will show an excessively high rate of charge, causing battery to use an abnormal amount of water.
 - C. A short circuit between leads from the stator winding to the rectifier (wires marked "C" and "D", Fig. 30) or from these becoming ungrounded. Ammeter will show a discharge and an undercharged battery would result.
2. It is important that wiring be checked visually for damage due to corrosion, frayed insulation and loose connections.
3. Additional checks are covered in the following sections.

TESTING FOR SHORTED OR OPEN RECTIFIER DIODES, OR

A SHORTED SUPPRESSION CONDENSER (CAPACITOR)

1. Before checking diodes for shorts or opens, disconnect battery leads, the large nylon connector, the condenser lead, the four diode leads from the harness and remove both fuses.
2. To check the condenser for capacity and shorts, refer to pages 11 and 12, Fig. 14. Also top of page 16 for proper grounding.
3. Condenser capacity is approximately .2 microfarads.

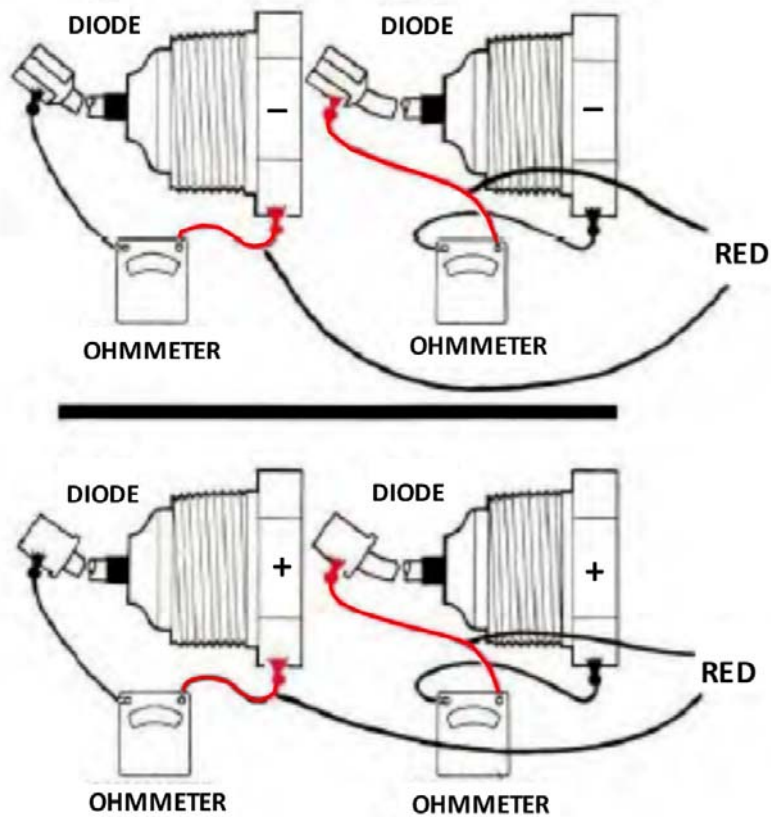

Figure 31

TESTING DIODES

1. To test diodes for shorts and opens, **each diode must be checked twice.**
2. These two checks are accomplished by reversing **the polarity such as the negative and positive.**
3. This test can be made on your Merc-O-Tronic Analyzer. (Black lead-, **small Red lead-**)
4. By placing selector switch on position No. 3 Coil Continuity (See page 8, paragraph 1, 2, and 3) and by reading the lower red figure on meter scale No. 3.
5. Connect small test leads as shown in Fig. 31 between the center post and the base.
6. A zero reading in both test leads as outlined above indicates the diode is shorted.
7. A normal diode will show a **high reading in one direction and a low reading in the opposite direction.**
8. An infinite (**Very High**) reading in both tests indicates the diode being tested is open.
9. Before replacing a diode, **coat the diode threads with silicone grease** or light engine oil, and then tighten to 150 – 180 inch-pounds of torque.

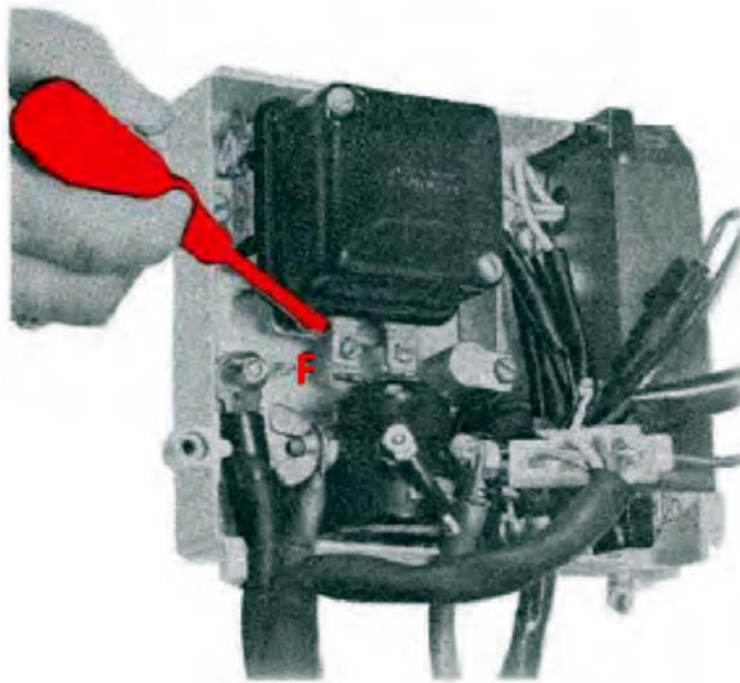

Figure 32

TESTING OUTPUT OF AC GENERATOR OR UNI-CHARGER

1. The AC generator can be checked for output by shorting between the regulator “F” terminal and ground with a screwdriver. (Fig. 32).
 - A. Operate engine slightly above idle speed, (1500 RPM) and note the reading on the ammeter.
 - B. All accessories must be turned off when this check is made.
 - C. If output is increased (note ammeter reading) the AC generator, uni-charger or rectifier is not at fault
 - D. The trouble is probably due to an improper regulator voltage setting or a defective regulator.
 - E. In this case, proceed to the section entitled “Checking Regulator Voltage Setting”.
2. If no output is obtained, the AC generator or uni-charger is defective.
3. Both the field winding and the stator winding should be checked with the ohmmeter on the Merc-O-Tronic Analyzer scale No. 2 or 3 as required.

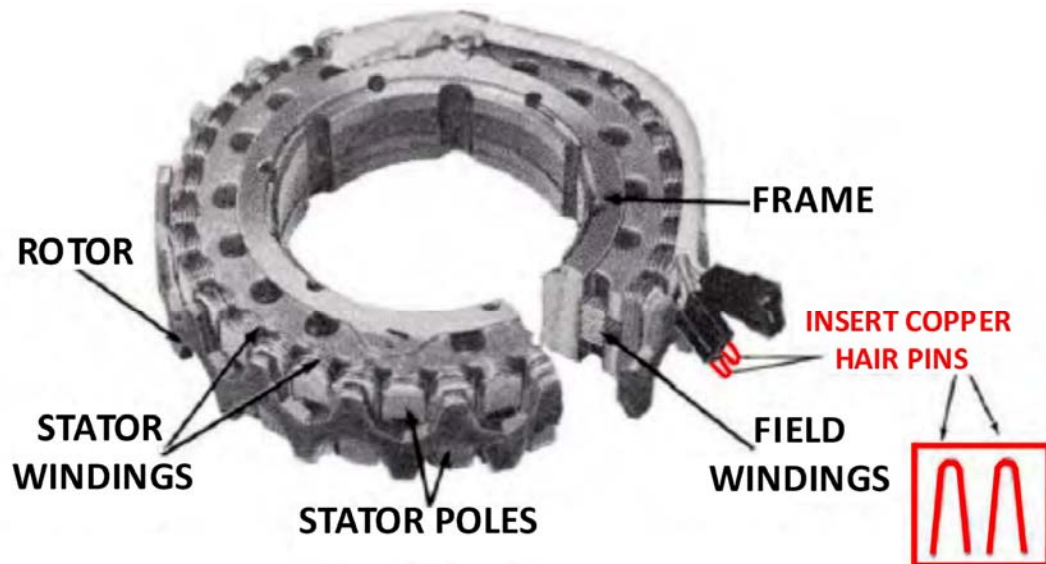

Figure 33

TESTING FIELD WINDINGS

1. To test the field winding, separate the field winding connector (the one with the red and blue leads) from the wiring harness.
2. Take two pieces of bare copper wire (20 GA) about 2" long and shape into hair pins. See illustration above.
3. Place in each female connector making contact with each terminal, see Fig. 33.
4. This will allow you to make field winding test without any difficulty.
 - A. Turn selector switch to position No. 2 - do not clip small test leads together.
 - B. Adjust meter knob scale No. 2 so meter pointer will line up on red set line on right side of meter.
5. After zeroing in meter pointer attach one small test lead to either hairpin connector and the other small lead to the lamination or stator.
6. The reading should be infinite if the field winding is not grounded.
7. When testing for shorted or open field windings leave the two copper hairpins in position as in Fig. 33.
8. Connect the other small test lead to the hairpin and leave selector switch on Position No. 2, read scale No. 2.
9. The reading should be 1.2 – 3.2 ohms or (1.9 – 2.2 ohms at 80°F.)
10. A lower reading indicates a shorted winding.
11. An infinite reading indicates winding is open.
12. In either case the field winding is defective.

TESTING THE STATOR WINDING

1. Adjust analyzer for the following tests procedure.
 - A. Place selector switch on position No. 2.
 - B. Adjust meter, knob for scale No. 2 until meter pointer lines up on **set position on right side of Scale No. 2.**
2. Separate the Stator Winding Connector (**the one with the two yellow leads**) from the harness.
3. Take one small test lead and **attach to one of the copper contacts in the harness connector.**
4. The other small test lead attach to the **core.**
5. Read meter scale No. 2, reading should be **infinite.**
6. Any meter pointer movement indicates the winding is **partially grounded.**
7. If meter pointer moves to the left, this indicates the winding is **grounded or defective.**
8. If meter pointer does not move at all remove small test lead connected to the core and **attach to the other copper contact in the harness connector.**
9. Leave selector switch on **position No. 2.**
10. **Read meter scale No. 2** (which is the low resistance value scale).
11. Winding should show a reading of **minimum .2 – maximum .3.**
12. If meter pointer moves only a part of the way, **this indicates a poor connection or a partial open.**
13. If meter pointer does not move at all or there is an infinite reading **this indicates winding is open.**
14. In either case the winding is defective and stator assembly should be replaced, or defect located and repaired.
15. **Internally shorted stator windings** are difficult to test due to the very low resistance of the windings.
16. If all the generator and rectifier checks are satisfactory but the output is low, **an internally shorted stator winding** (which in some cases do not show up on the meter) **could be the cause.**

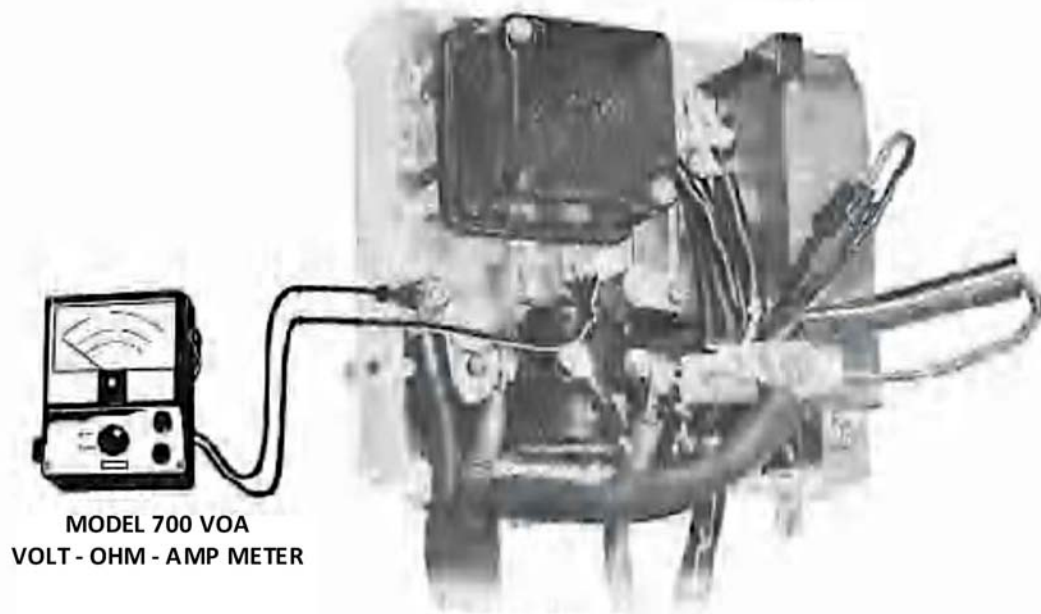

Figure 35

INCORRECT REGULATOR VOLTAGE SETTING

CAUTION: Do not short across any of the terminals in the junction box.

1. To check the voltage setting reconnect all connections and then connect the positive Merc-O-Tronic Model 700 VOA voltmeter lead to the regulator "BAT" terminal and the negative lead to ground. (Fig. 35).
2. Turn on the switch but do not start the engine.
3. **The Model 700 VOA voltmeter reads battery voltage.**
4. **A zero reading indicates** an open in the circuit between the regulator and the battery. If green "on light" lights up on the dash the open circuit would be between the **key switch and regulator**. If ignition coil had current the open would be from the **red wire to the field to regulator**.
5. Operate the engine at **1500 rpm for 20 minutes** with the **cover on the regulator and all accessories turned off** to bring the regulator to operating temperature.
For accurate RPM readings use the Merc-O-Tronic Electronic Service Tachometer.
6. Turn off the ignition switch to stop the engine.
7. Restart the engine, operate at 1500 rpm and note the voltage setting.
8. The dash ammeter must show a charge of not over **10 amperes at the time the voltage setting is read**.

A fully charged battery must be used to adjust regulator.

9. If the voltage setting is 15 volts or above, the charge rate may continue above 10 amperes after the 20-minute warm-up period.
10. In this case the voltage setting needs to be reduced.
11. If the voltage setting is below 15 volts but the charge rate remains above 10 amperes, continue to charge the battery until the **charge rate drops below 10 amperes before reading the voltage setting.**
12. The voltage setting should be **14.4 to 15.0 volts at ambient temperature.** Ambient temperature is the temperature of the air surrounding the regulator 1/4 inch from the cover.

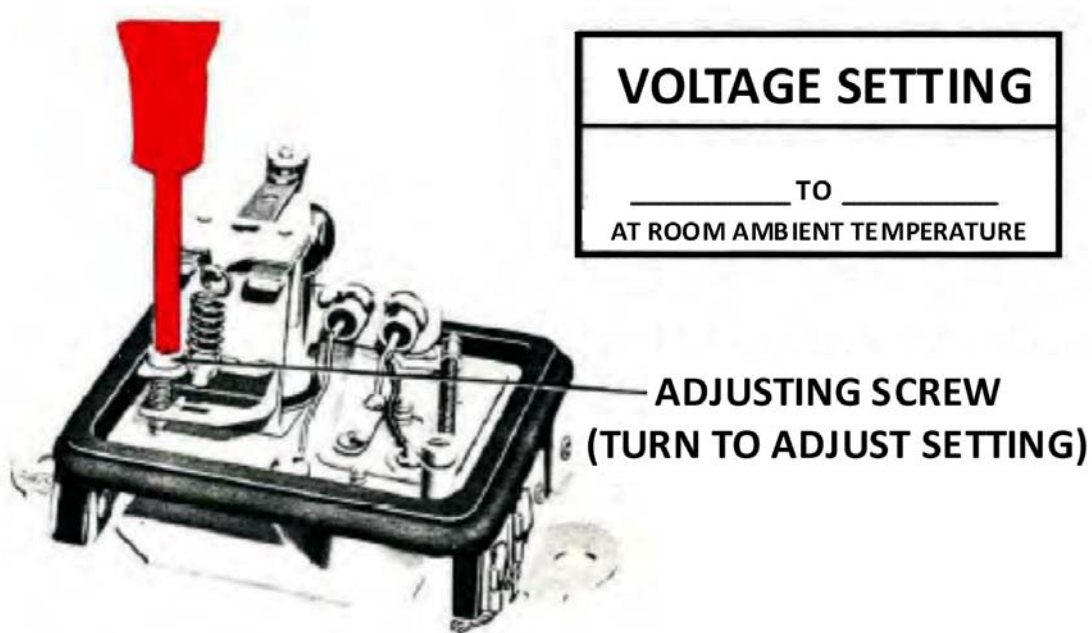

Figure 36

ADJUSTING VOLTAGE SETTING

1. To adjust the voltage setting, remove the regulator cover and turn the voltage adjusting screw located on the back of the voltage unit. (Fig. 36).
2. This should be done after the 20-minute warm-up period with the engine operating at 1500 rpm.
3. Turning the screw clockwise will raise the setting, and counter-clockwise will lower the setting.

CAUTION: Always make final setting by turning the screw **clockwise**. This insures that the springholder will be against the head of the screw. Therefore, turn the screw **counterclockwise farther than necessary** to make the adjustment. Then turn the screw clockwise to make final setting. **Replace the regulator cover.**

4. After making the setting, turn off the switch and stop the engine.
5. Restart the engine and operate it at 1500 rpm and note voltage setting.
6. Readjust if necessary.
7. **Always stop and restart the engine before reading the final voltage setting.**
8. Always make final voltage checks with the **regulator cover in place.**
9. If the setting cannot be adjusted to the desired value, **the regulator is defective internally.**

TAILORING REGULATOR VOLTAGE SETTING

1. **Unusual operating conditions** may make it necessary to “tailor” the voltage setting to avoid battery overcharge or undercharge.
2. If the engine is operated consistently at low speeds with accessories turned on, the battery may become discharged even though the units in the charging circuit are functioning satisfactorily.
3. Raising the voltage setting to a value within the specified limits may correct the condition.
4. **If increasing the setting does not correct the trouble, it is likely that the accessory load is too great for the generator output at that particular speed.**
5. Similarly, consistent operation at moderate or high speeds with light electrical loads may result in excessive battery water usage denoting battery overcharge.
6. This is especially true under hot weather conditions.
7. A lower voltage setting in this case may be required.
8. **If changing the setting by .3 volt does not correct the condition,** the setting should be changed an additional .3 volt and then a check made for an improved battery condition.

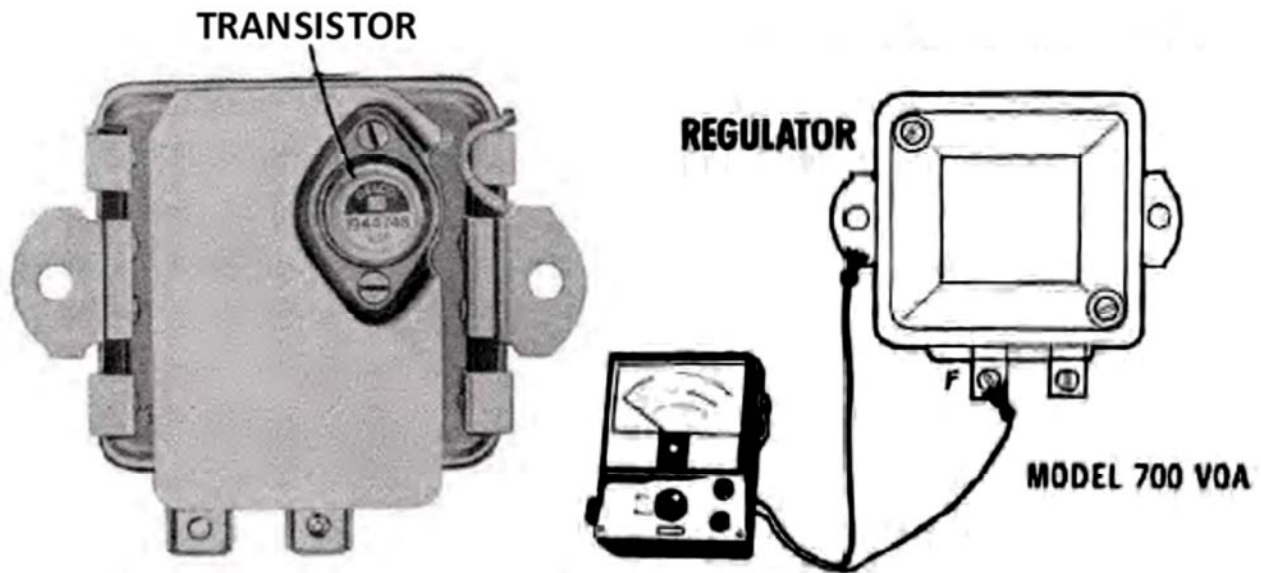

Figure 37

INTERNAL REGULATOR CHECKS

The components inside the regulator may be checked with the regulator connected in the circuit as shown in Figure 30.

TRANSISTOR

1. To check the transistor, connect the Model 700 VOA voltmeter from the regulator "F" terminal to ground (Fig. 37).
2. Close the switch without starting the engine, and note the Model 700 VOA voltmeter reading.
3. A reading of approximately 1 to 2 volts is normal.
4. If the reading is zero volts, the transistor is shorted.
5. An intermittent short between the leads from the field winding to the regulator (marked "A" and "B" on the wiring diagram, Fig. 30), an open regulator field discharge diode, an open suppression diode, or excessive heat can cause the transistor to become shorted.
6. If the reading is approximately 8 to 9 volts the transistor is burned open.
7. An open transistor can result from a direct short between the field winding leads ("A" and "B" in the wiring diagram, Fig. 30), or from interchanging the leads at the regulator "F" and "BAT" terminals.

8. If the reading is battery voltage, both the transistor and regulator resistor are burned open.
9. The transistor and resistor, if damaged, must be replaced before proceeding with the remaining checks.
10. To replace the resistor, merely unsolder the connections.
11. To replace the transistor, disconnect battery and all regulator leads and remove regulator from junction box. Then remove the two transistor attaching screws and unsolder the two transistor connections inside the regulator box.

NOTE: Do not reconnect the regulator leads until after the field discharge diode and suppression diode have been checked.

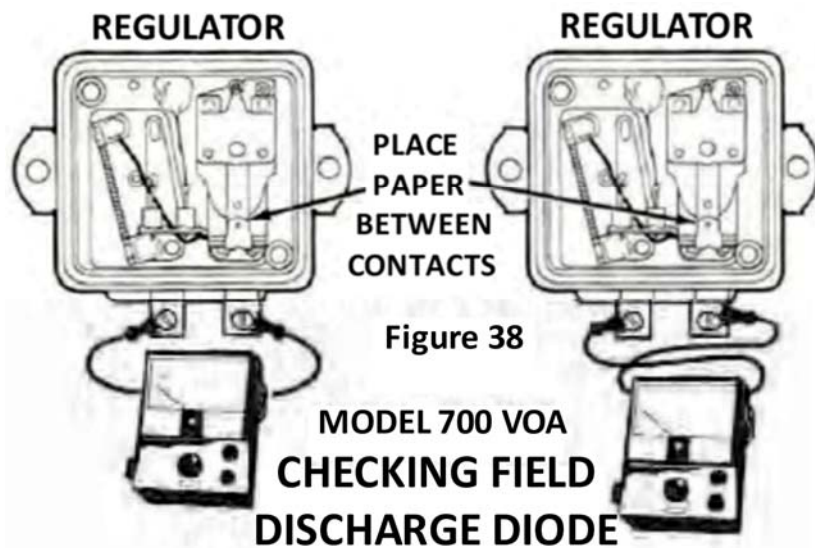

FIELD DISCHARGE DIODE

The following tests can be made on Merc-O-Tronic analyzer selector switch position No. 3 Meter Scale No. 3.

1. To check the field discharge diode, place a small piece of clean white paper between the voltage contacts to insulate them. See Fig. 38.
2. Connect small leads from analyzer to the "F" and "BAT" (Fig. 38) terminals. (Note the readings).
3. Reverse the lead connections to the "F" and "BAT" (Fig. 38) terminals. (Note the readings).
4. If either reading is very high (infinite), the regulator field discharge diode is open.
5. If both readings are approximately zero, the regulator field discharge diode is shorted.
6. Remove the small piece of paper.
7. To replace the diode, merely unsolder the connections.

CAUTION: Excessive heat will damage diode.

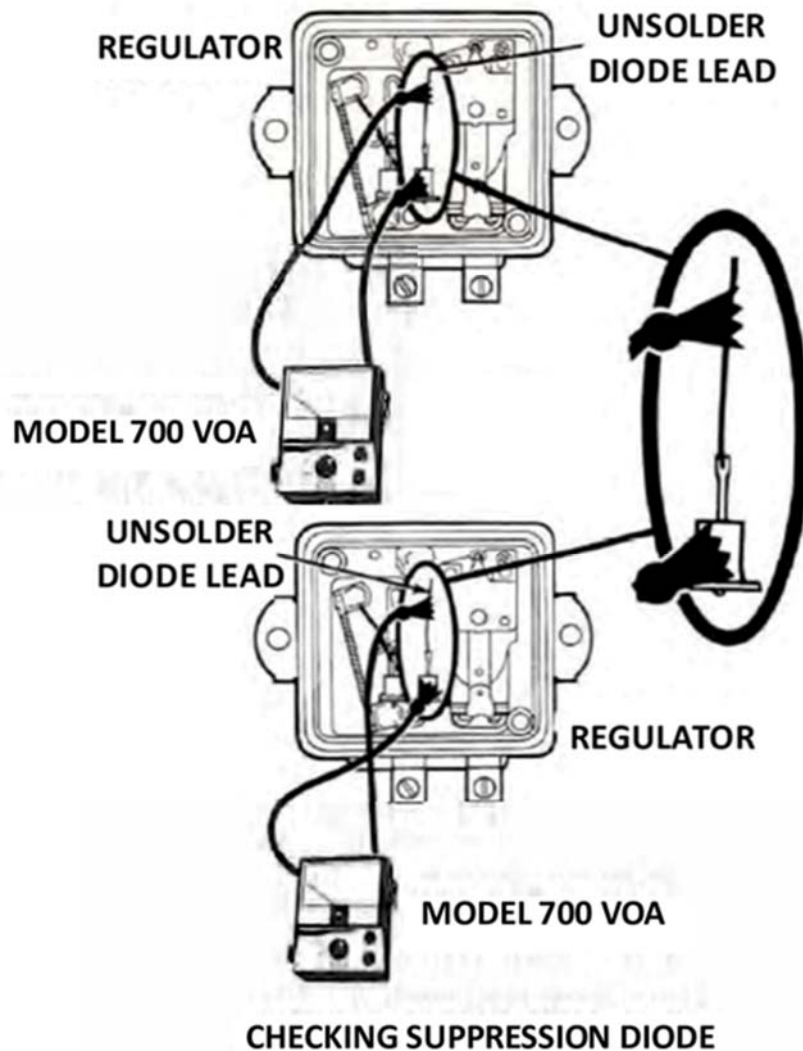
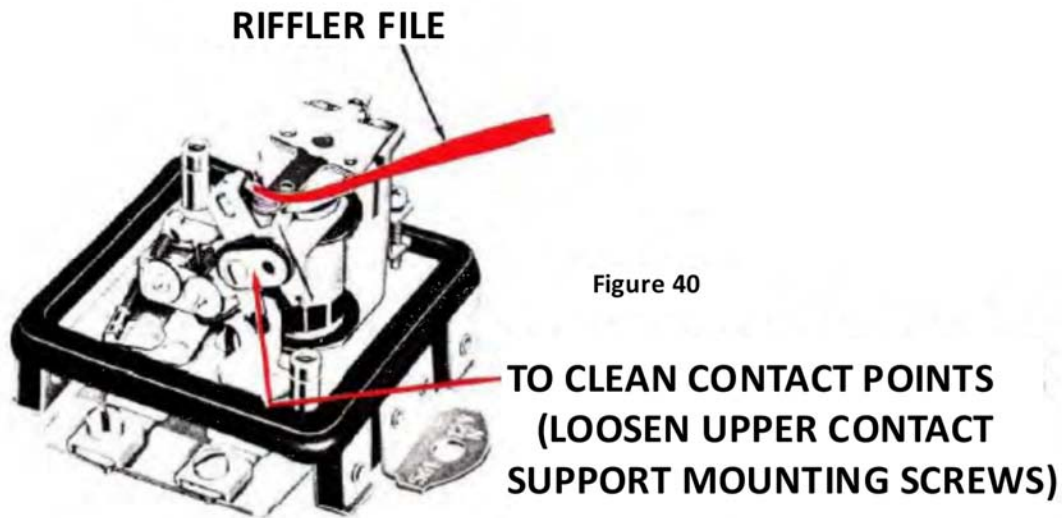

Figure 39

SUPPRESSION DIODE

1. To check the suppression diode, unsolder its lead from the regulator base and connect the small leads from analyzer from the diode lead to the diode case (Fig. 39). Use Test Position No. 3.
2. Then turn polarity reversing switch on Model 700 VOA.
3. **If both readings are very high (infinite), the diode is open.**
4. If both readings are **zero**, the diode is shorted.
5. To replace the diode, merely unsolder the connections.

CAUTION: Excessive heat will damage diode.



CLEANING CONTACTS

1. If an open transistor was found in the previous check, the large voltage regulator contact must be cleaned with a **spoon or riffer file as illustrated in Figure 40.**
2. The small soft-alloy contact does not oxidize and must be **cleaned with crocus cloth or other fine abrasive material.**
3. Contacts should be washed with **trichloroethylene or some other non-toxic cleaning solution to remove any foreign material.**
4. After cleaning contacts run a piece of stiff paper (such as a business card) between contact under **tension**, thereby removing any **film or foreign matter.**

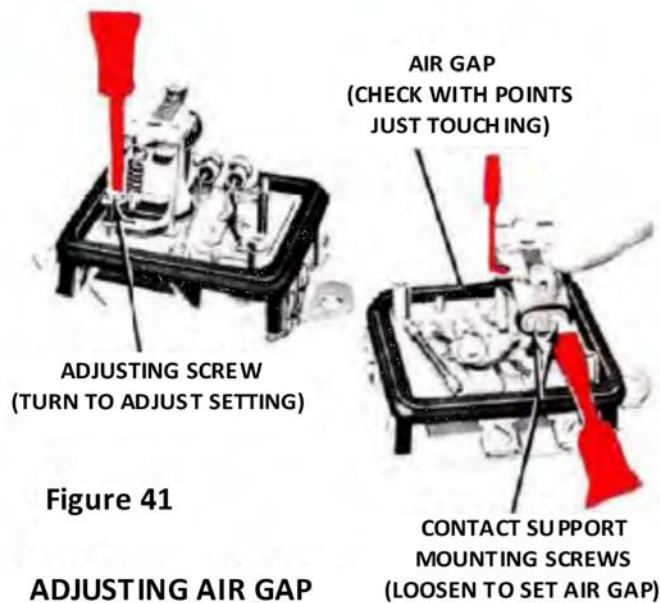

1. After cleaning the contacts, set the air gap to **.070 inch** as shown in Figure 41.
2. Push the armature (**not the flat spring**) down against a gauge.
3. Adjust the upper contact support so the contacts are **aligned squarely and just touch when the support screws are tightened.**

**MANUFACTURER'S SPECIFICATIONS
FOR COIL AND CONDENSER
TESTS ON MERC-O-TRONIC
IGNITION ANALYZER.**

**TESTS MADE MUST
BE WITHIN THE SPECIFIED
TOLERANCES OR THE PART
SHOULD BE REPLACED AS IT
IS DEFECTIVE AND NOT UP
TO MANUFACTURER'S
SPECIFICATIONS.**

**ALL REFERENCES TO USE A 12-VOLT STORAGE
BATTERY APPLY TO THE USE OF A MODEL 88, 98
OR 98A ANALYZER ONLY.**

SERVICE HINTS

Ignition Failures

I. Engine Misfires at Idle or High Speed, Presuming Carburetion and Fuel are OK, Check For:

- Incorrect spark plug gap
- Defective or loose spark plugs
- Spark plugs of incorrect heat range
- Spark plug gap set incorrectly
- Sticking or weak breaker arm spring
- Incorrect breaker point gap
- Breaker points not synchronized
- Breaker points not properly adjusted
- Loose wire in primary circuit
- Defective distributor rotor
- Corroded or pitted breaker points
- Cracked distributor cap
- Leaking or broken high tension wires
- Weak armature magnets
- Worn cam lobes on distributor or magneto shaft
- Worn distributor or magneto shaft bushings
- Defective coil or condenser
- Defective ignition switch
- Spark timing out-of-adjustment

II. Engine Backfires Through Exhaust, Check For:

- Cracked spark plug porcelain
- Carbon path in distributor cap
- Crossed spark plug wires
- Air leak at intake deflector
- Improper timing

III. Engine Pre-Ignition, Check for Ignition Causes:

- Spark advanced too far
- Incorrect type spark plugs
- Burned spark plug electrodes
- Incorrect breaker setting

IV. Starter Motor – If There Is Excessive Current Draw, Check for:

- Broken, jammed starter drive
- Dirty, gummed armature
- Shorted armature
- Grounded armature or field
- Resistance from engine
- Misaligned starting motor
- Worn armature shaft bearings
- Misaligned armature shaft
- Loose field pole pieces

SERVICE HINTS – Cont'd.

IV. Starter Motor (Cont'd)

If Starter Fails to Operate, Check For:

- Poor battery ground
- Jammed drive
- Broken teeth on flywheel
- Direct ground in switch
- Solenoid dead or shorted
- Burned contact points in switch
- Improper seating brushes
- High mica between commutator segments
- Shorted armature
- Shorted field or brushes

V. Distributor System Failures – With Ignition System as Guide, If There Is Breaker Point Oxidation, Check For:

- High battery voltage
- Resistor of incorrect capacity
- High resistance in condenser circuit
- Incorrect type ignition coil
- Extremely high voltage
- Moisture formation
- Excessive heat from engine

VI. Electrical Failures – If Frequent Battery Charge Is Necessary, Check For:

- Corroded battery terminals
- Alternator grounded or shorted
- Worn out, inefficient battery
- Rectifier defective
- Short circuit in charging system
- Excessive use of electrical units
- Short circuit in ignition switch

AMC - "SABER"

Model No.	H. P.	Year	Magneto No.	Coil No.	Operating Amperage	Continuity Min. Max.	Condenser No.	Capactiy Microfarads
3D12M	3	1955	580128	580118	1.6	30 - 40	510173	.18-.22
3D13M	3	1956	580128	580118	1.6	30 - 40	510173	.18-.22
5D11M	5	1955	580183	580118	1.6	30 - 40	510173	.18-.22
5S12M	5	1955-56	580120	580118	1.6	30 - 40	510173	.18-.22
5D12M	5	1956	580182	580118	1.6	30 - 40	510173	.18-.22
12D11M	12	1955	580153	580118	1.6	30 - 40	510173	.18-.22
12D13M	12	1956	580207	580118	1.6	30 - 40	510173	.18-.22
22D10M	22	1955	580180	580118	1.6	30 - 40	510173	.18-.22
22DE10M	22	1955	580180	580118	1.6	30 - 40	510173	.18-.22
22D11M	25	1956	580209	580118	1.6	30 - 40	510173	.18-.22
22D13M	25	1956	580209	580118	1.6	30 - 40	510173	.18-.22
22DE13M	25	1956	580209	580118	1.6	30 - 40	510173	.18-.22

ATLAS - "ROYAL"

Model No.	H.P.	Year	Magneto No.	Coil No.	Operating Amperage	Continuity Min. Max.	Condenser No.	Capacity Microfarads
3D11A	3	1953-55	580128	580118	1.6	30 - 40	510173	.18-.22
3D12A	3	1955	580128	580118	1.6	30 - 40	510173	.18-.22
3D13A	3	1956	580128	580118	1.6	30 - 40	510173	.18-.22
5S11A	5	1955	580120	580118	1.6	30 - 40	510173	.18-.22
5D11A	5	1955	580183	580118	1.6	30 - 40	510173	.18-.22
5D12A	5	1956	580120	580118	1.6	30 - 40	510173	.18-.22
5D13A	5	1956	580182	580118	1.6	30 - 40	510173	.18-.22
12D11A	12	1954-55	580153	580118	1.6	30 - 40	510173	.18-.22
12D13A	12	1956	580207	580118	1.6	30 - 40	510173	.18-.22
22D10A	22	1955	580180	580118	1.6	30 - 40	510173	.18-.22
22DE10A	22	1955	580180	580118	1.6	30 - 40	510173	.18-.22
22D12A	22	1955	580180	580118	1.6	30 - 40	510173	.18-.22
22DE12A	22	1955	580180	580118	1.6	30 - 40	510173	.18-.22
25D11A	25	1956	580209	580118	1.6	30 - 40	510173	.18-.22
25D13A	25	1956	580209	580118	1.6	30 - 40	510173	.18-.22
25DE11A	25	1956	580209	580118	1.6	30 - 40	510173	.18-.22
25DE13A	25	1956	580209	580118	1.6	30 - 40	510173	.18-.22

AUTO LITE - FORD

Part No.	Capacity in Microfarads	Part No.	Capacity in Microfarads
IAT 3076 Jr	.21- .25	IBB 2042SS	.25- .28
IAT 3076 LA	.25- .28	IGB 1025, E, J.	.20- .25
IBB 2015, L, R.	.25- .28		

AUTOLITE IGNITION COIL

Coil No.	Type	Operating Amperage	Primary Resistance Min. Max.	Secondary Continuity Min. Max.	Condenser No.	Capacity Microfarads Min. Max.
200673		1.1	1.1 - 1.5	60 - 70		
710108		1.1	1.2 - 1.4	60 - 70		

AUTOLITE BALLAST

201010	Resistance	Min. .410	Max. .520
200673	Resistance	Min. .410	Max. .520

FORD PRODUCTS

Part No.	Capacity in Microfarads	Part No.	Capacity in Microfarads
IGA-12300B	.29- .32	7RA-123000	.21- .25
8EL-12300A	.20- .25	FAB-12300A	.21- .25
H-12300	.30- .34	B7A-12300A	.21- .25
7RA-12300B	.21- .25	B7A-12300B	.21- .25

PRESTOLITE (THE ELECTRIC AUTOLITE CO.)

Coil No.	Type	Operating Amperage	Primary Resistance Min. Max.	Secondary Continuity Min. Max.	Condenser No.	Capacity Microfarads Min. Max.
200668	Battery	.8	1.6 - 1.8	55 - 65		
200691	Battery	.57	3.5 - 3.9	55 - 65		
200692	Battery	.7	1.1 - 1.5	55 - 65		

BENDIX SCINTILLA
COIL SPECIFICATIONS

Coil No.	Type	Maximum Amperage
4936	PN	2.30
4998	GN	1.95
5179	MN	2.10
2-306	VAG	1.95
2-751	SF9-SB9	1.90
2-752	VAG	2.10
10-1518	SGA	2.10
10-2160	C-CR-CG	1.60
10-2160	Bendix "C" Series	1.55
10-2160W	Bendix "C" Series	1.35
10-2160Y	Bendix "C" Series	1.60
10-5294	SCA	2.30
10-6710	MN4-6	2.00
10-8548	PC Series	1.75
10-9247	12 Volt Battery Coil	1.10
10-9267	6 Volt Battery Coil	1.45
10-9606	SG Series	1.75
10-13165	SF4-SB5-SB6	1.70
10-13623Y	SF14-1	1.80
10-13624	SCD-1	1.90
10-13625Z	SB14-1	1.80
10-13760	Bendix "C" Series	1.60
10-14856	MN	2.10
10-14857	VMN Series	2.10
10-15829 Y, W, V	PA Series	1.80
10-15829U	PA Series	1.90
10-16144	12 Volt Battery Coil-H Comp.	1.10
10-17288 and Y	CBR Series	1.60
10-17970Y	LA Series	1.00
10-54007	H Series	1.90
10-57460	LA Series	1.35
10-77308	H1 Series	1.60
10-77379	H1 Series	1.60
10-77334	H2 Series (Single SPK)	1.80
10-79157	K Series	2.30
10-81703	VAG Series	2.10
10-82215	K Series	1.60
10-82241	K Series	2.30
10-82259	K Series	2.30
*10-84356Y	K Series	1.80
10-86641	K Series	1.60

*Test with coil on stator plate and insulate between contact points.

BENDIX SCINTILLA
COIL SPECIFICATIONS (Cont'd)

K Series Coil No.	Operating Amperage		Maximum Secondary Continuity
	On Stator Plate	Off Stator Plate	
10-3822	2.0	2.3	60
10-38222Y	2.0	2.3	60
10-50715	1.8	2.1	60
10-70100	1.8	2.1	50
10-70128	1.8	2.1	50
10-70132	1.8	2.1	50
10-70169	1.8	2.1	50
10-70161	2.1	2.4	60
10-70199	2.1	2.4	60
10-94097	1.8		45
10-111287	1.8		58

BENDIX SCINTILLA CONDENSER SPECIFICATIONS

Condenser No.	Type	Minimum Capacity
10-13373Y	VMN Series	.18
10-17453	C Series	.29
10-12049	PA, PB Fixed Spark	.17
10-15061	PA, PB Variable Spark	.17
10-81927	PA6/2F	.17
10-12049	PC	.17
2-755Y	VAG Series	.17
10-82104	H Series	.15
10-55555	H1-21	.14
10-38350W	K Series	.15
10-54916	K Series	.15
10-54954	K Series	.15
10-70141	K Series	.17
10-70162	K Series	.15
10-76413	K Series	.35
10-79125	K Series	.15
10-79168Y	K Series	.27
10-79188	K Series	.15
10-82104	K Series	.13
10-82207	K Series	.29
10-82238	K Series	.15
10-86610	KK Series	.15
10-23186	OA1	.16
10-23186	OA2 (10-20650-2)	.16
10-56546	OA2 (10-32420-1)	.14
10-17453	LA	.29
10-85252	LA	.60
10-81958	LAR	.7
10-81956	LAR	1.5
10-85256	LAR	1.5
10-4341Z	S-1	.15
10-20654	S-1	.20
10-20654	DS-1	.20
10-37626	S4R(L)N-32	.18
10-37626	S6R(L)N-32	.18
10-3159Z	BA Battery Timer	.29
10-53229	SW6LN-12 Battery Timer	.22
10-15061	WN Battery Timer	.17
10-81650	Automag	.18
10-102513	LC	.78
10-102513	DLC L.H.	.78
10-102514	DLC R.H.	.78
10-88603		.23

AMERICAN BOSCH COIL SPECIFICATIONS
FOR MODEL 88 & MODEL 98 MAGNETO IGNITION ANALYZERS

Coil No.	Type	Operating Amperage	Primary Resistance		Secondary Continuity	
			Min.	Max.	Min.	Max.
AA63736	AB33-1922	1.45				
AA68936	AB34	1.55				
AA74709	ZR4 IS	1.45				
AA75795	AT4-AT4/2	1.05				
AA75798	DU4 ED 18 to 36	1.30				
AA75798	ZR4 ED 26	1.30				
AA76184	DU6 ED 18 to 26	1.10				
AA77815	U4 ED 1, 2, 3	.95				
AA77839	U2 ED 1	1.05				
AA78168	U1 ED 1	1.30				
AAB1878	U4 ED 4	.95				
CL521	MJA (Special)	1.30			47 - 57	
CL523	MJA Ed. B & C	1.30			47 - 57	
CL524	MJB, Ed. A, MRF (variable timing)	1.30			52 - 62	
CL527	MJC 4A & 6A	1.11			52 - 62	
CL528	MJC 1A & MJC 1B	1.17			52 - 62	
CL529	MJA (Special)	1.15			47 - 57	
CL5210	MJC 6A	1.10			--	
CL5217	RF 41, 42 ED. 1	1.85			--	
CL5220	MJA, Heavy Duty	1.00			--	
CL5231	MJC 4A, 6A, 4B, 6B	1.11			52 - 62	
CL5234	MVA 2A, 2A 310, 6A 2108	1.40			52 - 62	
CL5236	MVA 1A, 1A 310, 6A 2108	1.40			--	
CL5238	MJC, Ed. C, 4C & 6C	1.30			52 - 62	
CL5239	MJH 1C	1.30			--	
CL5244	MJD	1.65			--	
CL5246	MVA Ed. A	1.40			--	
CL5249	MJC Ed. C	1.30			--	
CL5286	MJC Ed. C	1.30			52 - 62	
CL5293	MJH 2 C	1.70			--	
CL5297	MJC Ed. C	1.30			--	
CL5298	MJK Ed. A & B	1.40			50 - 60	
CL52107	MRF, MJB, ED. B, 4 cyl (fixed timing)	1.30			52 - 62	
CL52109	MJA Ed. D	1.30			47 - 57	
CL52112	MJH	1.40			50 - 60	
CL52115	MRD	1.30			52 - 62	
CL52116	MJA	1.30			50 - 60	
CL52117	MRD	1.45			48 - 58	
CL52118	MRA, Ed. A	1.30			52 - 62	
CL52119	MJH 4C	1.30			47 - 57	
CL52121	MJC Ed. C	1.30			52 - 62	
CL52127	MJC Ed. C	1.30			52 - 62	
CL52134	MJH, MRD	1.45			48 - 58	
CL52137	MRD	1.45			48 - 58	
CL52141	MJA Ed. D	1.30			47 - 57	
CL52143	MRD Ed. A	1.45			48 - 58	
CL52145	MRE Ed. A	1.40			48 - 58	
CL52158	MRB with CLC 6	1.70			Off Scale	
CL52158	MRB with CLC 12	1.70			Off Scale	
CL52158	MRB with CLT 40	2.20			Off Scale	
CL52159	MRB with CLC 6	1.70			Off Scale	
CL52159	MRB with CLC 12	1.70			Off Scale	
CL52159	MRB with CLT 40	2.20			Off Scale	
CL52162	MSB with CLC 6	1.5			Off Scale	

AMERICAN BOSCH COIL SPECIFICATIONS
FOR MODEL 88 & MODEL 98 MAGNETO IGNITION ANALYZERS (Cont'd)

Coil No.	Type	Operating Amperage	Primary Resistance		Secondary
			Min.	Max.	Continuity Min. Max.
CL52162	MSB with CLC 12	1.3			Off Scale
CL52162	MSB with CLT 40	1.9			Off Scale
CL52163	MJA with CLC 6	2.0			Off Scale
CL52163	MJA with CLC 12	2.0			Off Scale
CL52163	MJA with CLT 40	2.7			Off Scale
CL52164	MRA Ed. B, MJK	1.30			52 - 62
CL52165	MRA, MJA	1.30			52 - 62
CL52166	MRA	1.30			52 - 62
CL52167A	MRA	1.30			52 - 62
CL52168A	MRA	1.30			52 - 62
CL52172	MJB with CLC 6	1.7			Off Scale
CL52172	MJB with CLC 12	1.7			Off Scale
CL52172	MJB with CLT 40	2.2			Off Scale
CL52173	MRL with CLC 6	1.7			Off Scale
CL52173	MRL with CLC 12	1.7			Off Scale
CL52173	MRL with CLT 40	2.2			Off Scale
CL521001	MJF (Special)	1.30			52 - 62
CL521005A		1.5	.4	.5	50 - 60
CLC6A	Low tension mag. Ign. transformer	.98			
CLC6A 5	Low tension mag. Ign. transformer	.98			
CLC6A 8	Low tension mag. Ign. transformer	.98			
CLC12A55		.7	3	4	45 - 55
CLT10A15		.8	10	12	45 - 55
SA75393	FY ED 2	2.00			
SA78081	FY 12 ED 2, 3, 4	2.05			
SA78308	FY2, 6, 13, 17, 28, 36	2.20			
SA79555	FY 18 ED 1	1.80			
SA81426	FY 30 ED 1	1.30			
SA81603	FY 33 ED 1	2.00			
SA82995	S ED 1	.82			
SA83054	FY 37 ED 1	1.97			
SA84383	RF 17 ED 1	2.25			
WC2580	ZEV	1.50			
WC2594	AB 33-AB34-BA-AZ	1.45			
WC6040	AB34	1.45			
WC69342	FXI, 2, SPK-FBC 2 SPK	2.10			
WC73360	DU4 & 6-ZR 4 & 6	1.15			
WC74792	AT 4 & 6	1.05			
WC76104	FBC, FXI-FH-FB 1 & 2	1.50			
WC77803	U4 ED 1, 2, 3, F1	1.05			
WC79444	U6 ED 1	.98			
WC82913	SU4, ED 1, 2, 3, 4	1.05			
WC82995	S ED 1	.82			
WC86187	U4 ED 2 (LOW SPEED)	1.00			
WC86188	U 4/2-U4, ED 2 and 4 (low speed)	1.00			

AMERICAN BOSCH CONDENSER SPECIFICATIONS
FOR MODEL 88 & MODEL 98 MAGNETO IGNITION ANALYZERS

Condenser No.	Variation Condenser	Magneto	Capacity Reading in Microfarads	
			Min.	Max.
CW522			.33	.39
CW527		MJC	.22	.27
	CW5232	MJC	.22	.27
	CW5279	MRD, MSA	.22	.27
	CW5293	MRD	.22	.27
	CW52131	MSB	.22	.27
CW5210		MJA, MJB, MJF, MRA, MRF	.33	.39
	CW5291	MJA, MJB, MJF, MRA, MRF	.33	.39
	CW5296	MJA, MJB, MJF, MRF, MRA	.33	.39
	CW5298	MJA, MJB, MJF, MRA, MRF	.33	.39
CW5224			.22	.27
CW5232			.22	.27
CW5249		MRB	.70	.85
CW5250			.22	.27
CW5252		MJF	.33	.39
CW5260			.22	.27
CW5263			.22	.27
CW5279			.22	.27
CW5291			.33	.39
CW5292			.28	.35
CW5293			.22	.27
CW5296			.33	.39
CW5297		MRB, MRL	.70	.85
CW5298			.33	.39
CW5299			.70	.85
CW52110		MJK	.28	.35
	CW5292	MJK	.28	.35
CW52131			.25	.28

ROBERT BOSCH COIL SPECIFICATIONS (GERMAN)

Coil No.	Ski-Doo No.	Operating Amperage	Primary Resistance		Secondary Continuity	
			Min.	Max.	Min.	Max.
*0-221-500-800	4027008	0.6	1.6	2.0	50	60
*2-204-211-005		1.0	1.6	1.8	40	50
*2-204-210-013	4024038	1.0	1.8	2.1	35	45
2-204-210-041		1.0			45	55
*2-204-211-008	4024040	1.0	1.5	1.9	40	50
*2-204-211-029		1.5	.7	1.3	35	45
2-204-211-030		1.7	.4	.5	45	55
2-204-211-070		1.5			45	55
2-204-710-041 (Polaris) Red Core		1.2	1.7	2.1	40	50
000-43-05.554 (Polaris) Green Core		.65	1.7	2.1	40	50
5034T2 (Polaris)			1.7	2.1	40	50
MZAN4T-12 "Red Core" (Polaris)		1.2	.6	.9	45	55
MZAN4T-12 "Green Core" (Polaris)		.65	1.7	2.1	40	50
*TJ 12/1		.7	2.9	3.5	45	60
*TK 12A3		.7	3.2	3.6	50	60
9B00B		1.3			40	50
10B0		1.2			50	60
13B00		1.5			45	55
*0-212-940-001	4027008	0.6	1.6	2.0	50	60

GERMAN BOSCH LIGHTING COIL SPECIFICATIONS

Coil No.	Ski-Doo No.	Operating Amperage	Resistance
1-214-210-042	4024083		.4
1-214-216-160	4024084		.7
	4027014	Short Lead	1.2
1-214-210-163	and	2-Leads	
	4027015	Long Lead	1.0
1-214-210-056			.8

GERMAN BOSCH CONDENSER SPECIFICATIONS

Condenser No.	Ski-Doo No.	Capacity Reading in Microfarads	
		Min.	Max.
1-237-330-035	4024067 7	.13	.17
1-237-330-037 (Polaris)	4024068 8	.26	.30
1 LMK01Z32 (Polaris)		.23	.27
9B01		.14	.18
10B00		.11	.15
1237-330-036		.11	.15
1217-330-048		.11	.15

*NOTE: To test coil, disconnect the 7-1/2 volt internal battery and connect leads to a 12 volt battery for coil power test only.

CAUTION: DO NOT USE THE 12 VOLT BATTERY FOR ANY OTHER TESTS.

ROBERT BOSCH COIL SPECIFICATIONS (GERMAN)

Coil No.	Type	Operating Amperage
WZ8164	DR2 spk.	1.50
ZA27279/7	Z4-Z6	1.30
ZA27279/8	ZR-ZU4, 6 Dual	1.20
ZA27279/9	P29h2-V1-V2	1.30
ZA27279/11	Z2 spk.	1.40
ZA27279/12	ZU-4, 6-ZR4, 6-2 spk.	1.20
ZA29035	ZR6-2	1.20
ZA29192	P22h2-V1-V2	1.30
ZA29244	P30h2-V1	1.60
ZA29362	DU4, 6, ZR4, 6 DR4	1.55
ZAK1/15	FF4, 6, PF4A, FF6A	1.75
ZAK1/16	FF1, 2-FFV	1.75
ZAK1/18	FF1A-FF2A-FFVA	1.75
ZAK2/11	FFC1-FFC1A-FFC1AR	1.30
ZAK4/11	FR4, 6-FR4A-FR4B	.95
ZAK10/11	FU4, 6-FU4A, FU4B, FU6B	1.25

ROBERT BOSCH (GERMAN)

Coil No.	Operating Amperage	Primary Resistance Min. Max.	Secondary Continuity Min. Max.
TK12A9	1.2	1.7- 2.1	50 - 60
TK6A3	1.2	1.0- 1.4	50 - 60
TK12A11	.7	2.8- 3.3	45 - 55
TK6A11	1.2	1.0- 1.4	45 - 55
TE6B3	1.3	.9- 1.3	40 - 50
TK12A3	.75	3.0- 3.6	50 - 60
TK6A7	1.2	1.0- 1.4	45 - 55

BRIGGS & STRATTON

Model No.	Coil No.	Operating Amperage	Primary Resistance Min. Max.	Secondary Continuity Min. Max.
100200 100900	298316	1.8	.18- .24	25 - 35
60000 80000	298502	1.8	.18- .24	25 - 35
60000 80000	298654	1.8	.18- .24	25 - 35
243000	298968	1.6	.18- .24	40 - 50
144000	298968	1.6	.18- .24	40 - 50
145000	298968	1.6	.18- .24	40 - 50
146000	298968	1.6	.18- .24	40 - 50
147000	298968	1.6	.18- .24	40 - 50
193000	298968	1.6	.18- .24	40 - 50
233000	298968	1.6	.18- .24	40 - 50

Condenser No.	Capacity Microfarads
29861	.16- .26
291369	.16- .26
294-628	.16- .26

BRIGGS & STRATTON MAGNETO COIL SPECIFICATIONS

Coil No.	Engine Models	Operating Amperage	Primary Resistance Min. Max.	Secondary Continuity Min. Max.
291617-A		1.7	.25 .35	45 55
291617	6-6B	1.7	.3 .5	35 45
292184	6-6B			
294319	6B			
295680	6B			
295845	140000-141000-142000-143000			
296034	6B			
296171	80600-81600-80800-81800-84500- 85500-84900-85900			
296703	140000-141000-142000-143000			
296834	140000-141000-142000-143000			
296858	60000-80000			
297320	140000-141000-142000-143000			
297594	100200-100900	1.7	.28 .34	50 60
290830	9-14-19-23	1.15		36 56
29656	A-B-ZZ	.5	.6 .8	40 50
29657	A-B-ZZ			
293289	A-B-ZZ			
*295915	6B	2.0	.2 .35	40 50
*293431	9-14-19-23	1.2	.5 .7	50 60
297307	60000-80000			
(Use 298502)		1.6	.2 .3	25 35
298274	60000-80000			
298316	100200-10900	1.8	.18 .24	25 35
298443	60000-80000			
298502	60000-80000	1.6	.2 .3	25 35
298524	100200-100900			
298654	60000-80000			
298968	144000-145000-146000-147000 193000-233000-243000	1.4	.2 .3	40 50
299366		1.5	.22 .28	37 47

*NOTE: Double lead secondary (see page 23, Figure 26 for Test Procedure.)

BRITISH SEAGULL

Coil No.	Operating Amperage	Primary Resistance Min. Max.	Secondary Resistance Min. Max.	Condenser No.	Capacity Microfarads Min. Max.
AM1634E	2.0	.28- .32	30 - 40	Villiers	.20- .26

BRIDGESTONE BY ROCKFORD MOTORS INC.

Model No.	Mfgr.	Coil No.	Type	Oper. Amps	Primary Resistance Min. Max.	Secondary Continuity Min. Max.	Condenser No.	Capacity Microfarads Min. Max.
BS-HM/S 50 Leader	Rockford	GA1-1721I E1922I	Ignition Lighting	1.5	1.0-1.2 .05	35 - 45	E1924I	.25- .30
BS-7S Sportster Std.	Rockford	GA1-1721I E1922I	Ignition Lighting	1.5	1.0-1.2 .05	35 - 45	E1924I	.25- .30
BS-7D Sportster Del.	Rockford	E0930I	Ignition	.6	5.4-6.7	50 - 60	E09105	.25- .30
BS-90 BS-90T BS-90M BS-90 Sport.	Rockford	EA1-89310	Ignition	.7	2.0-2.5	55 - 65	EA1-1724I	.25- .30
BS-90 BS-90T BS-90M BS-90 Sport.	Rockford	EA1-17212	Ignition Primary		.6-.7			
BS-50S BS-60S Sport.	Rockford	EA1-17213 EA1-38310	Lighting Ignition		.5			
BS-50S BS-60S	Rockford	G81-17212 G82-17213	Ignition Pri. Lighting		.6-.7 .1-.14			
BS-175DT	Rockford	8501-8000	Ignition (2)	.8	4.2-5.2	60 - 70	1753-8000	.25- .30

NOTE: To test above coils, disconnect the internal 7-1/2 volt battery and connect leads to a 12 volt storage battery or equal. Connect our part #55-174 suppressor in series with one test lead. Caution: Do not use the 12 volts for any other tests as all other readings will be incorrect.

BUNDY MARINE

Magneto Coil No.	Mfg. No.	Operating Amperage	Primary Resistance Min. Max.	Secondary Continuity Min. Max.
300-1535	TJ616	.75	3.3- 3.7	55 - 65
Generator Coil No.				Resistance Reading Min. -Max.
300-15034-.55
Low Tension Coil No.				Resistance Reading Min. -Max.
300-1500			1.55-1.85
Diodes No.				Resistance Reading
300-1113			See page 24B for testing.

J. I. CASE COMPANY COIL SPECIFICATIONS

20CMA	4JCMA	1.90
20JMA	4JMA	2.05

CHRYSLER (FORMERLY WEST BEND OUTBOARD MOTORS)

Motor Model No.	H. P.	Year	Wico Coil No.	Operating Amp.	Coil Continuity Min.-Max.	Wico Cond. No.	Cond. Cap. Mfd.
160211	2	1956	X7500	2.10	30 - 50	X5463	.16 - .20
160221	2	1957	X7500	2.10	30 - 50	X9182	.26 - .30
2801	2	1958	X7500	2.10	30 - 50	X9182	.26 - .30
2802	2	1958	X11406	2.10	40 - 60	X11397	.16 - .20
160501	5-1/2	1956	X7500	2.10	30 - 50	X9327	.26 - .30
160511	5-1/2	1956	X7500	2.10	30 - 50	X9327	.26 - .30
160521	6	1957	X7500	2.10	30 - 50	X9327	.26 - .30
160531	6	1957	X7500	2.10	30 - 50	X9327	.26 - .30
6801	6	1958	X7500	2.10	30 - 50	X9327	.26 - .30
6802	6	1958	X11406	2.10	40 - 60	X11397	.16 - .20
160701	7-1/2	1956	X7500	2.10	30 - 50	X9327	.26 - .30
160711	7-1/2	1956	X7500	2.10	30 - 50	X9327	.26 - .30
160721	8	1957	X7500	2.10	30 - 50	X9327	.26 - .30
160731	8	1957	X7500	2.10	30 - 50	X9327	.26 - .30
8801	8	1958	X7500	2.10	30 - 50	X9327	.26 - .30
8802	8	1958	X11406	2.10	40 - 60	X11397	.16 - .20
160902	12	1956	X7500	2.10	30 - 50	X9327	.26 - .30
160912	12	1956	X7500	2.10	30 - 50	X9327	.26 - .30
160941	12	1957	X7500	2.10	30 - 50	X9327	.26 - .30
160951	12	1957	X7500	2.10	30 - 50	X9327	.26 - .30
12801	12	1958	X7500	2.10	30 - 50	X9327	.26 - .30
12811	12	1958	X7500	2.10	30 - 50	X9327	.26 - .30
12802	12	1958	X11406	2.10	40 - 60	X11397	.16 - .20
12812	12	1958	X11406	2.10	40 - 60	X11397	.16 - .20
35841	35	1958	X11563	0.75	50 - 60	X11337	.26 - .30
35851	35	1958	X11563	0.75	50 - 60	X11337	.26 - .30
35861	35	1958	X11563	0.75	50 - 60	X11337	.26 - .30
35871	35	1958	X11563	0.75	50 - 60	X11337	.26 - .30

CHRYSLER (FORMERLY WEST BEND OUTBOARD MOTORS Cont'd)

Motor Model No.	H.P.	Year	Fairbanks-Morse Coil No.	Operating Amp.	Coil Continuity Min.-Max.	Fairbanks-Morse Cond. No.	Cond. Cap. Mfd.
1609403	25	1956	LX2477	1.50	40 - 60	S2433	.28 - .33
1609413	25	1956	LX2477	1.50	40 - 60	S2433	.28 - .33
1609602	25	1956	LX2477	1.50	40 - 60	S2433	.28 - .33
1609612	25	1956	LX2477	1.50	40 - 60	S2433	.28 - .33
160421	30	1957	LX2477	1.50	40 - 60	S2433	.28 - .33
160431	30	1957	LX2477	1.50	40 - 60	S2433	.28 - .33
160621	30	1957	LX2477	1.50	40 - 60	S2433	.28 - .33
160631	30	1957	LX2477	1.50	40 - 60	S2433	.28 - .33
160801	30	1957	LX2477	1.50	40 - 60	S2433	.28 - .33
160811	30	1957	LX2477	1.50	40 - 60	S2433	.28 - .33
35801	35	1958	LX2477	1.50	40 - 60	S2433	.28 - .33
35811	35	1958	LX2477	1.50	40 - 60	S2433	.28 - .33
35821	35	1958	LX2477	1.50	40 - 60	S2433	.28 - .33
35831	35	1958	LX2477	1.50	40 - 60	S2433	.28 - .33
			WICO			WICO	
BATTERY IGNITION	40 - 80	1957-60	X11563	0.75	50 - 60	X11337	.26 - .30

109

* Wico

CHRYSLER (FORMERLY WEST BEND OUTBOARD MOTORS Cont'd)

** Fairbanks-Morse

Motor Model No.	H. P.	Year	Coil No.	Operating Amp.	Continuity Min. Max.	Cond. No.	Cond. Capacity Microfarads
6901	6	1959	* X11406	2.1	40 - 60	* X11397	.16-.20
6911	6	1959	* X11406	2.1	40 - 60	* X11397	.16-.20
6902	6	1959	* X11406	2.1	40 - 60	* X11397	.16-.20
6912	6	1959	* X11406	2.1	40 - 60	* X11397	.16-.20
8901	8	1959	* X11406	2.1	40 - 60	* X11397	.16-.20
8911	8	1959	* X11406	2.1	40 - 60	* X11397	.16-.20
8902	8	1959	* X11406	2.1	40 - 60	* X11397	.16-.20
8912	8	1959	* X11406	2.1	40 - 60	* X11397	.16-.20
12901	12	1959	* X11406	2.1	40 - 60	* X11397	.16-.20
12911	12	1959	* X11406	2.1	40 - 60	* X11397	.16-.20
12902	12	1959	* X11406	2.1	40 - 60	* X11397	.16-.20
12912	12	1959	* X11406	2.1	40 - 60	* X11397	.16-.20
16901	16	1959	* X11406	2.1	40 - 60	* X11397	.16-.20
16911	16	1959	* X11406	2.1	40 - 60	* X11397	.16-.20
16902	16	1959	* X11406	2.1	40 - 60	* X11397	.16-.20
16912	16	1959	* X11406	2.1	40 - 60	* X11397	.16-.20
35901	35	1959	** LX2477	1.5	40 - 60	** S2433	.28-.32
35911	35	1959	** LX2477	1.5	40 - 60	** S2433	.28-.32
35921	35	1959	** LX2477	1.5	40 - 60	** S2433	.28-.32
35931	35	1959	** LX2477	1.5	40 - 60	** S2433	.28-.32
35941	35	1959	** LX2477	1.5	40 - 60	** S2433	.28-.32
35951	35	1959	** LX2477	1.5	40 - 60	** S2433	.28-.32
35961	35	1959	* X11563	.75	50 - 60	* X11337	.26-.30
35971	35	1959	* X11563	.75	50 - 60	* X11337	.26-.30
35981	35	1959	* X11563	.75	50 - 60	* X11337	.26-.30

* Wico

CHRYSLER (FORMERLY WEST BEND OUTBOARD MOTORS Cont'd)

** Fairbanks-Morse

Motor Model No.	H. P.	Year	Coil. No.	Operating Amp.	Continuity Min. Max.	Cond. No.	Cond. Capacity Microfarads
35991	35	1959	* X11563	.75	50 - 60	* X11337	.26-.30
35982	35	1959	* X11563	.75	50 - 60	* X11337	.26-.30
35992	35	1959	* X11563	.75	50 - 60	* X11337	.26-.30
40901	40	1959	** LX2477	1.5	40 - 60	** S2433	.28-.32
40911	40	1959	** LX2477	1.5	40 - 60	** S2433	.28-.32
40902	40	1959	** LX2477	1.5	40 - 60	** S2433	.28-.32
40912	40	1959	** LX2477	1.5	40 - 60	** S2433	.23-.32
40961	40	1959	* X11563	.75	50 - 60	* X11337	.26-.30
40971	40	1959	* X11563	.75	50 - 60	* X11337	.26-.30
40962	40	1959	* X11563	.75	50 - 60	* X11337	.26-.30
40972	40	1959	* X11563	.75	50 - 60	* X11337	.26-.30
40963	40	1959	* X11563	.75	50 - 60	* X11337	.26-.30
40973	40	1959	* X11563	.75	50 - 60	* X11337	.26-.30
2901	2	1960	* X11406	2.1	40 - 60	* X11397	.16-.20
7001	7-1/2	1960	* X11406	2.1	40 - 60	* X11397	.16-.20
7002	7-1/2	1960	* X11406	2.1	40 - 60	* X11397	.16-.20
8001	8	1960	* X11406	2.1	40 - 60	* X11397	.16-.20
12021	12	1960	* X11406	2.1	40 - 60	* X11397	.16-.20
12031	12	1960	* X11406	2.1	40 - 60	* X11397	.16-.20
18001	18	1960	* X12302	2.2	40 - 55	* X12303	.16-.20
18011	18	1960	* X12302	2.2	40 - 55	* X12303	.16-.20
25021	25	1960	** LX2477	1.5	40 - 60	** S 2433	.28-.32
25031	25	1960	** LX2477	1.5	40 - 60	** S 2433	.28-.32
40001	40	1960	** LX2477	1.5	40 - 60	** S 2433	.28-.32
40011	40	1960	** LX2477	1.5	40 - 60	** S 2433	.28-.32

* Wico

CHRYSLER (FORMERLY WEST BEND OUTBOARD MOTORS Cont'd)

** Fairbanks-Morse

Motor Model No.	H. P.	Year	Coil No.	Operating Amp.	Continuity Min.-Max.	Cord. No.	Cond. Capacity Microfarads
40021	40	1960	** LX2477	1.5	40 - 60	** S2433	.28-.32
40031	40	1960	** LX2477	1.5	40 - 60	** S2433	.28-.32
40061	40	1960	* X11563	.75	50 - 60	* X11337	.26-.30
40071	40	1960	* X11563	.75	50 - 60	* X11337	.26-.30
2101	2	1961	* X12660	1.8	40 - 55	* X12174	.16-.20
2102	2	1961	* X11406	2.1	40 - 60	* X11397	.16-.20
7001	7-1/2	1961	* X11406	2.1	40 - 60	* X11397	.16-.20
7002	7-1/2	1961	* X11406	2.1	40 - 60	* X11397	.16-.20
12101	12	1961	* X11406	2.1	40 - 60	* X11397	.16-.20
12102	12	1961	* X11406	2.1	40 - 60	* X11397	.16-.20
18101	18	1961	* X12302	2.2	40 - 55	* X12303	.16-.20
18111	18	1961	* X12302	2.2	40 - 55	* X12303	.16-.20
18102	18	1961	* X12302	2.2	40 - 55	* X12303	.16-.20
18112	18	1961	* X12302	2.2	40 - 55	* X12303	.16-.20
25121	25	1961	** LX2477	1.5	40 - 60	** S2433	.28-.32
25131	25	1961	** LX2477	1.5	40 - 60	** S2433	.28-.32
25122	25	1961	** LX2477	1.5	40 - 60	** S2433	.28-.32
25132	25	1961	** LX2477	1.5	40 - 60	** S2433	.28-.32
40101	40	1961	** LX2477	1.5	40 - 60	** S2433	.28-.32
40111	40	1961	** LX2477	1.5	40 - 60	** S2433	.28-.32
40102	40	1961	** LX2477	1.5	40 - 60	** S2433	.28-.32
40112	40	1961	** LX2477	1.5	40 - 60	** S2433	.28-.32
40121	40	1961	** LX2477	1.5	40 - 60	** S2433	.28-.32
40131	40	1961	** LX2477	1.5	40 - 60	** S2433	.28-.32
40122	40	1961	** LX2477	1.5	40 - 60	** S2433	.28-.32
40132	40	1961	** LX2477	1.5	40 - 60	** S2433	.28-.32

1966 CHRYSLER OUTBOARD CORP.

Model No.	H. P.	Coil No.	Oper. Amp.	Primary Resistance		Secondary Continuity		Condenser No.	Capacity Microfarads	
				Min.	Max.	Min.	Max.		Min.	Max.
360	3.5	X12940	1.5	.45-	.65	50 -	60	X12174	.16-	.20
361	3.5	X12940	1.5	.45-	.65	50 -	60	X12174	.16-	.20
660	6.0	X14877	1.4	.4 -	.6	50 -	60	X11397	.16-	.20
960	9.2	X14877	1.4	.4 -	.6	50 -	60	X11397	.16-	.20
964	9.2	X14877	1.4	.4 -	.6	50 -	60	X11397	.16-	.20
2060	20.0	X14381	1.4	.4 -	.6	50 -	60	X12303	.16-	.20
2061	20.0	X14381	1.4	.4 -	.6	50 -	60	X12303	.16-	.20
2064	20.0	X14381	1.4	.4 -	.6	50 -	60	X12303	.16-	.20
3401		X12660	1.8			40 -	55	X12174	.16-	.20
3560	35.0	TX2477	1.5	.62-	.68	45 -	55	S2433	.28-	.32
3563	35.0	TX2477	1.5	.62-	.68	45 -	55	S2433	.28-	.32
4562	45.0	TX2477	1.5	.62-	.68	45 -	55	T12042	.30-	.33
4563	45.0	TX2477	1.5	.62-	.68	45 -	55	T12042	.30-	.33
5062	50.0	TX2477	1.5	.62-	.68	45 -	55	X11337	.26-	.30
5063	50.0	TX2477	1.5	.62-	.68	45 -	55	X11337	.26-	.30
5066	50.0	TX2477	1.5	.62-	.68	45 -	55	S2433	.28-	.33
5067	50.0	TX2477	1.5	.62-	.68	45 -	55	S2433	.28-	.33
6401		X11406	2.1			40 -	60	X11397	.16-	.20
7566	75.0	A85475-1	1.0	1.6-	2.0	63 -	73	14022	.38-	.40
7567	75.0	A85475-1	1.0	1.6-	2.0	63 -	73	14022	.38-	.40
10401-										
10403		X11406	2.1			40 -	60	X11397	.16-	.20
10566	105.0	A85475-1*12V	1.0	1.7-	2.3	65 -	75	14022	.38-	.40
10567	105.0	A85475-1*12V	1.0	1.7-	2.3	65 -	75	14022	.38-	.40
20401		X14381	1.4	.4 -	.6	50 -	60	X12303	.16-	.20
35401-										
35431		TX2477	1.5	.62-	.68	45 -	55	S2433	.28-	.36
45421-										
45431										
45423-										
45433		TX2477	1.5	.62-	.68	45 -	55	S2433	.28-	.36
50421-										
50431		TX2477	1.5	.62-	.68	45 -	55	S2433	.28-	.36
50461-										
50471		X11563	0.75			40 -	60	X11337	.26-	.30
80461-										
80471		X11563	0.75			40 -	60	X12647	.26-	.30
80242-										
80252		X11563	0.75			40 -	60	X12647	.26-	.30
9501		X11406	2.1			40 -	60	X11397	.16-	.20

CHRYSLER (FORMERLY WEST BEND
INDUSTRIAL ENGINES)

* Wico

** Fairbanks-Morse

Motor Model No.	Coil No.	Operating Amp.	Coil Continuity Min.-Max.	Cond. No.	Cond. Capacity Microfarads
2725	* X11260	1.8	40 - 55	* X11000	.16-.23
2760	* X11260	1.8	40 - 55	* X11000	.16-.23
2761	* X11260	1.8	40 - 55	* X11000	.16-.23
27612	* X11260	1.8	40 - 55	* X11000	.16-.23
2762	* X11260	1.8	40 - 55	* X11000	.16-.23
2763	* X11260	1.8	40 - 55	* X11000	.16-.23
2764	* X11260	1.8	40 - 55	* X11000	.16-.23
2785	* X9055	2.1	35 - 55	* X9100	.26-.30
27882	* X11260	1.8	40 - 55	* X11000	.16-.23
27883	* X11260	1.8	40 - 55	* X11000	.16-.23
27812	* X11260	1.8	40 - 55	* X11000	.16-.23
27813	* X11260	1.8	40 - 55	* X11000	.16-.23
27822	* X11260	1.8	40 - 55	* X11000	.16-.23
27823	* X11260	1.8	40 - 55	* X11000	.16-.23
27824	* X11260	1.8	40 - 55	* X11000	.16-.23
27825	* X11260	1.8	40 - 55	* X11000	.16-.23
27854	* X11260	1.8	40 - 55	* X11000	.16-.23
58001	* X11260	1.8	40 - 55	* X11000	.16-.23
58002	* X11260	1.8	40 - 55	* X11000	.16-.23
58003	* X11260	1.8	40 - 55	* X11000	.16-.23
58004	* X11260	1.8	40 - 55	* X11000	.16-.23
58006	* X11260	1.8	40 - 55	* X11000	.16-.23
58007	* X11260	1.8	40 - 55	* X11000	.16-.23
58008	* X11260	1.8	40 - 55	* X11000	.16-.23
58009	* X11260	1.8	40 - 55	* X12508	.16-.20
58010	* X11260	1.8	40 - 55	* X12508	.16-.20
58011	* X11260	1.8	40 - 55	* X12508	.16-.20
58012	* X11260	1.8	40 - 55	* X12508	.16-.20
58013	* X11260	1.8	40 - 55	* X12508	.16-.20
58015	* X11260	1.8	40 - 55	* X12508	.16-.20
58016	* X11260	1.8	40 - 55	* X11000	.16-.23
58017	* X11260	1.8	40 - 55	* X11000	.16-.23
70001	* X11260	1.8	40 - 55	* X11000	.16-.23
70002	* X11260	1.8	40 - 55	* X11000	.16-.23
70006	* X11260	1.8	40 - 55	* X12508	.16-.20
70007	* X11260	1.8	40 - 55	* X11000	.16-.23
70008	* X11260	1.8	40 - 55	* X11000	.16-.23
70009	* X11260	1.8	40 - 55	* X12508	.16-.20
70010	* X11260	1.8	40 - 55	* X12508	.16-.20
70012	* X11260	1.8	40 - 55	* X12508	.16-.20
70013	* X11260	1.8	40 - 55	* X12508	.16-.20
61001	* X13313	1.8	50 - 60	* X13299	.16-.20
61002	* X13313	1.8	50 - 60	* X13299	.16-.20
82001	* X13313	1.8	50 - 60	* X13299	.16-.20
82002	* X13313	1.8	50 - 60	* X13299	.16-.20

CHRYSLER (FORMERLY WEST BEND INDUSTRIAL ENGINES Cont'd)

Motor Model No.	Wico Coil No.	Operating Amp.	Coil Continuity Min.-Max.	Wico Cond. No.	Cond. Cap. Mfd.
2700	X7467	1.80	30 - 50	X7461	.10 - .15
2704	X7467	1.80	30 - 50	X7461	.10 - .15
2706	*X9055	2.10	40 - 50	X8959	.16 - .20
2723	*X9055	2.10	40 - 50	X8959	.16 - .20
2726	X11260	1.75	30 - 50	X11000	.16 - .20
2727	X11260	1.75	30 - 50	X11000	.16 - .20
2728	X11260	1.75	30 - 50	X11000	.16 - .20
2729	X11260	1.75	30 - 50	X11000	.16 - .20
2730	X11260	1.75	30 - 50	X11000	.16 - .20
2731	X11260	1.75	30 - 50	X11000	.16 - .20
2732	X11260	1.75	30 - 50	X11000	.16 - .20
2733	X11260	1.75	30 - 50	X11000	.16 - .20
2734	X11260	1.75	30 - 50	X11000	.16 - .20
2735	X11260	1.75	30 - 50	X11000	.16 - .20
2736	X11260	1.75	30 - 50	X11000	.16 - .20
2738	X11260	1.75	30 - 50	X11000	.16 - .20
2740	X11260	1.75	30 - 50	X11000	.16 - .20
2742	X11260	1.75	30 - 50	X11000	.16 - .20
2744	X11260	1.75	30 - 50	X11000	.16 - .20
2752	X7536	1.90	38 - 58	X7529	.16 - .20
2756	*X9055	2.10	35 - 55	X9100	.26 - .30
27562	X11260	1.75	30 - 50	X11000	.16 - .20
2770	X7536	1.90	38 - 58	X9100	.26 - .30
2770	*X9055	2.10	35 - 55	X9100	.26 - .30
2771	*X9055	2.10	35 - 55	X9100	.26 - .30
27712	X11260	1.75	30 - 50	X11000	.16 - .20
2772	X7536	1.90	38 - 58	X9100	.26 - .30
2772	*X9055	2.10	35 - 55	X9100	.26 - .30
2772	X11260	1.75	30 - 50	X11000	.16 - .20
27722	X11260	1.75	30 - 50	X11000	.16 - .20
2774	X7536	1.90	38 - 58	X9100	.26 - .30
2774	*X9055	2.10	35 - 55	X9100	.26 - .30
2774	X11260	1.75	30 - 50	X11000	.16 - .20
27742	X11260	1.75	30 - 50	X11000	.16 - .20
2775	*X9055	2.10	35 - 55	X9100	.26 - .30
2777	X7467	1.80	30 - 50	X7461	.10 - .15
2778	*X9055	2.10	35 - 55	X9100	.26 - .30
2778-1	*X9055	2.10	35 - 55	X9100	.26 - .30
2779	*X9055	2.10	35 - 55	X9100	.26 - .30
2780	*X9055	2.10	35 - 55	X9100	.26 - .30
2781	*X9055	2.10	35 - 55	X9100	.26 - .30
2782	*X9055	2.10	35 - 55	X9100	.26 - .30
2783	*X9055	2.10	35 - 55	X9100	.26 - .30
2784	*X9055	2.10	35 - 55	X9100	.26 - .30
2785	*X9055	2.10	35 - 55	X9100	.26 - .30
27852	X11260	1.75	30 - 50	X11000	.16 - .20
2786	*X9055	2.10	35 - 55	X9100	.26 - .30
2787	*X9055	2.10	35 - 55	X9100	.26 - .30
2788	*X9055	2.10	35 - 55	X9100	.26 - .30
2788	X11260	1.75	30 - 50	X11000	.16 - .20

* Replace with Wico Coil No. X9692.

CLINTON ENGINE CORPORATION
ENGINE DIVISION COIL SPECIFICATIONS

Coil No.	Operating Amperage	Secondary Continuity Min. Max.
135-17-500 (P-5502)	2.8	36 - 56
135-167 (P-5509)	2.8	40 - 60
135-19-500 (P-5531)	2.8	40 - 60
135-169 (P-5538)	2.8	36 - 60
135-2-500 (P-5545)	2.8	36 - 60
135-22-500 (P-5563)	2.2	50 - 70
135-23-500 (P-5593B)	2.8	35 - 60
135-10-500 (P-5733)	2.8	40 - 60
135-13-990 (P-5770)	2.8	40 - 60

CONDENSER SPECIFICATIONS

Condenser No.	Capacity Reading in Microfarads Min. Max.
135-24 (P-2053)	.12 - .16
135-151 (P-3416)	.15 - .19
135-27-500 (P-5549)	.22 - .27
135-29-990 (P5589 & P-5736)	.15 - .19
135-30-500 (P-5599)	.15 - .19
135-26 (P-7219)	.12 - .16

**CLINTON SAW & OUTBOARD DIVISION
COIL SPECIFICATIONS**

Coil No.	Operating Amperage	Secondary Continuity Min. Max.
135-2-500 (P-513)	2.8	40 - 60
135-8-500 (P-400467)	2.8	40 - 60
135-23-500 (P-400789)	2.8	40 - 60
158-321-500 (P-700343)	2.8	40 - 60

CONDENSER SPECIFICATIONS

Condenser No.	Capacity Reading in Microfarads Min. Max.
135-24 (P-261)	.12 - .16
135-29-990 (P-400777)	.15 - .19
135-241-500 (P-700344)	.12 - .16

COMMODORE

* Wico

** Fairbanks-Morse

Motor Model No.	H. P.	Year	Coil No.	Operating Amp.	Continuity Min.-Max.	Cond. No.	Cond. Capacity Microfarads
23201	2	1961 & 1962	* X12660	1.8	40 - 55	* X12174	.16-.20
73201	7-1/2	1961 & 1962	* X11406	2.1	40 - 60	* X11397	.16-.20
103201	10	1961 & 1962	* X11406	2.1	40 - 60	* X11397	.16-.20
183201	18	1961 & 1962	* X12302	2.2	40 - 55	* X12303	.16-.20
403201	40	1961 & 1962	** LX2477	1.5	40 - 60	** S2433	.28-.32

CONTINENTAL MOTORS
COIL SPECIFICATIONS

Coil No.	Manufacturer's No.	Operating Amperage	Continuity Min. Max.
AA7M3260 . . .	Smith	1.30	30 - 50
X6111	1.60
AA7M2210 . . .	AA7M3260	1.30	30 - 50
X6718	1.80
X7536	1.90	38 - 58
X7680	1.80
FG-4638	2.80	40 - 60

CONTINENTAL MOTORS
CONDENSER SPECIFICATIONS

Condenser No.	Capacity Microfarads
AA7-M-2980225-.275

CUSHMAN MOTORS

Coil No.	Operating Amperage	Primary Resistance Min. Max.	Secondary Continuity Min. Max.	Condenser No.	Capacity Microfarads Min. Max.
580346	1.5	.4- .6	40 - 50	510478	.33- .41
580380	1.0	.6- .8	70 - 80	510613	.18- .22
580600	.75	.9- .15	60 - 70		

DELCO-REMY IGNITION COIL SPECIFICATIONS

Coil No.	Type	Operating Amperage	Primary Resistance Min. Max.	Secondary Continuity Min. Max.
1115153	Battery	.9	1.65-1.95	50 - 60
1115032		.5	3.9 -4.3	48 - 58
1115106		.9		55 - 65
1115043		.55	3.5 -4.5	39 - 49

DELCO-REMY CONDENSER SPECIFICATIONS

Condenser No.	Capacity Reading in Microfarads Min. Max.
1869704	.18- .23
1869705	.18- .23
1869706	.18- .23
1871678	.18- .23
1882239	.29- .34
1900272	.18- .23
1928111	.18- .23
1932004	.18- .23
1942948	.18- .23
1965489	.18- .23

EATON - VOLVO 110 AQUAMATIC

Coil No.	Operating Amperage	Primary Resistance Min. Max.	Secondary Continuity Min. Max.	Condenser No.	Capacity Microfarads Min. Max.
TK12A3	.6	3.2- 3.6	50 - 60		
200691 1000281 6024	.57	3.5- 3.9	55 - 65		
200692 (Presolite) 1000193 (Eaton)	.7	1.1- 1.5	55 - 65	238852	.21- .28

Resistor No.	Resistance Min. Max.
201016	.49- .55

ECHLIN CONDENSER SPECIFICATIONS

Cond. No.	Capacity Mfd.	Cond. No.	Capacity Mfd.
13-200	.30-.36	29-200	.18-.22
13-201	.22-.25	29-201	.30-.36
13-202	.22-.25	37-200	.17-.21
13-203	.22-.25	37-201	.17-.21
13-204	.22-.25	73-200	.17-.21
13-205	.30-.36		
25-200	.18-.21		
25-201	.18-.22		

EDISON-SPLITDORF COIL SPECIFICATIONS

Coil No.	Type	Maximum Amperage
EX 4161	M1 & 2, AE2	1.70
EX 6178	R	1.35
EX 6406	RM4, RMG2	1.40
EX 6435	RM1, RM2	1.40
EX 6951	RMP-4 VAR.	1.40
EX 6991	RM-2, RMP-2	1.40
EX 7746	C4, C6, CO	1.35
EX 23263	601, 700-702	2.00
EX 23579	235	1.45
EX 33740	GH1	1.00
EX 33795	GH2	1.00
EX 36034	All Dixie	1.90
EX 36161	648T	1.55
EX 50060	S1, 2, 4, SPO, SP1	1.10
EX 50643	NS1	1.10
EX 51116	NS2, NS4	1.25
EX 51432	C2	1.10
EX 51446	CDH	1.20
EX 53315	K4	1.40
EX 60025	SSO	1.20
EX 60060	SS4-6	1.10
EX 62190	SS6-2 (Firing 2 Sparks)	1.50
EX 63585	B2, B3, B4, B6	1.20
EX 72080	AJ1	2.35
EX 72223	AJ2	2.35
EX 72288	AJ1 & 2	2.00

EISEMANN FLYWHEEL MAGNETO COIL SPECIFICATIONS

COMPLETE STATOR

COIL & CORE ASSEMBLY

Model Magneto	Principal User	Part No.	Amperage On		Part No.	Amperage On	
			Round Core	Square Core		Round Core	Square Core
51-A	Muncie	H23-495	----	1.90	H23-460	----	1.60
51-B	Sears	H23-499	----	1.90	H23-460	----	1.60
51-C	Sears	H23-454	----	1.90	H23-460	----	1.60
51-D	Sears	H23-538	----	1.90	H23-460	----	1.60
51-E	Clarke	H24-031	----	1.90	H23-460	----	1.60
51-F	Homelite	H24-701	----	1.90	H24-703	----	1.60
51-FS	Homelite	H26-662	----	1.90	H24-703	----	1.60
51-G	Sears	H24-833	----	1.90	H23-460	----	1.60
51-H	Sears	H24-831	----	1.90	H23-460	----	1.60
51-J	Muncie	H24-813	----	1.90	H23-460	----	1.60
51-K	Chic. Pneum.	H27-640	----	1.90	H23-460	----	1.60
51-KA	Gary Steel	H27-640	----	1.90	H23-460	----	1.60
51-M	Homelite	H27-349	----	1.90	H23-460	----	1.60
61-A	Lauson	H23-007	1.95	1.75	H23-010	1.70	1.50
	Latter Edition	H23-007	----	1.75	H24-820	----	1.50
61-B	Muncie	H23-034	2.00	1.80	H23-010	1.70	1.50
	Latter Edition	H23-034	----	1.75	H24-820	----	1.50
61-C	Sears	H23-072	2.00	1.80	H23-010	1.70	1.50
	Latter Edition	H23-072	----	1.75	H24-820	----	1.50
61-D, DA	Lauson	H23-231	----	1.75	-----	----	----
61-DAG	Lauson	H24-712	----	1.75	-----	----	----
61-DAL	Lauson	H24-239	----	1.75	-----	----	----
61-DC	Jacobsen	H23-231	----	1.75	-----	----	----
61-DD	Reo Motors	H23-231	----	1.75	-----	----	----
61-E	Champion	H24-023	1.95	1.75	H23-010	1.70	1.50
			----	1.75	H24-820	----	1.50
61-F	Muncie	H24-793	----	1.75	H24-820	----	1.50

NOTE: Coils such as the H27-894 can only be tested in assembly with the laminated core or complete stator assembly.

EISEMANN FLYWHEEL MAGNETO COIL SPECIFICATIONS (Cont'd)

COMPLETE STATOR

COIL & CORE ASSEMBLY

Model Magneto	Principal User	Part No.	Amperage On		Part No.	Amperage On	
			Round Core	Square Core		Round Core	Square Core
61-G	Sears	H24-879	---	1.75	H24-820	---	1.50
61-GL	Sears	H24-801	---	1.75	H24-820	---	1.50
61-H	Mtgy.-Ward	H24-793	---	1.75	H24-820	---	1.50
61-J	Metal Prod.	H27-659	---	1.90	H26-034	---	1.60
61-K	Kiekhoefer	H24-838	---	1.75	H24-820	---	1.50
61-M	Scott-Atwater	H24-879	---	1.75	H24-820	---	1.50
62-A	Muncie	H26-028	---	1.90	H26-034	---	1.60
62-B	Metal Prod.	H27-645	---	1.90	H26-034	---	1.60
62-D	Lauson	H27-932	---	2.20	---	---	---
71-A	Muncie	H21-806	1.95	---	H21-808	1.75	---
71-AA	Muncie	H22-222	1.95	---	H21-808	1.75	---
	Eisemann	H27-894	1.9	---	---	---	---
71-B	Ideal	H21-851	1.95	---	H21-808	1.75	---
71-C	Wisconsin	H21-915	1.95	---	H21-808	1.75	---
71-D	Toro	H22-032	1.95	---	H21-808	1.75	---
71-E	Muncie	H21-938	1.95	---	H21-808	1.75	---
71-F	Toro	H21-984	1.25	---	H21-808	1.10	---
71-G	Cushman	H21-996	1.25	---	H21-967	1.10	---
71-H	Muncie	H22-375	1.25	---	H21-808	1.10	---
71-I, M, O	Cushman	H23-128	1.25	---	H21-808	1.10	---
71-J	Onan	H22-063	1.25	---	H21-808	1.10	---
71-K	Muncie	H22-142	1.25	---	H21-808	1.10	---
71-L	Champion	H22-423	1.25	---	H21-808	1.10	---
71-LE	Simplex	H23-181	1.25	---	H21-808	1.10	---
71-M	Lauson	H23-128	---	1.25	H21-808	---	1.10
71-N	Cushman	H23-150	1.25	---	H21-967	1.10	---
71-O	Cushman	H23-128	---	1.25	H21-808	---	1.10

NOTE: Coils such as the H27-894 can only be tested in assembly with the laminated core or complete stator assembly.

EISEMANN FLYWHEEL MAGNETO COIL SPECIFICATIONS (Cont'd)

COMPLETE STATOR

COIL & CORE ASSEMBLY

Model Magneto	Principal User	Part No.	Amperage On		Part No.	Amperage On	
			Round Core	Square Core		Round Core	Square Core
71-P	Cushman	H23-218	1.25	---	H21-967	1.10	---
71-R	Lauson	H23-408	---	1.75	---	---	---
71-RL	Lauson	H24-230	---	1.75	---	---	---
71-RG	Lauson	H24-742	---	1.75	---	---	---
71-S-1-2-3	Nelson, Lauson, Mall Tool	H24-006	---	1.75	H24-004	---	1.50
71-T	Toro	H24-865	---	1.75	---	---	---
71-TA	Gladden Prod.	H24-865	---	1.75	---	---	---
72-A	Muncie	H23-046	2.00	---	H23-049	1.70	---
72-B	Champion	H23-114	2.00	---	H23-049	1.70	---
72-C	Sears	H23-106	2.00	---	H23-049	1.70	---
72-D	Maytag	H23-308	---	1.90	H23-330	---	1.60
72-DA	Maytag	H27-275	---	1.90	H27-277	---	1.60
72-E	Muncie	H24-842	---	1.75	H24-004	---	1.50
72-F	Muncie	H24-852	---	1.75	H24-856	---	1.50
72-H	Western Auto-Kiekhaefer	H24-873	---	1.75	H24-004	---	1.50
72-J	Sears	H24-913	---	1.90	H24-929	---	1.60
82-D	Muncie	H21-824	1.75	---	H21-759	1.55	---
82-DA	Cross Gear	H21-882	1.75	---	H21-759	1.55	---
82-D, DA	Muncie	H21-824	---	1.75	H21-759	---	1.55
82-F	Muncie	H21-824	---	1.75	H21-759	---	1.55
	Eisemann	H27-894-L-P	1.9	---	---	---	---

NOTE: Coils such as the H27-894 can only be tested in assembly with the laminated core or complete stator assembly.

EISEMANN CONDENSER

Part No.	Capacity Microfarad
24235	.19 - .23

EISEMANN MAGNETOS COILS

Part No.	Model Used on or Type	Operating Amperage	Secondary Continuity Min. Max.
H27-958	All AM & LA models	1.35	40 - 60
H27-959	All models with H26-958 cam.	1.80	40 - 60
H28-030	RC & RT models	1.25	45 - 65
H27-940	All 51 series except 51F, & FS. 61J, 62A & B	1.9	35 - 55
H24-704	51F & FS	1.9	35 - 55
H27-927	62D	2.2	35 - 55
H27-894	All-61 series except 61J. & 61NA, 71R, RL, RG, S1, S2, S3, T, TA, 72E & H	1.75	35 - 55
H28-015	72A, B, C, (D, DA, & F.)	2.0	40 - 60
H28-015	72D & DA	1.9	40 - 60
H28-015	72F	1.75	40 - 60

EISEMANN MAGNETO CONDENSER

Part No.	Capacity Reading In Microfarads Min. - Max.
H22-91017-.22
H23-47017-.22
H24-23517-.22
H24-92417-.22
H26-98217-.22
H28-09017-.22

FAIRBANKS-MORSE COIL SPECIFICATIONS

Coil No.	Type	Operating Amperage	Primary Resistance		Secondary Continuity	
			Min.	Max.	Min.	Max.
**A2477	RVI	1.55				
*A2477	RVI	2.40				
A2477A	FMJE1	1.60				
A2477C		1.80			35 - 55	
A2480	R2 (Wound Armature)	1.80				
*B2477	RV4-6, DRV	2.10				
B2477A	FJMHE2	1.55				
B2480A	R (Wound Armature)	1.80				
BX2477	FMSC1B70	1.70				
C2477	FM-FMK-FMH-FMO-FMOK-FMOH	1.55				
C2477A	FMJFE2-FMJJE4-FMJG4	1.55				
C2477AX	FMJE4	1.55				
D2477	RSI-FM1B	1.55				
DX2477C		1.25			40 - 60	
E2477	FMJ4A-FMJ4B	1.70			40 - 60	
EX2477C		1.40			40 - 60	
F2477	FMT4B (Battery Ignition with Bridge Laminations)	1.40			40 - 60	
FX2477		1.90			50 - 60	
G2477	FMJ4A-FMJ4B	1.55				
GX2477C		1.70			40 - 60	
H2477	FMJV4-FMJVE4	1.70			40 - 60	
H2477C		1.90			45 - 65	
HX2477		1.90			50 - 60	
J2477	FMOI	1.55				
JX2477		2.00			40 - 60	
K2477	FMO-FMOH	1.55				
L2477	FMJI	1.80			35 - 55	
L2477C		1.80			35 - 55	
L2477X	FMJIA	1.60				
LX2477C		1.50			40 - 60	
M2477	FMJIA2	1.55				
P2477		1.55			40 - 60	
P2477C		1.60			40 - 60	
***Q2477C	Double Secondary Leads	1.70			50 - 70	
Q2477C		1.70			50 - 70	
Q2477CX		1.70			50 - 70	
QP2477C		1.70			50 - 70	
QR2477C		1.70			50 - 70	
Q52477C		1.65			45 - 65	
QT2477C		1.70			45 - 65	
QW2477C		1.70			50 - 70	
QX2477C		1.70			50 - 70	
QY2477C		2.30			45 - 60	
QZ2477C		1.70			50 - 70	
R2477C		1.70			40 - 60	
RS2477C		1.70			40 - 60	
S2477C		1.90			45 - 65	
T2477	FMXV4B70	1.80			40 - 60	
T2477C		1.80			35 - 55	
TX2477		1.5	.62 - .68		45 - 55	
U2477		1.70			50 - 60	
U2477C		1.60			40 - 60	
X2477		1.5	.62 - .68		45 - 55	

*Bakelite Housing Coil. **Tape Wound. ***See page 23, Fig. 26, connect 1-secondary lead with 1-primary lead.

FAIRBANKS-MORSE CONDENSER CAPACITIES SPECIFICATIONS

Condenser No.	Capacity Reading in Microfarads	
	Min.	Max.
AX2433	.17-	.23
AX-M-R2433	.18-	.23
BX2433	.16-	.19
CX2433	.28-	.36
DX2433	.28-	.36
EX2433	.17-	.23
FX2433	.28-	.36
GX2433	.16-	.19
HX2433 Feed Through	.37-	.43
JX2433	.17-	.23
K2433	.16-	.24
KX2433	.28-	.35
LV2433	.38-	.43
M2433	.17-	.23
MX2433	.28-	.35
PX2433	.28-	.35
QX2433	.28-	.35
R2433	.17-	.23
RX2433	.37-	.42
S2433	.28-	.32
SXY2433	.28-	.33
SYX2433X	.28-	.36
TX2433	.28-	.35
WX2433	.28-	.35
X2433	.28-	.36
Y2433	.28-	.36

GALE PRODUCTS - BUCCANEER

Model No.	H.P.	Year	Magneto No.	Coil No.	Operating Amperage	Continuity Min. Max.	Condenser No.	Capacity Microfarads
12D11B	12	1954-55	580153	580416	1.7	30 - 40	580321	.18-.22
12S12B	12	1956	580207	580416	1.7	30 - 40	580321	.18-.22
12D13B	12	1956	580207	580416	1.7	30 - 40	580321	.18-.22
12D14B	12	1956	580207	580416	1.7	30 - 40	580321	.18-.22
12DE13B	12	1956	580207	580416	1.7	30 - 40	580321	.18-.22
12S13B	12	1957	580207	580416	1.7	30 - 40	580321	.18-.22
12S14B	12	1957	580207	580416	1.7	30 - 40	580321	.18-.22
12D15B	12	1957	580207	580416	1.7	30 - 40	580321	.18-.22
12D16B	12	1957	580207	580416	1.7	30 - 40	580321	.18-.22
12DE15B	12	1957	580207	580416	1.7	30 - 40	580321	.18-.22
12S15B	12	1958	580207	580416	1.7	30 - 40	580321	.18-.22
12D17B	12	1958	580254	580416	1.7	30 - 40	580321	.18-.22
12D18B	12	1959	580254	580416	1.7	30 - 40	580321	.18-.22
22D10B	22	1955	580180	580416	1.7	30 - 40	580321	.18-.22
22DE10B	22	1955	580180	580416	1.7	30 - 40	580321	.18-.22
22D12B	22	1955	580180	580416	1.7	30 - 40	580321	.18-.22
22DE12B	22	1955	580180	580416	1.7	30 - 40	580321	.18-.22
22D11B	25	1956	580209	580416	1.7	30 - 40	580321	.18-.22
22DE11B	25	1956	580209	580416	1.7	30 - 40	580321	.18-.22
22D13B	25	1956	580209	580416	1.7	30 - 40	580321	.18-.22
22DE13B	25	1956	580209	580416	1.7	30 - 40	580321	.18-.22
22D14B	25	1957	580209	580416	1.7	30 - 40	580321	.18-.22
22DE14B	25	1957	580209	580416	1.7	30 - 40	580321	.18-.22
22D15B	25	1958	580274	580416	1.7	30 - 40	580321	.18-.22

- GALE PRODUCTS - BUCCANEER (Cont'd)

Model No.	H. P.	Year	Magneto No.	Coil No.	Operating Amperage	Continuity Min.,Max.	Condenser No.	Capacity Microfarads
22DE15B	25	1958	580274	580416	1.7	30 - 40	580321	.18-.22
22D16B	25	1959	580274	580416	1.7	30 - 40	580321	.18-.22
22DE16B	25	1959	580274	580416	1.7	30 - 40	580321	.18-.22
35DE10B	35	1958	580333	580197	1.4	42 - 52	580321	.18-.22
35D11B	35	1959	580333	580197	1.4	42 - 52	580321	.18-.22
35DE11B	35	1959	580333	580197	1.4	42 - 52	580321	.18-.22
35D12B	35	1959	580333	580197	1.4	42 - 52	580321	.18-.22
35DE12B	35	1959	580333	580197	1.4	42 - 52	580321	.18-.22

GALE PRODUCTS - BUCCANEER (Cont'd)

Model No.	H.P.	Year	Magneto No.	Coil No.	Operating Amperage	Continuity No.	Condensor No.	Capacity
3D16	3	1960	580128	580416	1.7	30 - 45	580321	.18-.22
5D17	5	1960	580206	580416	1.7	30 - 45	580321	.18-.22
15D10	15	1960	580270	580197	1.4	42 - 52	580422	.25-.29
25D17	25	1960	580274	580416	1.7	30 - 45	580321	.18-.22
25DE17	25	1960	580274	580416	1.7	30 - 45	580321	.18-.22
35D13	35	1960	580307	580197	1.4	42 - 52	580422	.25-.29
35DE13	35	1960	580307	580197	1.4	42 - 52	580422	.25-.29
60D10	60	1960	580319	580243	1.7	40 - 55	580256	.37-.41
60DE10	60	1960	580319	580243	1.7	40 - 55	580256	.37-.41
3D17	3	1961	580128	580416	1.7	40 - 55	580321	.18-.22
5D18	5	1961	580206	580416	1.7	40 - 55	580321	.18-.22
5D19	5	1961	580206	580416	1.7	40 - 55	580321	.18-.22
5D21	5	1961	580206	580416	1.7	40 - 55	580321	.18-.22
15D11	15	1961	580270	580197	1.4	42 - 52	580422	.25-.29
15D12	15	1961	580270	580197	1.4	42 - 52	580422	.25-.29
25D18	25	1961	580274	580416	1.7	30 - 45	580321	.18-.22
25DE18	25	1961	580274	580416	1.7	30 - 45	580321	.18-.22
25D20	25	1961	580274	580416	1.7	30 - 45	580321	.18-.22
25DE20	25	1961	580274	580416	1.7	30 - 45	580321	.18-.22
40D14	40	1961	580333	580197	1.4	42 - 52	580321	.18-.22
40DE14	40	1961	580333	580197	1.4	42 - 52	580321	.18-.22
60D11	60	1961	580319	580243	1.7	40 - 55	580256	.37-.41
60DE11	60	1961	580319	580243	1.7	40 - 55	580256	.37-.41
60D12	60	1961	580319	580243	1.7	40 - 55	580256	.37-.41
60DE12	60	1961	580319	580243	1.7	40 - 55	580256	.37-.41

GALE PRODUCTS - BUCCANEER (Cont'd)

Model No.	H. P.	Year	Magneto No.	Coil No.	Operating Amperage	Continuity No.	Condensar No.	Capacity
3D18	3	1962	580128	580416	1.7	30 - 45	580321	.18-.22
5D20	5	1962	580206	580416	1.7	30 - 45	580321	.18-.22
15D13	15	1962	580434	580416	1.7	30 - 45	580422	.25-.29
15D14	15	1962	580254	580416	1.7	30 - 45	580321	.18-.22
25D19	25	1962	580274	580416	1.7	30 - 45	580321	.18-.22
25DE19	25	1962	580274	580416	1.7	30 - 45	580321	.18-.22
40D15	40	1962	580415	580416	1.7	30 - 45	580422	.25-.29
40DE15	40	1962	580415	580416	1.7	30 - 45	580422	.25-.29
60DE13	60	1962	580319	580243	1.7	40 - 55	580256	.37-.41
60DG13	60	1962	580319	580243	1.7	40 - 55	580256	.37-.41

GALE PRODUCTS-OMC COIL SPECIFICATIONS

Coil No.	Operating Amperage	Primary Resistance Min. Max.	Secondary Continuity Min. Max.
425371	1.9		38 - 58
425960	2.10		30 - 50
470187- ①	1.8		40 - 55
470187- ②	1.7		50 - 60
470685- ③	1.4	.5 - .7	40 - 55
470685- ④	1.8	.47 - .55	30 - 40
580454	1.4	.4 - .6	30 - 40

CONDENSER SPECIFICATIONS

Condenser No.	Capacity Microfarads Min. Max.
425369	.16 - .20
425373	.16 - .20
425702	.16 - .20
426528	.18 - .22

GAMBLE HIAWATHA

Year	Model No.	HP	Coil Number			Oper. Amp.	Prim. Res. Min. Max.	Sec. Cont. Min. Max.	Condenser No.		Capacity Micro-farads
			Make	Mfg.	Scott				Mfg.	Scott	
1959	143A	7.5	Phelon	FG3689	138-134	2.5		40 - 60	FG3693	138-115	.15-.19
	148A	10	Phelon	FG3689	138-134	2.5		40 - 60	FG3693	138-115	.15-.19
	145A	25	McC		736-232	1.6		43 - 55	FG3478	1436-115	.18-.22
	345A	25	McC		736-232	1.6		43 - 55	FG3478	1436-115	.18-.22
	346A	40	McC		736-232	1.6		43 - 55	FG3478	1436-115	.18-.22
1960	A4BB	3.6	Phelon	FG3689	138-134	2.5		40 - 60	FG3693	138-115	.15-.19
	A4EB	7.5	McC		134-134	1.9		30 - 45	X12293	134-115	.18-.22
					234-134						
	C4EB	7.5	McC		134-134	1.9		30 - 45	X12293	134-115	.18-.22
					234-134						
	A4FB	12	Phelon	FG4128	139-134	2.5		40 - 60	FG3693	138-115	.15-.19
	A4GB	25	Wico	X11352	3685-113	2.0		40 - 60	X11362	3685-115	.26-.30
	C4GB	25	McC		436B-134	1.4		40 - 60	X12264	335B-115	.26-.30
	D4GB	25	McC		436B-134	1.4		40 - 60	X12264	335B-115	.26-.30
					336B-134						
C4HB	40	McC		436B-134	1.4		40 - 60	X12264	335B-115	.26-.30	
				336B-134							
D4HB	40	McC		436B-134	1.4		40 - 60	X12264	335B-115	.26-.30	
C4JB	60	McC		C3JB-134	1.4	.55-.85	45 - 55	X12265	332B-115	.26-.30	
D4JB	60	McC		C3JB-134	1.4	.55-.85	45 - 55	X12264	332B-115	.26-.30	
1961	61400310	3.6	Phelon	FG3689	138-134	2.5		40 - 60	FG3693	138-115	.15-.19

GOODYEAR'S - "SEA BEE"

Model No.	H. P.	Year	Magneto No.	Coil No.	Operating Amperage	Continuity Min. Max.	Condenser No.	Capacity Microfarads
025-3574	3	1954-55	580128	580118	1.6	30 - 40	510173	.18-.22
025-3574 (3D12G)	3	1955	580128	580118	1.6	30 - 40	510173	.18-.22
225-3606 (3D13G)	3	1956	580128	580118	1.6	30 - 40	510173	.18-.22
225-3612 (3D14G)	3	1957	580128	580118	1.6	30 - 40	510173	.18-.22
225-3619 (3619)	3	1958-59	580128	580118	1.6	30 - 40	510173	.18-.22
025-3602 (5S11G)	5	1955	580120	580118	1.6	30 - 40	510173	.18-.22
025-3603 (5D11G)	5	1955	580183	580118	1.6	30 - 40	510173	.18-.22
225-3607 (5S12G)	5	1956	580120	580118	1.6	30 - 40	510173	.18-.22
225-3608 (5D12G)	5	1956	580182	580118	1.6	30 - 40	510173	.18-.22
225-3608 (5D13G)	5	1956	580182	580118	1.6	30 - 40	510173	.18-.22
225-3613 (5S13G)	5	1957	580120	580118	1.6	30 - 40	510173	.18-.22
225-3614 (5D14G)	5	1957	580182	580118	1.6	30 - 40	510173	.18-.22
225-3620	5	1958	580120	580118	1.6	30 - 40	510173	.18-.22
225-3621	5	1958	580206	580118	1.6	30 - 40	510173	.18-.22
225-3450	5	1959	580206	580118	1.6	30 - 40	510173	.18-.22
25-3572	12	1954-55	580153	580118	1.6	30 - 40	510173	.18-.22
225-3609 (12D13G)	12	1956	580207	580118	1.6	30 - 40	510173	.18-.22
225-3609 (12D14G)	12	1956	580207	580118	1.6	30 - 40	510173	.18-.22
225-3615 (12D15G)	12	1957	580207	580118	1.6	30 - 40	510173	.18-.22
225-3615 (12D16G)	12	1957	580207	580118	1.6	30 - 40	510173	.18-.22
226-3622	12	1958	580254	580118	1.6	30 - 40	510173	.18-.22
225-3451	12	1959	580254	580118	1.6	30 - 40	510173	.18-.22
25-3604 (22D10G)	22	1955	580180	580118	1.6	30 - 40	510173	.18-.22
25-3605 (22DE10G)	22	1955	580180	580118	1.6	30 - 40	510173	.18-.22
25-3604 (22E12G)	22	1955	580180	580118	1.6	30 - 40	510173	.18-.22
25-3605 (22DE12G)	22	1955	580180	580118	1.6	30 - 40	510173	.18-.22
225-3610 (22D11G)	25	1956	580209	580118	1.6	30 - 40	510173	.18-.22
225-3610 (22D13G)	25	1956	580209	580118	1.6	30 - 40	510173	.18-.22
225-3611 (22DE11G)	25	1956	580209	580118	1.6	30 - 40	510173	.18-.22
225-3611 (22DE13G)	25	1956	580209	580118	1.6	30 - 40	510173	.18-.22
225-3616 (22D14G)	25	1957	580209	580118	1.6	30 - 40	510173	.18-.22

GOODYEAR'S - "SEA BEE" (Cont'd)

Model No.	H. P.	Year	Magneto No.	Coil No.	Operating Amperage	Continuity Min. Max.	Condenser No.	Capacity Microfarads
225-3617 (22DE14G)	25	1957	580209	580118	1.6	30 - 40	510173	.18- .22
225-3623	25	1958	580274	580118	1.6	30 - 40	510173	.18- .22
225-3624	25	1958	580274	580118	1.6	30 - 40	510173	.18- .22
225-3452	25	1959	580274	580118	1.6	30 - 40	510173	.18- .22
225-3453	25	1959	580274	580118	1.6	30 - 40	510173	.18- .22
225-3454	35	1959	580275	580197	1.4	42 - 52	510173	.18- .22
225-3455	35	1959	580275	580197	1.4	42 - 52	510173	.18- .22
225-3454A	35	1959	580275	580197	1.4	42 - 52	510173	.18- .22
225-3455A	35	1959	580275	580197	1.4	42 - 52	510173	.18- .22

84

HOMELITE COIL SPECIFICATIONS

Coil No.	Mfg.	Mfg. No.	Operating Amperage	Secondary Continuity Min. Max.	Fits Homelite Models
	Wico	X16669	1.3	50 - 60	XL850
	Wico	X16797	1.8	50 - 60	FWK-2868
	Wico	X16809	1.3	50 - 60	Pump Model 257
55232	Phelon	FG1618	2.8	40 - 60	Old 17
55403	Wico	X9533	2.2	30 - 50	17, 5-20
58874	Wico	X14171	2.1	30 - 50	XL Series
59860	Phelon	FG7049	2.8	61 - 71	XL Series
63625	Wico	X16343	1.3	50 - 60	XL700 & 800
72397	Wico	X7536	1.9	38 - 58	26, 5-30, 7-29

HOMELITE CONDENSER SPECIFICATIONS

Condenser No.	Capacity Reading in Microfarads Min. Max.	Fits Homelite Models
55233	.15- .19	Old 17
55399	.16- .20	17, 5-20
55987	.18- .22	C-Series, others
58817 approx.	.17- .21	XL Series
59862 approx.	.21- .25	XL Series
63626	.16- .20	XL700 & 800
72396	.30- .34	26, 5-30, 7-29

HONDA

Model No.	Coil No.	Oper. Amps	Primary Resistance Min. Max.	Secondary Continuity Min. Max.
C100/C110	100-1801.3FND	1.7	.5- .6	35 - 45
C102	C102-1806ND	1.15	1.4- 1.6	55 - 65
C200/CT200 C100C110	C2004806AK	1.15	1.1- 1.3	65 - 75
C105T Energy Transformer	C110-4806ND	.5	4.4- 4.6	55 - 65
CB160	CB93-4806ND	.52	3.8- 4.3	55 - 65
CB72, CB77 CL72	CB721806A-ND	.60	3.8- 4.2	50 - 60
C100/C110 C105T	C100, 1801, 3KND	Resistance only Min. 1.4 Max. 1.6		

All Condensers are rated at Min. .21 and Max. 25.

NOTE: When testing Coil (C110-4806AK) disconnect the Internal Battery and connect Analyzer Leads to a 12 volt storage battery attaching our part no. 55-174 Suppressor in series with one side of the Battery Lead. Do not use the 12 volts for any other tests.

INTERNATIONAL HARVESTER COIL SPECIFICATIONS

Coil No.	Type	Operating Amperage
E4329A	E4A-E4B-E4C	1.20
21401D	F4 (With Core)	2.10
21401D	F6 (With Core)	2.10
.	H1-H4	2.10

JOHN DEERE TRACTOR WORKS

Coil No.	Mfg.	Operating Amperage	Primary Resistance Min. Max.	Secondary Continuity Min. Max.
AM31036	Delco #1115043	.55	3.5- 4.5	39 - 48
John Deere Model #VH60	Lauson 30560	1.5	.46- .56	50 - 60

OMC-EVINRUDE & JOHNSON MAGNETO
& BATTERY COIL SPECIFICATIONS

Coil No.	Type	Operating Amperage	Primary Resistance		Secondary Continuity	
			Min.	Max.	Min.	Max.
72-110	Old A25	2.30				
72-582	A25 to 50, AZ35 to 45	2.40			30 - 60	
72-641	P30-P35-P45-TR40-P40	2.00			45 - 65	
72-669	K35-K40-K45	2.40			30 - 60	
72-749	F1036	1.90				
72-792	A25 to 50, AZ35 to 45	2.10			30 - 60	
72-808	S45-550-SR50-SR55	2.20				
72-813	V45 & up 4 cyl. 2 coils	2.40			30 - 60	
72-851	XR55-OK55-60-P50	0.60			65 - 80	
72-852	5V & 1/4-50 & up, all models	1.00			65 - 80	
72-875	A50 & up, K50 & up	1.70			50 - 65	
72-947	F70-F75-OA55-OA60-OB	2.00			30 - 60	
72-1005	300-36 Twin	2.60			30 - 60	
72-1017	Iron Horse	2.40				
72-1018	Iron Horse (All Models)	1.27			30 - 60	
72-1045	LT37-LS37-DT37-DS37	2.40				
72-1072	LT, LD, & AT-37 & up	2.31			30 - 60	
275-370		1.80			50 - 65	
275-540		1.50			65 - 80	
276-039		1.80			50 - 65	
375-102	SD-10-1940	1.00			50 - 65	
***375-189	TS, TD, HS, HD, MS, MD & Later	1.5	.375-	.575	30 - 45	
378-231		.8	1.5	-1.8	60 - 70	
378-665	- Resistance on Electromatic Johnson Forward or Reverse - 7.0-8.0 ohms					
379-519	- Model No. SU & HU - Resistance Min. - 5.0 Max. - 6.0					
379-569		.8	1.5	-1.65	60 - 70	
*381-886		1.3	.12	-.16	8 - 10	
*560-688		1.3			16 - 22	
580-040		1.60			30 - 40	
580-084		1.60			34 - 46	
580-118		1.60	.4	-.6	40 - 50	
580-197*		1.5	.5	-.6	45 - 55	
580-243	50 HP	1.5	.4	-.55	40 - 55	
580-380		1.0	.7	-.8	70 - 80	
580-416		1.7	.4	-.55	35 - 45	
580-527		1.0	.7	-.8	70 - 80	
**580-527	(With Loose Pig-Tail Leads)	.6	.7	-.9	65 - 75	
****580-602		.6	.7	-.9	65 - 75	
	Leads Attached with Black or Purple Cement.					
****580-602		.6	2.5	-3.0	70 - 80	
	Leads Attached with Dark Purple Cement. Most Engines are using this Coil					

*To check Coil use C.D. Adaptor #55-980 beginning with Serial No. 325.

**Disconnect Internal battery and connect lead to a 12 volt storage battery or equal and connect our part no. 55-174 Suppressor in series with one lead. NOTE: DO NOT USE THE FULL 12 VOLTS ON THIS COIL.

***Coils #375-189 with 2-secondary and 2-primary leads, connect 1-secondary lead to 1-primary lead then attach tester leads as shown in figure 26, page 23.

****Disconnect Internal Battery and connect leads from analyzer to a 12 volt Storage Battery or equal. This test is for COIL POWER TEST only. DO NOT USE THE 12 VOLTS FOR ANY OTHER TESTS AS READING WILL BE INCORRECT.

**OMC-EVINRUDE & JOHNSON MAGNETO
& BATTERY CONDENSER SPECIFICATIONS**

Condenser No.	Capacity Reading in Microfarads	
	Min.	Max.
72-864	.27-	.33
72-873	.20-	.24
170-002 - Use 172-470	.27-	.36
170-067 - Use 171-449	.09-	.125
171-311 - Use 171-471	.18-	.25
171-448	.09-	.125
171-449	.09-	.125
171-470	.27-	.36
171-471	.18-	.26
201-484	.16-	.24
201-753	.16-	.24
300-153	.15-	.205
510-173	.18-	.22
580-256	.37-	.41
580-321	.18-	.22
580-422	.25-	.29
580-573	.18-	.22

KIEKHAEFER-MERCURY COIL SPECIFICATIONS

Coil No.	Mfg.	Mfg. No.	Oper. Amps	Primary Resistance		Secondary
				Min.	Max.	Continuity
26433	Kiekhæfer	Delco-Remy	.9	.9-	1.2	55 - 65
30-204	Scintilla	10-38222Y	2.30			40 - 60
32193	Autolite	200673	1.1	1.2-	1.4	60 - 70
32704	(Note: With Internal Resistance)		.5	3.9-	4.3	48 - 58
38547			.5	3.9-	4.8	48 - 58
*282-682			1.9			6 - 8
298-2568			1.8	4.5-	5.5	40 - 60
*332-2983A	(with steel frame)		2.0			8 - 10
**394-1128	Kiekhæfer		1.8			55 - 65
**394-1128A1	Kiekhæfer	394-1128	1.8			55 - 65
395-679	Wico	X-2156	1.5			30 - 50
396-648	Eisemann	27B94	1.6			40 - 60
397-361	Fairbanks	H-2477, E-2477C-T-2477	2.0			40 - 60
397-430	Fairbanks	QY-2477C	2.0			45 - 60
398-173	Phelon	F-1835	2.5			40 - 65
398-716	Phelon	F-608	2.5			40 - 65
398-2201	Phelon	FG-6446	2.0	.45-	.60	45 - 60
398-2545			2.0	4.5-	5.5	35 - 45
399-125	Scintilla	10-70132	2.10			30 - 50
399-756	Scintilla	10-70100	2.10			30 - 50
**399-1246	Scintilla	10-111280	1.5			30 - 42

*To Check these coils use C.D. Adaptor #55-980 beginning with Serial No. 325.

**OFF Plate

KIEKHAEFER-MERCURY CONDENSER SPECIFICATIONS

Condenser No.	Mfg.	Mfg. No.	Capacity Reading in Microfarads	
			Min.	Max.
33662			.18-	.25
33706			.18-	.25
37189			.24-	.30
393-1283	Delco-Remy		.18-	.23
394-1130	Kiekhæfer	394-1130	.28-	.35
395-684	Wico	X-2186	.16-	.20
396-650	Eisemann	24235	.19-	.23
397-359	Fairbanks	M 2433	.18-	.22
397-741	Fairbanks	"5"	.28-	.32
397-874	Fairbanks	KX 2433	.28-	.35
398-176	Phelon	FG-1807	.22-	.27
398-693	Phelon	FG-1770	.14-	.18
398-713	Phelon	FG-607	.15-	.19
398-2203	Phelon	FG-6453	.14-	.20
*399-123	Scintilla	10-82238	.15-	.21
399-759	Scintilla	10-70141	.17-	.21

KIEKHAEFER-MERCURY RESISTOR TEST

Mfg. & Part No.	Resistance Reading
	Min. Max.
Kiekhæfer - 393-1286	1.3- 1.7
Kiekhæfer - 393-1482	2.0- 2.4
Kiekhæfer - 393-1572	3.0- 3.4
Kiekhæfer - 32227 Autolite - 200673 (Mfg. & No.)	.410-.520

KOHLER COMPANY COIL AND CONDENSER SPECIFICATIONS

Coil No.	Engine Model	Mfg.	Mfg. No.	Operating Amperage	Secondary Continuity Min. Max.	Condenser #	Capacity Reading in Microfarads Min. Max.
S410				1.60			
220435	K91	Phelon	FG2145	2.8	40 - 60	220434 Phelon FG2138	.12 - .16
230075	K161	Scintilla	10-160396	1.8	30 - 40	220082 Scintilla 10-79168Y	.18 - .23
A-231340		Delco	1115043	.55	39 - 48	230722 Delco 1965489	.27 - .31
270560	K662	Wico	X12810	1.7	60 - 75	270541 Wico X6916	.30 - .34
270775	K662	Fairbanks	Q3477C	1.7	50 - 70	270779 Fairbanks SYX2433X	.28 - .36
271144	K662	Wico	X5700C	1.7	40 - 60	270607 Wico X5614	.16 - .20
275756	K241 & K33	Phelon	FG1641	2.2	50 - 70	220434 Phelon FG2138	.12 - .16

LAUSON POWER PRODUCTS COIL SPECIFICATIONS

Coil No.	Mfg. Model #	Mfg. No.	Operating Amperage	Primary Resistance Min, Max.	Secondary Continuity Min, Max.
22094	Wico	X2156	1.50		30 - 50
23084	Wico	X-4943	1.50		35 - 55
24439	Phelon	FG-463	2.8		40 - 60
25527	Wico	X-7467	1.80		30 - 50
25811	Fairbanks-Morse	A-2477A	1.60		
26318	Fairbanks-Morse	T-2477A	1.80		35 - 55
26624	Fairbanks-Morse	FX-2477	1.90		50 - 60
26714	Wico	X-8795	1.80		30 - 50
26787	Fairbanks-Morse	HX-2477	1.90		50 - 60
26935	Wico	X-8786	1.80		
27089	Wico	X-9055	2.10		35 - 55
27089	Wico	X-9695 RAP with X-11180	1.80		40 - 50
27376	Wico	X-11205	2.0		40 - 55
27531	Wico	X-9965	1.8		40 - 55
28259	Wico	X-11654	2.1		40 - 55
29176	Phelon	FG-3294	2.8		40 - 60
29176	Phelon	FG-4081	2.8		40 - 60
29632	Lauson	5022 (Syncro)	2.3	.5- 1.5	40 - 55
30560	Lauson VH60 John Deere (Replaces 30546)	5160 (Syncro)	1.6	.45-.55	50 - 60
32014	Lauson HH80	8	1.4	.37- .45	55 - 65
32014	Lauson HH100	10	1.4	.37- .45	55 - 65
32014	Lauson HH120	12	1.4	.37- .45	55 - 65
610197	Eiseman	H27-940	1.9		35 - 55
610215	Fairbanks-Morse	U-2477	1.70		50 - 60
610242	Phelon	FG-114	2.5		40 - 60
610277	Phelon	FG-307	2.5		40 - 60
610286	Phelon	FG-420	2.8		40 - 60
610287	Phelon	FG-420B	2.8		40 - 60
610287	Phelon	FG-1573B	2.8		40 - 60
610292	Phelon	FG-470	2.8		40 - 60
610293	Phelon	FG-470B	2.8		40 - 60
610298	Phelon	FG-492B	2.5		40 - 60
610323	Phelon	FG-1309	2.8		40 - 60
610355	Wico	X-8877	2.0		
610355	Wico	X-9767	1.80		35 - 55
610371	Phelon	FG-2180	2.8		40 - 60
610371	Phelon	FG-2446	2.8		40 - 60
610415	Wico	X-7500	2.10		30 - 50
610425	Wico	X-5345	1.50		40 - 60
610466	Phelon	FG-2641	2.8		40 - 60
610477	Phelon	FG-2180B	2.8		40 - 60
610482	Phelon	FG-2641B	2.8		40 - 60
610586	Phelon	FG-4055	2.8		50 - 70
610657	Phelon	FG-6335	1.4	.85- .95	50 - 60
610706	Lauson		1.8	.59- .65	55 - 65

LAUSON POWER PRODUCTS CONDENSER SPECIFICATIONS

Condenser No.	Mfg.	Mfg. No.	Capacity Reading in Microfarads	
			Min.	Max.
22095	Wico	X-2186	.16-	.20
23359	Wico	X-5800	.16-	.20
24445	Phelon	FG-458	.12-	.16
25809	Fairbanks-Morse	R-2433	.17-	.23
26219	Wico	X-5614	.16-	.20
26641	Phelon	FG-458B	.12-	.16
26718	Wico	X-9100	.26-	.30
26786	Fairbanks-Morse	GX-2433	.16-	.19
27527	Wico	X-11000	.16-	.23
29164	Wico	X-12174	.16-	.20
29172	Phelon	FG-4082	.15-	.19
29177			.15-	.19
29559	Wico	X-11672	.16-	.20
29559	Wico	X-12513	.16-	.20
30548			.12-	.14
30548-A			.16-	.18
32015			.24-	.27
610253	Phelon	FG-159	.15-	.19
610268	Phelon	FG-216	.15-	.19
610269	Phelon	FG-216B	.15-	.19
610294	Phelon	FG-471	.12-	.16
610294	Phelon	FG-471B	.12-	.16
610303	Phelon	FG-607	.15-	.19
610303	Phelon	FG-1205	.35-	.38
610331	Phelon	FG-1355	.12-	.16
610370	Phelon	FG-2176	.15-	.19
610424	Wico	X-5342	.30-	.34
610438	Wico	X-5463	.16-	.20
610447	Fairbanks-Morse	BX-2433	.16-	.19
610467	Phelon	FG-2642	.12-	.16
610588	Phelon	FG-4016	.18-	.22
610707			.19-	.21

LAWNBOY COIL AND CONDENSER SPECIFICATIONS

Coil No.	Operating Amperage	Primary Resistance		Secondary Continuity		Condenser No.	Capacity Reading in Microfarads	
		Min.	Max.	Min.	Max.		Min.	Max.
580-118	1.60			30 -	40	510173	.13-	.17
580-184	1.60			30 -	40	677299	.13-	.17
678-111	1.60			30 -	40			
678-539	1.5	.48-	.56	35 -	45			

MALLORY ELECTRIC CORPORATION COIL SPECIFICATIONS

Color Code & Coil No.	Operating Amperage	Primary Resistance	Ballist Resistance	Secondary Continulty Min. Max.
Green 6V-6000	.9	.4-.6	.3-.6	55 - 70
Blue 12V-12000	.9	1.1-1.4	.7-1.0	55 - 70
Black F-6	.9	.6-.8	.35-.6	55 - 65
Red F-12	.8	2.1-2.4	.7-.9	55 - 65
Black 12V-258288	1.1	1.5-1.9	.35-.55	50 - 65
Red 25773	1.0	1.9-2.3		50 - 65
Brown 25742	1.25	.8-1.2		52 - 62

THIS TEST FOR MODEL 88 ONLY

Color Code & Coil No.	Operating Amperate	Primary Resistance	Resistance Between P & R	Ballist Resistance	Secondary Continulty Min. Max.
MS6VP	P-Side .4	.5-.7	1.1-1.3	R-.45-.55	65 - 75
MS6VP	R-Side .6	.4-.6		R-.45-.55	
MS6VN	P-Side .4	.5-.7	1.1-1.3	P-.45-.55	65 - 75
MS6VN	R-Side .6	.5-.7		R-.45-.55	
MS12VN	P-Side .3	1.5-1.8	2.5-2.8	.9-1.2	60 - 70
MS12VN	R-Side .5	.95-1.25		.9-1.2	
MS12VP	P-Side .3	2.0-3.5	4.0-5.0	.9-1.2	60 - 70
MS12VP	R-Side .5	1.0-3.0		.9-1.2	

NOTE THIS TEST FOR MODEL 60 ONLY

MS6VP	2.9	65 - 75
MS6VN	2.5	65 - 75
MS12VN	1.9	65 - 75
MS12VP	1.9	65 - 75

MALLORY ELECTRIC CORPORATION CONDENSER SPECIFICATIONS

Condenser Number	Capacity Reading In Microfarads
24125	.34-.38
24895	.34-.38
25010	.34-.38
25500	.26-.30
25600	.26-.30

McCULLOCH CORP. OUTBOARD MOTOR SPECIFICATIONS

Year	Engine Model No.	Kind	HP	Stator Assy. No.	Make Mfg.	Coil No.	Operat. Amp.	Secondary Continuity Min. Max.	Condenser No.	Capacity Microfarads
1955	1055		3.6	FG-1632	Phelon	FG-1573G	2.80	40 - 60	FG-471B	.12 - .16
1955	3055			FG-1632	Phelon	FG-1573G	2.80	40 - 60	FG-471B	.12 - .16
1955	1755		5.7		Wico	X-7467	1.80	30 - 50	X-9182	.26 - .30
1955	1355		7.5	FG-1629	Phelon	FG-1573C	2.80	40 - 60	FG-471B	.12 - .16
1955	2355			FG-1629	Phelon	FG-1573C	2.80	40 - 60	FG-471B	.12 - .16
1955	1855		10		Wico	X-7467	1.80	30 - 50	X-9182	.26 - .30
1955	2855				Wico	X-7467	1.80	30 - 50	X-9182	.26 - .30
1955	1955		16	X-8726	Wico	X-7345	1.70	35 - 55	X-9182	.26 - .30
1955	3655	Std. P. S.		FG-2118	Phelon	FG-2331	2.90	40 - 60	FG-2111	.12 - .16
1956	1665	F	33	FG-2552	Phelon	FG-2546	2.50	40 - 60	FG-2111	.12 - .16
1956	1665-3	F(EL)	33	FG-2552	Phelon	FG-2546	2.50	40 - 60	FG-2111	.12 - .16
1956	2665	C	33	FG-2552	Phelon	FG-2546	2.50	40 - 60	FG-2111	.12 - .16
1956	2665-3	C(EL)	33	FG-2552	Phelon	FG-2546	2.50	40 - 60	FG-2111	.12 - .16
1956	3665	SA	33	FG-2552	Phelon	FG-2546	2.50	40 - 60	FG-2111	.12 - .16

McCULLOCH CORP. OUTBOARD MOTOR SPECIFICATIONS (Cont'd)

Year	Engine Model No.	Kind	HP	Stator Assy. No.	Make Mfg.	Coil No.	Operat. Amp	Secondary Continuity Min. Max.	Condenser No.	Capacity Microfarads
1956	3665-2	SA(LC)	33	FG-2552	Phelon	FG-2546	2.50	40 - 60	FG-2111	.12 - .16
1956	3665-3	SA(EL)	33	FG-2552	Phelon	FG-2546	2.50	40 - 60	FG-2111	.12 - .16
1956	3665-4	SA(EL)	33	FG-2552	Phelon	FG-2546	2.50	40 - 60	FG-2111	.12 - .16
1956	4665	G	33	FG-2552	Phelon	FG-2546	2.50	40 - 60	FG-2111	.12 - .16
1956	4665-3	G(EL)	33	FG-2552	Phelon	FG-2546	2.50	40 - 60	FG-2111	.12 - .16
1957	1075	F.	3.6	FG-1632	Phelon	FG-1573	2.80	40 - 60	FG-471B	.12 - .16
1957	1775	F.	5		Wico	X-7467	1.80	30 - 50	X-9182	.26 - .30
1957	1875	F.	10		Wico	X-7467	1.80	30 - 50	X-9182	.26 - .30
1957	1975	F.	16	X-8726	Wico	X-7345	1.70	35 - 55	X-5463	.16 - .20
1957	1675	F.	35	FG-2550	Phelon	FG-2546	2.50	40 - 60	FG-2111	.12 - .16
1957	1316	F.	35E.	FG-2550	Phelon	FG-2546	2.50	40 - 60	FG-2111	.12 - .16
1957	3075	S. A.	3.6	FG-1632	Phelon	FG-1573	2.80	40 - 60	FG-471B	.12 - .16
1957	3775	SA	5		Wico	X-7467	1.80	30 - 50	X-9182	.26 - .30
1957	3375	S. A.	7.5	FG-1629	Phelon	FG-1573C	2.80	40 - 60	FG-471B	.12 - .16
1957	3875	S. A.	10		Wico	X-7467	1.80	30 - 50	X-9182	.26 - .30
1957	3975	S. A.	16	X-8726	Wico	X-7345	1.70	35 - 55	X-5463	.16 - .20
1957	339	S. A.	16E.	X-9763	Wico	X-7345	1.70	35 - 55	X-5463	.16 - .20
1957	3675	S. A.	40	FG-2903	Phelon	FG-2546	2.50	40 - 60	FG-2727	.18 - .22
1957	336	S. A.	40E.	FG-2902	Phelon	FG-2723	2.80	40 - 60	FG-2727	.18 - .22
1957	536	S. A.	Royal	FG-2902	Phelon	FG-2723	2.80	40 - 60	FG-2727	.18 - .22
1957	4075	Hia.	3.6	FG-1632	Phelon	FG-1573	2.80	40 - 60	FG-471B	.12 - .16
1957	4775	Hia.	5		Wico	X-7467	1.80	30 - 50	X-9182	.26 - .30
1957	4375	Hia.	7.5	FG-1629	Phelon	FG-1573C	2.80	40 - 60	FG-471B	.12 - .16
1957	4975	Hia.	16	X-8726	Wico	X-7345	1.70	40 - 60	X-5463	.16 - .20
1957	4675	Hia.	38	FG-2550	Phelon	FG-2546	2.80	40 - 60	FG-2111	.12 - .16

McCULLOCH CORP. OUTBOARD MOTOR SPECIFICATIONS (Cont'd)

Year	Eng. No.	Make	HP	Stator Assy. No.		Mfg. Make	Coil No.		Oper. Amp.	Secondary Continuity Min. Max.	Generator Coil No.		Condenser No.		Capacity Microfarads
				Mfg.	Scott		Mfg.	Scott			Mfg.	Scott	Mfg.	Scott	
1958	135	Scott Manual	22	X11383	135-101	Wico	X11352	3685-113	2.2	37 - 57			X11362	3685-115	.26 - .30
1958	335	Scott	22	X11345	335-101	Wico	X11352	3685-113	2.2	37 - 57	X11353	335-113	X11362	3685-115	.26 - .30
1958	332	Scott	60		332-101	Phelon	FG3437	332-113	1.0	55 - 75			FG3044	332-115	.24 - .28
1958															

McCULLOCH CORP. OUTBOARD MOTOR SPECIFICATIONS (Cont'd)

96

Year	Eng. No.	Make	HP	Stator Assy. No.		Mfg. Make	Coil Number		Oper. Amp.	Secondary Continuity Min. Max.	Gen. Coil No.		Condenser No.		Capacity Micro-farads	
				Mfg.	Scott		Mfg.	Scott			Mfg.	Scott	Mfg.	Scott		
1958	3085	Scott	3.6	X11445	3085-101	Wico	X11477	3885-113	2.00	40	60			X11397	3885-115	.16-.20
1958	3785	Scott	5	X9066	3845-101	Wico	X7467	3845-113	1.80	30	50			X9182	3745-115	.26-.30
	3785	Scott	5	X5118	3785-101	Wico	X11477	3885-113	2.00	40	60			X11397	3885-115	.16-.20
1958	3385	Scott	7.5	FG1629	1355-101	Phel	FG1573C	1355-134	2.8	40	60			FG471B	5010-115	.12-.16
	3385	Scott	7.5	X11391	3885-101	Wico	X11477	3885-113	2.00	40	60			X11397	3885-115	.16-.20
1958	3885	Scott	10	X11391	3885-101	Wico	X11477	3885-113	2.00	40	60			X11397	3885-115	.16-.20
1958	3985	Scott	16	X8726	3925-101	Wico	X7345	509-113	1.70	35	55			X9182	3745-115	.26-.30
1958	135	Scott	22	X11383	135-101	Wico	X11352	3685-113	2.00	40	60			X11362	3685-115	.26-.30
	335	Scott	22E	X11345	335-101	Wico	X11352	3685-113	2.00	40	60	X11353	335-113	X11362	3685-115	.26-.30
1958	3685	Scott	40	FG2852	3675-101	Phel	FG2546	3665-134	2.5	40	60			FG2727	3675-115	.18-.22
	3685	Scott	40	X11537	3685-101	Wico	X11352	3685-113	2.00	40	60			X11362	3685-115	.26-.30
	3685	Scott	40E	FG2687	336-101	Phel	FG2546	3665-134	2.5	40	60	FG2725	326-134	FG2727	3675-115	.18-.22
	-3											FG2723	336-134			
	3685	Scott	40E	FG3232	1336-101	Phel	FG3375	3665-134	2.8	35	55	FG2725	326-134	FG2727	3675-115	.18-.22
	-3											FG2723	336-134			
1958	3685	Scott	40E	FG3475	1436-101	Phel	FG3375	3665-134	2.8	35	55	FG3476	536-134	FG3478	636-115	.18-.22
	-3										FG3477	636-134				
	1536	Scott	40	FG3232B	1536-101	Phel	FG3375	3665-134	2.8	35	55	FG2725	326-134	FG2727	3675-115	.18-.22
R.S.											FG2723	336-134				
1958	332	Scott	60		332-101	Phel	FG3437	332-113	1.0	55	75			FG3044	332-115	.24-.28
1959	130A	Scott	3.6	X11445	3085-101	Wico	X11477	3885-113	2.00	40	60			X11397	3885-115	.16-.20

McCULLOCH CORP. OUTBOARD MOTOR SPECIFICATIONS (Cont'd)

Year	Eng. No.	Make	HP	Stator Assy. No.		Mfg. Make	Coil Number		Oper. Amp.	Secondary Continuity		Gen. Coil No.		Condenser No.		Capacity Microfarads		
				Mfg.	Scott		Mfg.	Scott		Min.	Max.	Mfg.	Scott	Mfg.	Scott			
1959	137A	Scott	5	X5118	3785-101	Wico	X11477	3885-113	2.00	40	60			X11397	3885-115	.16-.20		
	137A	Scott	5	X9066	3845-101	Wico	X7467	3845-113	1.80	30	50			X9182	3745-115	.26-.30		
	137A	Scott	5	FG3712	137-101	Phel	FG3689	138-134	2.5	40	60			FG3693	138-115	.15-.19		
1959	133A	Scott	7.5	FG3714	138-101	Phel	FG3689	138-134	2.5	40	60			FG3693	138-115	.15-.19		
1959	138A	Scott	10	X9066	3845-101	Wico	X7467	3845-113	1.80	30	50			X9182	3745-115	.26-.30		
	138A	Scott	10	FG3714	138-101	Phel	FG3689	138-134	2.5	40	60			FG3693	138-115	.15-.19		
1959	135A	Scott	25	X11976B	735-101	Wico	X11352	3685-113	2.00	40	60			X11362	3685-115	.26-.30		
	135A	Scott	25	FG3800	535-101	Phel	FG3755	436-134	2.5	40	60			FG3478	1436-115	.18-.22		
	135A	Scott	25	FG3800	535-101	McCulloch	736-232	736-232	1.6	43	55			FG3478	1436-115	.18-.22		
	335A	Scott	25E	FG3799	635-101	Phel	FG3755	436-134	2.5	40	60	FG3809	535-134	FG3478	1436-115	.18-.22		
	335A	Scott	25E	FG3799	635-101	McCulloch	736-232	736-232	1.6	43	55	FG3810	635-134	FG3478	1436-115	.18-.22		
	335A	Scott	25E	W11983B	435-101	Wico	X11352	3685-113	2.00	40	60	FG3809	535-134	FG3478	1436-115	.18-.22		
	335A	Scott	25E	W11983B	435-101	Wico	X11352	3685-113	2.00	40	60	FG3810	635-134	X11353	335-113	X11362	3685-115	.26-.30
1959	136A	Scott	40	X11987B	136-101	Wico	X11352	3685-113	2.00	40	60			X11362	3685-115	.26-.30		
	136A	Scott	40	FG3770	236-101	Phel	FG3755	436-134	2.5	40	60			FG3478	1436-115	.18-.22		
	136A	Scott	40	FG3770	236-101	McCulloch	736-232	736-232	1.6	43	55			FG3478	1436-115	.18-.22		
	336A	Scott	40E	FG3624	436-101	Phel	FG3375	3665-134	2.8	35	55	FG3476	1336-134	FG3478	1436-115	.18-.22		
	336A	Scott	40E	FG3752	836-101	Phel	FG3755	436-134	2.5	40	60	FG3477	1436-134	FG3478	1436-115	.18-.22		
	336A	Scott	40E	FG3752	836-101	McCulloch	736-232	736-232	1.6	43	55	FG3760	136-134	FG3478	1436-115	.18-.22		
1959	336A	Scott	40E	12076	936-101	Wico	X11352	3685-113	2.00	40	60	FG3761	936-134	X11362	3685-115	.26-.30		
	332A	Scott	60		332-101	Phel	FG3437	332-113	1.0	55	75	FG3760	136-134	FG3044	332-115	.24-.28		
							FG3681	432-113	1.8	55	75	X11710	435-113					

McCULLOCH CORP. OUTBOARD MOTOR SPECIFICATIONS (Cont'd.)

Year	Eng. No.	Mc	HP	Stator Assy. No.		Mfg. Make	Coil No.		Oper. Amp.	Secondary Continuity Min. Max.	Generator Coil		Condenser No.		Capacity Microfarads
				Mfg.	Scott		Mfg.	Scott			Mfg.	Scott	Mfg.	Scott	
1960	A30B	Scott	3.5		130-101	Phelon	FG3689	138-134	2.5	40 - 60			FG3693	138-115	.15-.19
1960	A3KE	Scott	6.0	134-101	134-101	McCul	134-134	134-134	1.9	30 - 45			X12293	134-115	.18-.22
1960	A3EB	Scott	7.5	134-101	134-101	McCul	134-134	134-134	1.9	30 - 45			X12293	134-115	.18-.22
1960	C3EB	Scott	7.5	134-101	134-101	McCul	134-134	134-134	1.9	30 - 45			X12293	134-115	.18-.22
1960	A3FB	Scott	12		139-101	Phelon	FG4138	139-134	2.5	40 - 60			FG3693	138-115	.15-.19
1960	A3GB	Scott	25M		735-101	Wico	X11352	3685-113	2.0	40 - 60			X11362	3685-115	.26-.30
1960	B3GB	Scott	25ML		735-101	Wico	X11352	3685-113	2.0	40 - 60			X11362	3685-115	.26-.30
1960	C3GB	Scott	25E		735-101	McCul		4368-134	1.4	40 - 60			X11362	3685-115	.26-.30
1960	D3GB	Scott	25EL		735-101	McCul		3358-134 Top Bottom	1.4	40 - 60			X11362	3685-115	.26-.30
1960	A3HB	Scott	40M		1368-101	Wico	X11352	3685-113	2.0	40 - 60			X11362	3685-115	.26-.30
1960	B3HB	Scott	40ML		1368-101	Wico	X11352	3685-113	2.0	40 - 60			X11362	3685-115	.26-.30
1960	C3HB	Scott	40E		3368-200	McCul	4368-134	4368-134	1.4	45 - 60			X12264	3358-115	.26-.30
1960	D3HB	Scott	40EL		3368-200	McCul	4368-134	4368-134 Top	1.4	45 - 60			X12264	3358-115	.26-.30
1960	E3HB	Scott	40R		3368-200	McCul	4368-134	4368-134 Top	1.4	45 - 60			X12264	3358-115	.26-.30
1960	F3HB	Scott	40RL		3368-200	McCul	4368-134	4368-134 Bottom Bottom	1.4	45 - 60			X12264	3358-115	.26-.30
1960	C3JB	Scott	60E			McCul	C3JB-232	532-134	1.4	45 - 60			3328-115		.25-.27
1960	D3JB	Scott	60EL			McCul	C3JB-232	C3JB-232	1.4	45 - 60			3328-115		.25-.27
1960	C3LB	Scott	60E			McCul	C3JB-232	532-134	1.4	45 - 60			3328-115		.25-.27
1960	D3LB	Scott	60EL			McCul	C3JB-232	C3JB-232	1.4	45 - 60			3328-115		.25-.27

McCULLOCH CORP. OUTBOARD MOTOR SPECIFICATIONS (Cont'd)

Year	Eng. No.	HP	Coil Number			Oper. Amp.	Prim. Res. Min. Max.	Sec. Cont. Min. Max.	Condenser No.		Capacity Microfarads
			Make	Mfg.	Scott				Mfg.	Scott	
1961	61300310	3.6	Phelon	FG3689	138-134	2.5		45 - 60	FG3693	138-115	.15- .19
1961	61300610	6.0	Phelon	FG6001	A3EC-134	2.5		45 - 60	FG4477	A3EC-115	.15- .19
1961	61300710	7.5	Phelon	FG6001	A3EC-134	2.5		45 - 60	FG4477	A3EC-115	.15- .19
1961	61301210 61301220	14.1	Phelon	FG4128	139-134	2.5		40 - 55	FG3693	138-115	.15- .19
1961	61302530 61302540 61302550 61302560	27.7	McCul	C3HC-134	(top) C3HC-134	1.4	.55- .85	45 - 55	X12264	335B-115	.26- .30
		27.7	McCul	D3HC-134	(bottom) D3HC-134	1.4	.55- .85	45 - 55	X12264	335B-115	.26- .30
8 1961	61302510 61302520	27.7	Wico	X11352	3685-113	2.0		45 - 60	X11362	3685-115	.26- .30
1961	61304031 61304041 61304051 61304061	43.7	McCul	436B-134	(top) 436B-134	1.4	.55- .85	45 - 60	X12264	335B-115	.26- .30
		43.7	McCul	336B-134	(bottom) 336B-134	1.4	.55- .85	45 - 60	X12264	335B-115	.26- .30
1961	61304011 61304021	43.7	Wico	X11352	3685-115	2.0		40 - 60	X11362	3685-115	.26- .30
1961	61306031 61306041	60.0	McCul	C3JB-134	C3JB-134	1.4	.55- .85	45 - 55	332B-115	332B-115	.25- .27
1961	61307031 61307071 61307041 61307081	75.2	McCul	C3JB-134	C3JB-134	1.4	.55- .85	45 - 55	332B-115	332B-115	.25- .27

McCULLOCH CORP. OUTBOARD MOTOR SPECIFICATIONS (Cont'd)

Year	Eng. No.	HP	Coil Number			Oper. Amp.	Prim. Res. Min. Max.	Sec. Cont. Min. Max.	Condenser No.		Capacity Microfarads
			Make	Mfg.	Scott				Mfg.	Scott	
1962	62300310	3.6	Phelon	FG3689	138-134	2.5		45 - 60	FG3693	138-115	.15-.19
	62300410	3.6	Phelon	FG3689	138-134	2.5		45 - 60	FG3693	138-115	.15-.19
	62300610	6.0	Phelon	FG6001	A3EC-134	2.5		45 - 60	FG4477	A3EC-115	.15-.19
	62300710	7.5	Phelon	FG6001	A3EC-134	2.5		45 - 60	FG4477	A3EC-115	.15-.19
	62300810	7.5	Phelon	FG6001	A3EC-134	2.5		45 - 60	FG4477	A3EC-115	.15-.19
	62301410	14.1	Phelon	FG4128	139-134	2.5		40 - 55	FG3693	138-115	.15-.19
	62301420	14.1	Phelon	FG4128	139-134	2.5		40 - 55	FG3693	138-115	.15-.19
1962	62302610	27.7	Wico	X11352	3685-113	2.0		45 - 60	X11362	3685-115	.26-.30
	62302710	27.7	Wico	X11352	3685-113	2.0		45 - 60	X11362	3685-115	.26-.30
1962	62302730	27.7	McC		C3HC-134	1.4	.55-.85	45 - 60	X12264	335B-115	.26-.30
1962	62302810	27.7	Wico	X11352	3685-113	2.0		45 - 60	X11362	3685-115	.26-.30
	62302820	27.7	Wico	X11352	3685-113	2.0		45 - 60	X11362	3685-115	.26-.30
1962	62302830	27.7	McC		C3HC-134	1.4	.55-.85	45 - 60	X12264	335B-115	.26-.30
	62302840	27.7	McC		C3HC-134	1.4	.55-.85	45 - 60	X12264	335B-115	.26-.30
1962	62304410	43.7	Wico	X11352	3685-113	2.0		45 - 60	X11362	3685-115	.26-.30
	62304420	43.7	Wico	X11352	3685-113	2.0		45 - 60	X11362	3685-115	.26-.30
1962	62304430	43.7			71230A	.95	1.15 - 1.4	60 - 70	X12264	335B-115	.26-.30
	62304440	43.7			71230A	.95	1.15 - 1.4	60 - 70	X12264	335B-115	.26-.30
	62304450	43.7			71230A	.95	1.15 - 1.4	60 - 70	X12264	335B-115	.26-.30
	62304360	43.7			71230A	.95	1.15 - 1.4	60 - 70	X12264	335B-115	.26-.30
	62304350	43.7			71230A	.95	1.15 - 1.4	60 - 70	X12264	335B-115	.26-.30
1962	62307530	75.2			71198	.95	1.1 - 1.3	60 - 70	332B-115	332B-115	.25-.27
	62307540	75.2			71198	.95	1.1 - 1.3	60 - 70	332B-115	332B-115	.25-.27
	62307030	75.2			71198	.95	1.1 - 1.3	60 - 70	332B-115	332B-115	.25-.27
	62307040	75.2			71198	.95	1.1 - 1.3	60 - 70	332B-115	332B-115	.25-.27
	62307630	75.2			71198	.95	1.1 - 1.3	60 - 70	332B-115	332B-115	.25-.27

100

McCULLOCH CORP. OUTBOARD MOTOR SPECIFICATIONS (cont'd)

Model No.	H.P.	Make	COIL NUMBER		Oper. Amp.	Primary Resistance Min.-Max.	Secondary Continuity Min.-Max.	CONDENSER NO.		Capacity Microfarad Min.-Max.
			Mfg.	Scott				Mfg.	Scott	
63300311	3.5	Phelon	FG3689	1380134	2.5		45 - 60	FG3693	1380115	.15 - .19
63300411	3.5	Phelon	FG3689	1380134	2.5		45 - 60	FG3693	1380115	.15 - .19
63300711	7.5	Phelon	FG6001	76088	2.5		45 - 60	FG4477	76065	.15 - .19
63300712	7.5	Phelon	FG6001	76088	2.5		45 - 60	FG4477	76065	.15 - .19
63300750	7.5	Phelon	FG6001	76088	2.5		45 - 60	FG4477	76065	.15 - .19
63301411	14.1	Phelon	FG4128	1390134	2.5		40 - 55	FG3693	1380115	.15 - .19
63301412	14.1	Phelon	FG4128	1390134	2.5		40 - 55	FG3693	1380115	.15 - .19
63301491	14.1	Phelon	FG4128	1390134	2.5		40 - 55	FG3693	1380115	.15 - .19
63302811	28	Wico	X11352	36850113	2.0		45 - 60	X11362	36850115	.26 - .30
63302821										
63302831	28	McC		TOP 76089	1.4	.55 - .85	45 - 60	X11264	76067	.26 - .30
				BOTTOM 76092	1.4	.55 - .85	45 - 60	X11264	76067	.26 - .30
63302841	28									
63304511	45	Wico	X11352	36850113	2.0		45 - 60	X11362	36850115	.26 - .30
63304521	45	Wico	X11352	36850113	2.0		45 - 60	X11362	36850115	.26 - .30
63304531	45	Andover		71230A	1.1	1.0 - 1.4	60 - 70	X11264	76067	.26 - .30
63307531	75	Andover		71198	1.0	1.0 - 1.4	60 - 70		76066	.25 - .27
63307541	75	Andover		71198	1.0	1.0 - 1.4	60 - 70		76066	.25 - .27
63307533	75	Andover		75455	1.0	1.0 - 1.4	60 - 70		76066	.25 - .27
63307543										

101

1964 McCULLOCH CORP. OUTBOARD MOTOR SPECIFICATIONS (cont'd)

102

Model No.	H.P.	Make	COIL NUMBER		Oper. Amp.	Primary Resistance Min.-Max.	Secondary Continuity Min.-Max.	CONDENSER NO.		Capacity Microfarad Min.-Max.
			Mfg.	Scott				Mfg.	Scott	
64300310	3.5	Phelon	FG3689	1380134	2.5		45 - 60	FG3693	1380115	.15 - .19
64300410	3.5	Phelon	FG3689	1380134	2.5		45 - 60	FG3693	1380115	.15 - .19
64300710	7.5	Phelon	FG6001	76088	2.5		45 - 60	FG4477	76065	.15 - .19
64300750	7.5	Phelon	FG6001	76088	2.5		45 - 60	FG4477	76065	.15 - .19
64301410	14	Phelon	FG4128	1390134	2.5		40 - 55	FG3693	1380115	.15 - .19
14000200	14	Phelon	FG4128	1390134	2.5		40 - 55	FG3693	1380115	.15 - .19
64302810	28	Wico	X11135	36850113	2.0		45 - 60	X11362	36850115	.26 - .30
64302830	28	McCul		TOP CYL						
				76089	1.4		45 - 60	X11264	76067	.26 - .30
				BOTTOM						
				76092	1.4		45 - 60	X11264	76067	.26 - .30
64304510	45	Wico	X11352	36850113	2.0		45 - 60	X11362	36850115	.26 - .30
64304520	45	Wico	X11352	36850113	2.0		45 - 60	X11362	36850115	.26 - .30
64304530	45	Andover		71230A	1.1	1.0 - 1.4	60 - 70	X11264	76067	.26 - .30
64304540	45	Andover		71230A	1.1	1.0 - 1.4	60 - 70	X11264	76067	.26 - .30
	45			7387-5	1.0	1.1 - 1.4	55 - 65			
64307530	75	Andover		75455	1.0	1.0 - 1.4	60 - 70	X11264	76066	.25 - .27
64307543	75	Andover		75455	1.0	1.0 - 1.4	60 - 70	X11264	76066	.25 - .27
	75			79670	.85	1.02 - 1.42	55 - 65		76066A	.18 - .22

1965-66 McCULLOCH CORP. OUTBOARD MOTOR SPECIFICATIONS (cont'd)

Model No.	H.P.	Make	COIL NUMBER		Oper. Amp.	Primary Resistance Min. Max.	Secondary Continuity Min. Max.	CONDENSER NO.		Capacity Microfarad Min. Max.
			Mfg.	McCulloch				Mfg.	McCulloch	
65300710	7.5	Phelon	FG6001	76088	2.5		45 - 60	FG4477	76065	.15- .19
65300750	7.5	Phelon	FG6001	76088	2.5		45 - 60	FG4477	76065	.15- .19
65301410	14	Phelon	FG4128	1390134	2.5		40 - 55	FG3693	1380115	.15- .19
14000200	14	Phelon	FG4128	1390134	2.5		40 - 55	FG3693	1380115	.15- .19
65302810	28	Wico	X11135	36850113	2.0		45 - 60	X11362	36850115	.26- .30
65302830	28	McCul		TOP CYL 76089	1.4		45 - 60	X11264	76067	.26- .30
				BOTTOM 76092	1.4		45 - 60	X11264	76067	.26- .30
65304510	45	Wico	X11352	36850113	2.0		45 - 60	X11362	36850115	.26- .30
65304520	45	Wico	X11352	36850113	2.0		45 - 60	X11362	36850115	.26- .30
65304530	45	Andover		71230A	1.1	1.0- 1.4	60 - 70	X11264	76067	.26- .30
65304540	45	Andover		71230A	1.1	1.0- 1.4	60 - 70	X11264	76067	.26- .30
	45			73875	1.0	1.1- 1.4	55 - 65			
65307530	75	Andover		75455	1.0	1.0- 1.4	60 - 70	X11264	76066	.25- .27
65307543	75	Andover		75455	1.0	1.0- 1.4	60 - 70	X11264	76066	.25- .27
	75			79670	.85	1.02-1.42	55 - 65		76066A	.18- .22
140-OX	14	Phelon	FG4128	1390134	2.5		40 - 55	FG3693	1380115	.15- .19
450-OX	45	Wico	X11352	36850113	2.0		45 - 60	X11262	36850115	.26- .30

McCULLOCH CORP. SUPPLEMENT SPECIFICATIONS FOR
CHAIN SAWS

Coil No. McCulloch	Operating Amperage	Primary Continuity Min. Max.	Secondary Continuity Min. Max.	Condenser No. Mfg.	McCulloch	Capacity Microfarads Min. Max.
62927 (E65)	1.5	.7 - .8	55 - 65			
79566 (K4)	1.1	.6 - .8	45 - 55			
79566 (K4)	1.1	.6 - .8	45 - 55			
76090	1.1	.6 - .9	45 - 55			
76959 (K4)	1.1	.6 - .9	45 - 55			
76091	1.1	.6 - .9	45 - 55			
PN71198A	.9	1.15-1.45	55 - 65			
55949A (C4)	1.5	.48- .55	45 - 55			

TARGET AIRCRAFT ENGINE

10471 (C65)	1.0	.4 - .5	42 - 52	X10455B	1008395	.18- .23
-------------	-----	---------	---------	---------	---------	----------

NOTE: 2 Coils mounted on one U shaped Lamination. Coils are connected in series.
When testing, connect the 2 negative leads together. There is only one Positive
Lead, two (2) High Tension Leads. Test each Coil separately by connecting
High Tension Lead from Analyzer to each Coil.

McCULLOCH
COIL SPECIFICATIONS

Coil No.	Operating Amperage	Primary Resistance Scale #2 Min. Max.	Secondary Continuity Min. Max.
19033C	2.4	.21 - .250	30 - 50
24033E	2.4	.21 - .250	30 - 50
51494	2.4	.21 - .250	30 - 50
51495	2.4	.21 - .250	30 - 50
55013	2.4	.21 - .250	37 - 48

McCULLOCH
CONDENSER SPECIFICATIONS

Condenser	Capacity Microfarads
All Models18- .22

ONAN ENGINE/GENERATOR DIVISION OF STUDEBAKER CORP.
COIL AND CONDENSER SPECIFICATIONS

Model No.	Stator Assembly	Coil No.	Operating Amperage	Primary Resistance Min. Max.	Secondary Continuity Min. Max.	Condenser No.	Condenser Microfarads Min. Max.
TC, TB & AH, AJ, AK CK (Prior to Spec. M)	160B305	160B155	2.7	.425-.475	48 - 60	312A1	.18- .22
		160B86	.75	.07 - .11	55 - 65	312A19	.3 - .7
BH		160B99	.75	.07 - .11	55 - 65	312A19	.3 - .7
CK (Spec. M)		166B268	.75	.1 - .14	33 - 43	312A69	.28- .32
CK (Spec. M)		166B91	.75		32 - 44	312A19	.3 - .7
CCK	162A237	166P259	.7	.2 - .25	54 - 65	312A100	.3 - .7
	162A196	160C483	1.2	.07 - .1	54 - 65	312A69	.28- .32

Model No.	Coil No.	Operating Amperage	Primary Resistance Min. Max.	Secondary Continuity Min. Max.	Condenser No.	Condenser Microfarads Min. Max.
CCK	160C792 Replaces 160C483 Prior Spec. "J"	.75	.7 - .8	50 - 60		
	166C346 Begin Spec. "J"	.9	.87-1.0	60 - 70		
	160K722 Stator Assy. Magneto (Coil)		.47- .53			
	160K750					
MCKK	160B750	1.2	.45- .51	50 - 60		
	166B382	.9	.85- .95	60 - 70	31283	1.44-2.16
(See Page 21 Fig. 26 for Test Procedure)						
MJA	166B278	.5	3.0 -3.5	50 - 60		
JA	166B278	.5	3.0 -3.5	50 - 60		
MJB	160C792 Replaces 160C483 Prior Spec. "J"	.75	.7 - .8	50 - 60		
	166B278 Begin Spec. "J"	.5	3.0 -3.5	50 - 60		
JB	166B278	.5	3.0 -3.5	50 - 60		
MJC	166B278	.5	3.0 -3.5	50 - 60		
JC					312A116	.24- .34

NOTE: All Coils with Double Secondary Lead see Page 23 Fig. 26 for Test Procedure. We are unable to test Condenser #31283.

OLIVER OUTBOARD MOTORS COIL AND
CONDENSER SPECIFICATIONS

Coil No.	Operating Amperage	Secondary Continuity Min. Max.	Condenser No.	Capacity Reading in Microfarads Min. Max.
10-94097	1.8	25 - 45	10-82104	.13 - .17
10-111287	1.8	38 - 58	10-88603	.23 - .27

O & R ENGINES COIL AND CONDENSER SPECIFICATIONS

Coil No.	Mfg.	Mfg. No.	Operating Amperage	Secondary Continuity Min. Max.	Condenser No.	Capacity Reading in Microfarads Min. Max.
A-149-3	Phelon	6599	1.6	48 - 58	FG6325	.25 - .27

R. E. PHELON CONDENSER SPECIFICATIONS

Condenser No.	Capacity Reading in Microfarads Min. Max.	Condenser No.	Capacity Reading in Microfarads Min. Max.
FG-159	.15- .19	FG-4016	.18- .22
FG-216 Series	.15- .19	FG-4082	.15- .19
FG-410 Series	.12- .16	FG-4312	.24- .28
FG-458 Series	.12- .16	FG-4449	.15- .19
FG-471 Series	.12- .16	FG-4477	.15- .19
FG-549	.12- .16	FG-5420A	.27- .33
FG-607	.15- .19	FG-5420B	.27- .33
FG-1019	.12- .16	FG-6048	.15- .19
FG-1057	.16- .20	FG-6168	.15- .19
FG-1205	.34- .38	FG-6170	.15- .19
FG-1316	.12- .16	FG-6225	.11- .15
FG-1338	.15- .19	FG-6325	.25- .27
FG-1355	.12- .16	FG-6453	.15- .19
FG-1770	.14- .18	FG-6548	.24- .28
FG-1807	.22- .27	FG-6548B	.24- .27
FG-1928	.22- .27	FG-6867	.12- .16
FG-2111	.12- .16	FG-7047	.19- .21
FG-2138	.12- .16	FG-7130	.16- .18
FG-2176	.15- .19	FG-7146	.19- .21
FG-2448	.12- .16	FG-7157	.16- .18
FG-2642	.12- .16	FG-7184	.25- .27
FG-2727	.18- .22	FG-7224	.16- .18
FG-2733	.15- .19	FG-7239	.19- .21
FG-2780	.12- .16	FG-7251	.12- .14
FG-2993	.18- .22	FG-7270	.16- .18
FG-3044	.24- .28	FG-7437	.13- .16
FG-3478	.18- .22	FG-7460	.16- .18
FG-3505	.16- .18	FG-7468	.12- .14
FG-3693	.15- .19	FG-7499	.16- .18
FG-3723	.16- .18	FG-7533	.13- .16

R. E. PHELON MAGNETO COIL SPECIFICATIONS

Coil No.	Operating Amperage	Secondary Continuity Min. Max.	Coil No.	Operating Amperage	Secondary Continuity Min. Max.
FG-114	2.5	40 - 60	FG-3437	1.0	55 - 75
(taped)			FG-3502	2.8	45 - 60
FG-307 Series	2.5	40 - 60	FG-3595	2.5	55 - 65
(taped)			FG-3681	1.8	55 - 75
FG-420 Series	2.8	40 - 60	FG-3689	2.5	40 - 60
FG-463 Series	2.8	40 - 60	FG-3755	2.5	40 - 60
(taped) B			FG-3755X	2.5	45 - 60
FG-470 Series	2.8	40 - 60	FG-3773	2.8	45 - 60
(taped) B			FG-3872	2.8	45 - 60
*FG-492 Series B	2.5	40 - 60	FG-4055	2.8	50 - 70
FG-608	2.5	45 - 65	FG-4081	2.8	40 - 60
FG-678	2.8	40 - 60	FG-4128	2.5	40 - 55
FG-1054	2.5	45 - 65	FG-4448	2.8	45 - 60
FG-1070	2.5	40 - 60	FG-5265	3.0	47 - 67
FG-1309	2.8	40 - 60	FG-5380	2.5	60 - 70
FG-1573 Series C	2.8	40 - 60	FG-5395	2.5	60 - 70
**FG-1618	2.8	40 - 60	FG-6001	2.5	40 - 60
FG-1641	2.2	50 - 70	FG-6235	2.8	55 - 70
FG-1835	2.5	45 - 65	FG-6240	2.7	50 - 65
FG-2145	2.8	40 - 60	FG-6388	2.8	45 - 60
FG-2180	2.8	40 - 60	FG-6446	2.6	45 - 61
FG-2331	2.8	40 - 60	FG-6547	1.0	60 - 75
FG-2435	2.8	50 - 60	FG-6599	3.0	57 - 67
FG-2446	2.8	40 - 60	FG-7049	2.8	61 - 71
FG-2454	2.5	40 - 60	FG-7151	2.8	61 - 71
FG-2503	2.8	50 - 60	FG-7168	2.0	35 - 50
FG-2546	2.5	40 - 60	FG-7202	1.8	50 - 60
FG-2641	2.8	40 - 60	FG-7256	2.8	61 - 71
FG-2723	2.8	40 - 60	FG-7271	2.6	57 - 67
FG-2732	2.8	40 - 60	FG-7423	2.1	52 - 62
FG-2914	2.8	40 - 60	FG-7427	2.1	52 - 62
FG-2976	2.8	50 - 70	FG-7447	2.6	57 - 67
FG-3082	2.8	50 - 70	FG-7459	2.6	57 - 67
FG-3289	2.8	50 - 60	FG-7469	2.25	60 - 70
FG-3294	2.8	40 - 60	FG-7502	2.7	54 - 64
FG-3375	2.8	35 - 55			

*Coils above are molded unless listed "taped".

*FG-492 Coil - Ground out one secondary terminal while testing other.

**FG-1618 Coil - Connect the core ends (common ground) during tests.

PIONEER CHAIN SAW COIL SPECIFICATIONS

Coil No.	Model No.	Mfg.	Operating Amperage	Primary Resistance Min. Max.	Secondary Continuity Min. Max.
X11180	600	Wico	1.8		35 - 55
470685	400	OMC	1.4	.5 - .7	40 - 55
471365	11-10	OMC	1.3	.6 - .7	50 - 60
580454	700	OMC	1.4	.4 - .6	30 - 40

PIONEER CHAIN SAW CONDENSER SPECIFICATIONS

Condenser No.	Capacity Reading In Microfarads Min. Max.
X11181	.16 - .20
426528	.18 - .22
471354	.16 - .20

PIONEER GEN-E-MOTOR COIL SPECIFICATIONS

Coil No.	Operating Amperage	Secondary Continuity Min. Max.
A60-084	2.8	40 - 60
C62-180	2.8	35 - 55
60-1030	2.8	40 - 60
60-1445	2.3	40 - 55

PIONEER GEN-E-MOTOR CONDENSER SPECIFICATIONS

Condenser No.	Capacity Reading in Microfarads Min. Max.
60-088	.18 - .22
60-1064	.18 - .22

VERTEX MAGNETO MANUFACTURED BY RONCO CORPORATION COIL SPECIFICATIONS

Coil No.	Operating Amperage	Primary Resistance Min. Max.	Secondary Continuity Min. Max.
1111	1.25	.35 - .45	45 - 50

Full power amperage approximately 2.6

VERTEX CONDENSER SPECIFICATIONS

Condenser No.	Capacity Reading In Microfarads Min. Max.
1210	.24

SEARS (FORMERLY ELGIN OUTBOARD MOTORS)

Motor Model No.	H. P.	Year	Wico Coil No.	Operating Amperage	Coil Continuity Min. Max.	Wico Cond. No.	Cond. Cap. Mfd.
571.58211	2	1954-56	X7500	2.10	30 - 50	X5463	.16- .20
571.58221	2	1957	X7500	2.10	30 - 50	X5463	.16- .20
571.58231	2	1958	X7500	2.10	30 - 50	X9182	.26- .30
571.58232	2	1958	X11406	2.10	43 - 54	X11397	.16- .20
571.58571	5	1954-56	X7500	2.10	30 - 50	X9182	.26- .30
571.59501	5-1/2	1956	X7500	2.10	30 - 50	X9327	.26- .30
571.59521	5-1/2	1957	X7500	2.10	30 - 50	X9327	.26- .30
571.59531	5-1/2	1958	X7500	2.10	30 - 50	X9327	.26- .30
571.59532	5-1/2	1958	X11406	2.10	40 - 60	X11397	.16- .20
571.58711	7-1/2	1955	X7500	2.10	30 - 50	X5463	.16- .20
571.59701	7-1/2	1956	X7500	2.10	30 - 50	X9327	.26- .30
571.58781	7-1/2	1957	X7500	2.10	30 - 50	X5463	.16- .20
571.59721	7-1/2	1957	X7500	2.10	30 - 50	X9327	.26- .30
571.59731	7-1/2	1957	X7500	2.10	30 - 50	X9327	.26- .30
571.58782	7-1/2	1958	X11406	2.10	40 - 60	X11397	.16- .20
571.59732	7-1/2	1958	X11406	2.10	40 - 60	X11397	.16- .20
571.58901	12	1955	X7500	2.10	30 - 50	X9327	.26- .30
571.58911	12	1955	X7500	2.10	30 - 50	X9327	.26- .30
571.58902	12	1956	X7500	2.10	30 - 50	X9327	.26- .30
571.58912	12	1956	X7500	2.10	30 - 50	X9327	.26- .30
571.58921	12	1956-57	X7500	2.10	30 - 50	X9327	.26- .30
571.58941	12	1957	X7500	2.10	30 - 50	X9327	.26- .30
571.58942	12	1957	X7500	2.10	30 - 50	X9327	.26- .30
571.58951	12	1957	X7500	2.10	30 - 50	X9327	.26- .30
571.58952	12	1957	X7500	2.10	30 - 50	X9327	.26- .30
571.58931	12	1958	X11406	2.10	40 - 60	X11397	.16- .20
571.58961	12	1958	X7500	2.10	30 - 50	X9327	.26- .30
571.58962	12	1958	X7500	2.10	30 - 50	X9327	.26- .30
571.58971	12	1958	X7500	2.10	30 - 50	X9327	.26- .30
571.58972	12	1958	X7500	2.10	30 - 50	X9327	.26- .30

SEARS (FORMERLY ELGIN OUTBOARD MOTORS Cont'd)

Motor Model No.	H.P.	Year	Fairbanks-Morse Coil No.	Operating Amperage	Coil Continuity Min. Max.	Fairbanks-Morse Cond. No.	Cond. Cap. Mfd.
571.59402	25	1956	LX2477	1.50	40 - 60	S2433	.28 - .33
571.59403	25	1956	LX2477	1.50	40 - 60	S2433	.28 - .33
571.59412	25	1956	LX2477	1.50	40 - 60	S2433	.28 - .33
571.59413	25	1956	LX2477	1.50	40 - 60	S2433	.28 - .33
571.59601	25	1956	LX2477	1.50	40 - 60	S2433	.28 - .33
571.59611	25	1956	LX2477	1.50	40 - 60	S2433	.28 - .33
571.59421	30	1957	LX2477	1.50	40 - 60	S2433	.28 - .33
571.59431	30	1957	LX2477	1.50	40 - 60	S2433	.28 - .33
571.59621	30	1957	LX2477	1.50	40 - 60	S2433	.28 - .33
571.59631	30	1957	LX2477	1.50	40 - 60	S2433	.28 - .33
571.59601	30	1957	LX2477	1.50	50 - 60	S2433	.28 - .33
571.59811	30	1957	LX2477	1.50	40 - 60	S2433	.28 - .33
571.59441	35	1958	LX2477	1.50	40 - 60	S2433	.28 - .33
571.59451	35	1958	LX2477	1.50	40 - 60	S2433	.28 - .33

SEARS (FORMERLY ELGIN OUTBOARD MOTORS Cont'd)

Model Number	H.P.	Year	Ignition Mfg.	Coil Number	Operating Amperage	Continuity Min. Max.	Condenser Number	Capacity Microfarads
571.59821	35	1958	Wico	X11563	0.75	40 - 60	X11337	.26 - .30
571.59831	35	1958	Wico	X11563	0.75	40 - 60	X11337	.26 - .30
571.59901	35	1958	Wico	X11563	0.75	40 - 60	X11337	.26 - .30
571.59911	35	1958	Wico	X11563	0.75	40 - 60	X11337	.26 - .30
574.60250	25	1959	Phelon	FG3755	2.5	40 - 60	FG3478	.18 - .22
574.60270	25	1959	Phelon	FG3755	2.5	40 - 60	FG3478	.18 - .22
574.60400	40	1959	Phelon	FG3755	2.5	40 - 60	FG3478	.18 - .22
574.60420	40	1959	Phelon	FG3755	2.5	40 - 60	FG3478	.18 - .22
574.60600	60	1959	Phelon	FG3681	1.8	55 - 75	FG3044	.24 - .28
574.60610	60	1959	Phelon	FG3681	1.8	55 - 75	FG3044	.24 - .28

ELGIN OUTBOARD MOTORS (Cont'd)

Model No.	HP	Year	Coil No.	Coil Manf.	Manf's No.	Oper. Amp.	Prim. Res. Min.-Max.	Sec. Cont. Min.-Max.	Cond. No.	Cond. Manf.	Manfs. No.	Capacity Microfarads
A6BB	3.6	1960	138-134	Phelon	FG3689	2.5		40 - 60	138-115	Phelon	FG3693	.15-.19
A6KB	6.0	1960	134-134	McCul	Same	1.9		30 - 45	134-115	Wico	X12293	.18-.22
C6EB	7.5	1960	134-134	McCul	Same	1.9		30 - 45	134-115	Wico	X12293	.18-.22
A6FB	12.	1960	139-134	Phelon	FG4128	2.5		40 - 60	138-115	Phelon	FG3693	.15-.19
A6GB	25 M	1960	3685-113	Wico	X11352	2.0		40 - 60	3685-115	Wico	X11362	.26-.30
B6GB	25M	1960	3685-113	Wico	X11352	2.0		40 - 60	3685-115	Wico	X11362	.26-.30
C6GB	25E	1960	336B-134	McCul	Same	1.4	.55-.85	40 - 60	335B-115	Wico	X12264	.26-.30
D6GB	25E	1960	436B-134	McCul	Same	1.4	.55-.85	40 - 60	335B-115	Wico	X12264	.26-.30
A6HB	40M	1960	3685-113	Wico	X11352	2.0		40 - 60	3685-115	Wico	XX11362	.26-.30
B6HB	40M	1960	3685-113	Wico	X11352	2.0		40 - 60	3685-115	Wico	X11362	.26-.30
C6HB	40E	1960	336B-134	McCul	Same	1.4	.55-.85	40 - 60	335B-115	Wico	X12264	.26-.30
D6HB	40E	1960	436B-134	McCul	Same	1.4	.55-.85	40 - 60	335B-115	Wico	X12264	.26-.30
C6JB	60	1960	532-134	McCul	Same	1.4		45 - 60	332B-115	McCul	332B-115	.25-.27
D6JB	60	1960	532-134	McCul	Same	1.4		45 - 60	332B-115	McCul	332B-115	.25-.27
61600310	3.6	1961	138-134	Phelon	FG3689	2.5		40 - 60	138-115	Phelon	FG3693	.15-.19
61600610	6.0	1961	A3EC-134	McCul	Same	2.5		45 - 60	A3EC-115	Phelon	FG4477	.15-.19
61600710	7.5	1961	A3EC-134	McCul	Same	2.5		45 - 60	A3EC-115	Phelon	FG4477	.15-.19
61601210	14.1	1961	139-134	Phelon	FG4128	2.5		40 - 60	138-115	Phelon	FG3693	.15-.19
61602510	27.7M	1961	3685-113	Wico	X11352	2.0		40 - 60	3685-115	Wico	X11362	.26-.30
61602510	27.7	1961	3685-113	Wico	X11352	2.0		40 - 60	3685-115	Wico	X11362	.26-.30
61602530	27.7E	1961	C3HC-134	McCul	Same	1.4	.55-.85	45 - 55	335B-115	Wico	X12264	.26-.30
61602530	27.7E	1961	D3HC-134	McCul	Same	1.4	.55-.85	45 - 55	335B-115	Wico	X12264	.26-.30
61604030	43.7E	1961	C3HC-134	McCul	Same	1.4	.55-.85	45 - 55	335B-115	Wico	X12264	.26-.30
61604040	43.7E	1961	D3HC-134	McCul	Same	1.4	.55-.85	45 - 55	335B-115	Wico	X12264	.26-.30
61607030	75.2E	1961	C3JB-134	McCul	Same	1.4	.55-.85	45 - 55	332B-115	McCul	Same	.25-.27
61607040	75.2E	1961	C3JB-134	McCul	Same	1.4	.55-.85	45 - 55	332B-115	McCul	Same	.25-.27

* Wico

ELGIN OUTBOARD MOTORS

** Fairbanks-Morse

Motor Model No.	H.P.	Year	Coil No.	Operating Amp.	Continuity Min. Max.	Cond. No.	Capacity Microfarads
571.58241	2	1959	* X11406	2.1	40 - 60	* X11397	.16-.20
571.58791	7-1/2	1959	* X11406	2.1	40 - 60	* X11397	.16-.20
571.58801	12	1959	* X11406	2.1	40 - 60	* X11397	.16-.20
571.58811	12	1959	* X11406	2.1	40 - 60	* X11397	.16-.20
571.58802	12	1959	* X11406	2.1	40 - 60	* X11397	.16-.20
571.58812	12	1959	* X11406	2.1	40 - 60	* X11397	.16-.20
571.58963	12	1959	* X11406	2.1	40 - 60	* X11397	.16-.20
571.58973	12	1959	* X11406	2.1	40 - 60	* X11397	.16-.20
571.58981	12	1959	* X11406	2.1	40 - 60	* X11397	.16-.20
571.58991	12	1959	* X11406	2.1	40 - 60	* X11397	.16-.20
571.59541	5-1/2	1959	* X11406	2.1	40 - 60	* X11397	.16-.20
571.59741	7-1/2	1959	* X11406	2.1	40 - 60	* X11397	.16-.20
571.58321	2	1960	* X11406	2.1	40 - 60	* X11397	.16-.20
571.59221	2	1960	* X11406	2.1	40 - 60	* X11397	.16-.20
571.59271	7-1/2	1960	* X11406	2.1	40 - 60	* X11397	.16-.20
571.59281	7-1/2	1960	* X11406	2.1	40 - 60	* X11397	.16-.20
571.59301	8	1960	* X11406	2.1	40 - 60	* X11397	.16-.20
571.59551	12	1960	* X11406	2.1	40 - 60	* X11397	.16-.20
571.59641	18	1960	* X12302	2.2	40 - 55	* X12303	.16-.20
571.59651	18	1960	* X12302	2.2	40 - 55	* X12303	.16-.20
571.59791	7-1/2	1960	* X11406	2.1	40 - 60	* X11397	.16-.20
571.59881	12	1960	* X11406	2.1	40 - 60	* X11397	.16-.20
571.58322	2	1961	* X12660	1.8	40 - 55	* X12174	.16-.20
571.58331	2	1962	* X12660	1.8	40 - 55	* X12174	.16-.20
571.58341	7-1/2	1962	* X11406	2.1	40 - 60	* X11397	.16-.20
571.58351	3-1/2	1962	* X12660	1.8	40 - 55	* X12174	.16-.20

Year-1962

SEARS (FORMERLY ELGIN OUTBOARD MOTORS (Cont'd))

Elgin No.	Model No.	H. P.	Mfg.	Coil No.	Elgin No.	Oper. Amps	Primary Resistance		Secondary Resistance		Condenser		Elgin No.	Primary Resistance	
							Min.	Max.	Min.	Max.	Mfg.	No.		Min.	Max.
574-60020	62600310	3.6	Phelon	FG3689	1380134	2.5			40 - 60	Phelon	FG3693	1380115	.15 - .19		
574-60051	62600610	6.0	Phelon	FG6001	76088	2.5			45 - 60	Phelon	FG4477	76065	.15 - .19		
574-60081	62600710														
574-60131	62601410	14.1	Phelon	FG4128	1390134	2.5			40 - 55	Phelon	FG3693	1380115	.15 - .19		
574-60331	62602810	27.7	Wico	X11135	36850113	2.0			45 - 60	Wico	X11362	36850115	.26 - .30		
574-60351	62602820	27.7	Wico	X11135	36850113	2.0			45 - 60						
574-60332	62602830	27.7	Wico	X11135	36850113	2.0			45 - 60	Wico	X11362	36850115	.26 - .30		
574-60352	62602830	27.7	Wico	X11135	36850113	2.0			45 - 60	Wico	X11362	36850115	.26 - .30		
574-60333	62602840	27.7	Wico	X11135	36850113	2.0			45 - 60	Wico	X11362	36850115	.26 - .30		
574-60353	62602840	27.7	Wico	X11135	36850113	2.0			45 - 60	Wico	X11362	36850115	.26 - .30		
574-60522	62604432	40.0	McCul	Top	76089	1.4	.55 - .85		45 - 60	Wico	X11264	76067	.26 - .30		
574-60532	62604442	40.0		Bottom	76092	1.4	.55 - .85		45 - 60	Wico	X11264	76067	.26 - .30		
574-60520	62604430	43.7													
574-60530	62604440														
574-61521	62604431	43.7	Wico	X11135	36850113	2.0			45 - 60	Wico	X11362	36850115	.26 - .30		
574-61531	62604441														
574-60720	62607523	75.0	McCul		76091	1.10	.6 - .9		45 - 55			76066A	.25 - .27		
574-60730	62607540														
	Year - 1963														
574-60021	63600311	3.5	Phelon	FG3689	1380134	2.5			40 - 60	Phelon	FG3693	13800115	.15 - .19		
574-60090	63600711	7.5	Phelon	FG6001	7688	2.5			45 - 60	Phelon	FG4477	76065	.15 - .19		
574-60091	63600712	7.5													
574-60140	63601410	14.0	Phelon	FG4128	1390134	2.5			40 - 55	Phelon	FG3693	13800115	.15 - .19		
574-60340	63602810	28.0	Wico	X11352	36850113	2.0			45 - 60	Wico	X11362	36850115	.26 - .30		
574-60360	63602830	28.0													
574-60540	63604530	45.0	McCul	Top	76089	1.4	.55 - .85		45 - 60	Wico	X11264	76067	.26 - .30		
574-60550	63604540	45.0	McCul	Bottom	76092	1.4	.55 - .85		45 - 60	Wico	X11264	76067	.26 - .30		
574-60541	63604531	45.0													
574-60551	63604541	45.0													
574-60740	63607530	75.0	McCul		76091	1.10	.6 - .9		45 - 55	Wico	X11264	76067	.26 - .30		
574-60750	63607540	75.0													
574-60741	63607531	75.0	McCul		76091	1.10	.6 - .9		45 - 55			76066A	.25 - .27		
574-60751	63607541	75.0										76066A	.25 - .27		

Year-1964

SEARS MOTORS

Sears No.	Model No.	H. P.	Mfg.	Coil No.	Sears No.	Oper. Amps	Primary Resistance Min. Max.	Secondary Resistance Min. Max.	Condenser		Sears No.	Capacity Microfarads Min. Max.
									Mfg.	No.		
574-60030	64600310	3.5	Phelon	FG3689	1380134	2.5		40 - 60	Phelon	FG3693	1380115	.15-.19
574-60100	64600710	7.5	Phelon	FG6001	76088	2.5		45 - 60	Phelon	FG4477	76065	.15-.19
574-60150	64601410	14.0	Phelon	FG4128	1390134	2.5		40 - 55	Phelon	FG3693	1380115	.15-.19
574-60370	64602810	28.0	Wico	X11352	36850113	2.0		45 - 60	Wico	X11362	36850115	.26-.30
574-60380	64602830	28.0	McCul		76089-Top	1.4	.55-.85	45 - 60	Wico	X11264	76067	.26-.30
					76092-Bot	1.4	.55-.85	45 - 60	Wico	X11264	76067	.26-.30
574-60560	64604530	45.0	McCul		76089-Top	1.4	.55-.85	45 - 60	Wico	X11264	76067	.26-.30
					76092-Bot	1.4	.55-.85	45 - 60	Wico	X11264	76067	.26-.30
574-60570	64604540	45.0										
574-60760	64607530	75.0	McCul		79566	1.10	.6-.9	45 - 55			76066A	.26-.27
574-60770	64607540	75.0	McCul		79566						76066A	.25-.27
574-60761	6460753T	75.0	McCul		76090	1.10	.6-.9	45 - 55			76066A	.25-.27
574-60771	64607541	75.0	McCul		76090						76066A	.25-.27
574-60762	64607532	75.0	McCul		76091	1.10	.6-.9	45 - 55			76066A	.25-.27
574-60772	64607542	75.0	McCul		76091						76066A	.25-.27
Year - 1965-66												
574-60110	65600610	6.0	Phelon	FG6001	76088	2.5		45 - 60	Phelon	FG4477	76065	.15-.19
574-60120	65600710	7.5	Phelon	FG6001	76088	2.5		45 - 60	Phelon	FG4477	76065	.15-.19
574-60580	65604510	45.0	Andov		73875	1.0	1.1-1.4	55 - 65	Wico	X11264	76067	.26-.30
574-60780	65607530	75.0	McCul		79566	1.10	.6-.9	45 - 55			76066A	.25-.27
574-60790	65607540	75.0	McCul		79566	1.10	.6-.9	45 - 55			76066A	.25-.27
5929		2.0	Wico	X12660		1.8		40 - 55	Wico	X12174		.16-.20
5930		10.0	Wico	X11406		2.1		40 - 60	Wico	X11397		.16-.20
57159271		12.0	Wico	X14877		1.4	.4-.6	50 - 60	Wico	X11397		.16-.20
57159414		35.0	Fair	TX2477		1.5	.62-.68	45 - 55	Fair	S2433		.28-.32
57159415		35.0	Fair	TX2477		1.5	.62-.68	45 - 55	Fair	S2433		.28-.32

SEARS AIR-COOLED OUTBOARD ENGINES

Sears Model No.	H. P.	Sears Coil No.	Mfg.	Coil No.	Operating Amperage	Secondary Continuity Min. Max.	Condenser		Sears No.	Capacity Reading in Microfarads Min. Max.
							Mfg.	No.		
582-595900	3.5	135-13-990	Phelon	FG5770	2.8	40 - 60	Phelon	FG5589A	135-29-990	.15 - .19
582-60900	3.5	135-13-990	Phelon	FG5770	2.8	40 - 60				
582-60910	3.5	135-13-990	Phelon	FG5770	2.8	40 - 60				
582-60920	3.5	135-13-990	Phelon	FG5770	2.8	40 - 60				
582-60940	3.5	135-13-990	Phelon	FG5770	2.8	40 - 60				
582-60941	3.5	135-13-990	Phelon	FG5770	2.8	40 - 60				

SPIEGEL'S - "BROOKLURE"

Model No.	H. P.	Year	Magneto No.	Coil No.	Operating Amperage	Continuity Min. Max.	Condenser No.	Capacity Microfarads
50-T-3338	12	1957	580207	580416	1.7	30 - 40	580321	.18-.22
50-Z-3325	12	1958	580254	580416	1.7	30 - 40	580321	.18-.22
230-55-22DS	22	1955	580180	580416	1.7	30 - 40	580321	.18-.22
230-55-22DE	22	1955	580180	580416	1.7	30 - 40	580321	.18-.22
50-T-3345	25	1956	580209	580416	1.7	30 - 40	580321	.18-.22
50-T-3346	25	1956	580209	580416	1.7	30 - 40	580321	.18-.22
50-T-3339	25	1957	580209	580416	1.7	30 - 40	580321	.18-.22
50-T-3340	25	1957	580209	580416	1.7	30 - 40	580321	.18-.22
50-Z-3326	25	1958	580274	580416	1.7	30 - 40	580321	.18-.22
50-Z-3327	25	1958	580274	580416	1.7	30 - 40	580321	.18-.22

SPIEGEL'S - "BROOKLURE"

Model No.	H. P.	Year	Magneto No.	Coil No.	Operating Amperage	Continuity Min. Max.	Condenser No.	Capacity Microfarads
230-50-5	5	1950	590181	375189	1.9	30 - 45	300153	.15-.205
230-51-5S	5	1951-54	580120	580416	1.7	30 - 40	580321	.18-.22
230-51-5D	5	1951-54	580120	580416	1.7	30 - 40	580321	.18-.22
230-55-5D	5	1955	580183	580416	1.7	30 - 40	580321	.18-.22
50-T-3342	5	1956	580120	580416	1.7	30 - 40	580321	.18-.22
50-T-3343	5	1956	580182	580416	1.7	30 - 40	580321	.18-.22
50-T-3343A	5	1956	580182	580416	1.7	30 - 40	580321	.18-.22
50-T-3343B	5	1957	580182	580416	1.7	30 - 40	580321	.18-.22
50-Z-3324	5	1958	580206	580416	1.7	30 - 40	580321	.18-.22
230-50-12	12	1950	580047	580040	1.6	34 - 46	300153	.15-.205
230-51-12D	12	1951-53	580120	580416	1.7	30 - 40	580321	.18-.22
230-51-12S	12	1953	580120	580416	1.7	30 - 40	580321	.18-.22
230-53-12D	12	1954	580153	580416	1.7	30 - 40	580321	.18-.22
50-T-3344	12	1956	580207	580416	1.7	30 - 40	580321	.18-.22

WARD'S - "SEA KING"

Model No.	H. P.	Year	Magneto No.	Coil No.	Operating Amperage	Continuity Min. Max.	Condenser No.	Capacity Microfarads
GG9004A	3	1955	580128	580416	1.7	30 - 40	580321	.18-.22
GG9004B	3	1955	580128	580416	1.7	30 - 40	580321	.18-.22
GG9000A	3	1956	580128	580416	1.7	30 - 40	580321	.18-.22
GG9006A	3	1957	580128	580416	1.7	30 - 40	580321	.18-.22
GG8962A	3	1958	580128	580416	1.7	30 - 40	580321	.18-.22
GG8919A	3	1959	580128	580416	1.7	30 - 40	580321	.18-.22
GG9013A	5	1955	580183	580416	1.7	30 - 40	580321	.18-.22
GG9001C	5	1955-56	580120	580416	1.7	30 - 40	580321	.18-.22
GG9002A	5	1956	580182	580416	1.7	30 - 40	580321	.18-.22
GG9002B	5	1956	580182	580416	1.7	30 - 40	580321	.18-.22
GG9003A	5	1957	580182	580416	1.7	30 - 40	580321	.18-.22
GG8960A	5	1957	580182	580416	1.7	30 - 40	580321	.18-.22
GG8977A	5	1958	580206	580416	1.7	30 - 40	580321	.18-.22
GG8963A	5	1959	580120	580416	1.7	30 - 40	580321	.18-.22
GG8934A	5	1959	580206	580416	1.7	30 - 40	580321	.18-.22
GG9016A	12	1954-55	580153	580416	1.7	30 - 40	580321	.18-.22
GG9016B	12	1956	580207	580416	1.7	30 - 40	580321	.18-.22
GG9016C	12	1957	580207	580416	1.7	30 - 40	580321	.18-.22
GG8978A	12	1957	580207	580416	1.7	30 - 40	580321	.18-.22
GG9021A	12	1956	580207	580416	1.7	30 - 40	580321	.18-.22
GG9021B	12	1956	580207	580416	1.7	30 - 40	580321	.18-.22
GG9024A	12	1956	580207	580416	1.7	30 - 40	580321	.18-.22
GG8971A	12	1957	580207	580416	1.7	30 - 40	580321	.18-.22
GG8971B	12	1957	580207	580416	1.7	30 - 40	580321	.18-.22
GG9005A	12	1957	580207	580416	1.7	30 - 40	580321	.18-.22
GG8978A	12	1958	580207	580416	1.7	30 - 40	580321	.18-.22
GG8981A	12	1958	580254	580416	1.7	30 - 40	580321	.18-.22
GG8935A	12	1959	580254	580416	1.7	30 - 40	580321	.18-.22

WARD'S - "SEA KING" (Cont'd)

Model No.	H. P.	Year	Magneto No.	Coil No.	Operating Amperage	Continuity Min. Max.	Condenser No.	Capacity Microfarads
GG9019A	22	1955	580180	580416	1.7	30 - 40	580321	.18-.22
GG9020A	22	1955	580180	580416	1.7	30 - 40	580321	.18-.22
GG9019B	22	1955	580180	580416	1.7	30 - 40	580321	.18-.22
GG9020B	22	1955	580180	580416	1.7	30 - 40	580321	.18-.22
GG9022A	25	1956	580209	580416	1.7	30 - 40	580321	.18-.22
GG9022B	25	1956	580209	580416	1.7	30 - 40	580321	.18-.22
GG9023A	25	1956	580209	580416	1.7	30 - 40	580321	.18-.22
GG9023B	25	1956	580209	580416	1.7	30 - 40	580321	.18-.22
GG9025A	25	1957	580209	580416	1.7	30 - 40	580321	.18-.22
GG9026A	25	1957	580209	580416	1.7	30 - 40	580321	.18-.22
GG8985A	25	1958	580274	580416	1.7	30 - 40	580321	.18-.22
GG8992A	25	1958	580274	580416	1.7	30 - 40	580321	.18-.22
GG8937A	25	1959	580274	580416	1.7	30 - 40	580321	.18-.22
GG8938A	25	1959	580274	580416	1.7	30 - 40	580321	.18-.22
GG8997A	35	1958	580333	580197	1.4	42 - 52	580321	.18-.22
GG8942A	35	1959	580333	580197	1.4	42 - 52	580321	.18-.22
GG8952A	35	1959	580333	580197	1.4	42 - 52	580321	.18-.22
GG8942B	35	1959	580333	580197	1.4	42 - 52	580321	.18-.22
GG8952B	35	1959	580333	580197	1.4	42 - 52	580321	.18-.22

WARD'S - "SEA KING" (Cont'd)

Model No.	H. P.	Year	Magneto No.	Coil No.	Operating Amperage	Continuity No.	Condenser No.	Capacity
GG8804A	3	1960	580128	580416	1.7	30 - 45	580321	.18- .22
GG8822A	5	1960	580206	580416	1.7	30 - 45	580321	.18- .22
GG8823A	15	1960	580270	580197	1.4	42 - 52	580422	.25- .29
GG8834A	25	1960	580274	580416	1.7	30 - 45	580321	.18- .22
GG8835A	25	1960	580274	580416	1.7	30 - 45	580321	.18- .22
GG8836A	35	1960	580307	580197	1.4	42 - 52	580422	.25- .29
GG8837A	35	1960	580307	580197	1.4	42 - 52	580422	.25- .29
-	60	1960	580319	580243	1.7	40 - 55	580256	.37- .41
GG8850A	60	1960	580319	580243	1.7	40 - 55	580256	.37- .41
GG18735A	3	1961	580128	580416	1.7	40 - 55	580321	.18- .22
GG18736A	5	1961	580206	580416	1.7	40 - 55	580321	.18- .22
GG18736B	5	1961	580206	580416	1.7	40 - 55	580321	.18- .22
GG18736C	5	1961	580206	580416	1.7	40 - 55	580321	.18- .22
GG18737A	15	1961	580270	580197	1.4	42 - 52	580422	.25- .29
GG18737B	15	1961	580270	580197	1.4	42 - 52	580422	.25- .29
GG18738A	25	1961	580274	580416	1.7	30 - 45	580321	.18- .22
GG18740A	25	1961	580274	580416	1.7	30 - 45	580321	.18- .22
GG18738B	25	1961	580274	580416	1.7	30 - 45	580321	.18- .22
GG18740B	25	1961	580274	580416	1.7	30 - 45	580321	.18- .22
GG18742A	40	1961	580333	580197	1.4	42 - 52	580321	.18- .22
GG18744A	40	1961	580333	580197	1.4	42 - 52	580321	.18- .22
-	60	1961	580319	580243	1.7	40 - 55	580256	.37- .41
GG18746A	60	1961	580319	580243	1.7	40 - 55	580256	.37- .41
-	60	1961	580319	580243	1.7	40 - 55	580256	.37- .41
GG18748A	60	1961	580319	580243	1.7	40 - 55	580256	.37- .41
GG18735B	3	1962	580128	580416	1.7	30 - 45	580321	.18- .22
GG18736D	5	1962	580206	580416	1.7	30 - 45	580321	.18- .22
GG18737C	15	1962	580434	580416	1.7	30 - 45	580422	.25- .29
GG18737D	15	1962	580254	580416	1.7	30 - 45	580321	.18- .22
GG18738C	25	1962	580274	580416	1.7	30 - 45	580321	.18- .22
-	25	1962	580274	580416	1.7	30 - 45	580321	.18- .22
GG18742B	40	1962	580415	580416	1.7	30 - 45	580422	.25- .29

WARD'S - "SEA KING" (Cont'd)

Model No.	H. P.	Year	Magneto No.	Coil No.	Operating Amperage	Continuity No.	Condenser No.	Capacity
GG18744B	40	1962	580415	580416	1.7	30 - 45	580422	.25- .29
GG18746C	60	1962	580319	580243	1.7	40 - 55	580256	.37- .41
GG18748C	60	1962	580319	580243	1.7	40 - 55	580256	.37- .41

WARD'S - SEA KING MOTORS

Model	Coil No.	Operating Amperage	Secondary Continuity Min. Max.	Condenser No.	Capacity Microfarads Min. Max.
19068	X12940	1.4	50 - 60	X12174	.16- .20
19072	X11406	2.1	40 - 60	X11397	.16- .20
19076	X11406	2.1	40 - 60	X11397	.16- .20
19084	X14381	1.4	50 - 60	X12303	.16- .20
19088-					
19089	LX2477	1.5	40 - 60	S2433	.28- .36
19088A-					
19089A	TX2477	1.5	45 - 55	S2433	.28- .36
19092-					
19093	X11563	0.75	40 - 60	X11337	.26- .30
19096	X11563	0.75	40 - 60	X12647	.26- .30

WESTERN AUTO - WIZARD MOTORS

Wizard No.	Model No.	H. P.	Mfg.	Coil No.	Wizard No.	Oper. Amps	Primary Resistance Min.Max.	Secondary Resistance Min.Max.	Condenser Mfg. No.	Wizard No.	Capacity Micro. Min.Max.
MLM-6903A	A7BB	3.6	Phelon	FG3689	1380134	2.5		40 - 60	Phelon FG3693	1380115	.15- .19
MLM-6908A	A7EB	7.5	McCul		1340134	2.5		40 - 60	Wico X12293	1340115	.18- .22
	C7EB										
MLM-6912A	A7FB	12.0	Phelon	FG4128	1390134	2.5		40 - 55	Phelon FG3693	1380115	.15- .19
MLM-6930A	A7GB	25.0	Wico	X11352	36850113	2.0		40 - 60	Wico X11362	36850115	.26- .30
MLM-6932A	C7GB		McCul	4368-134	76096-Top	1.4	.55- .85	45 - 60	Wico X11362	36850115	.26- .30
MLM-6933A	D7GB		McCul	3368-134	76095-Bot.	1.4	.55- .85	45 - 60	Wico X11362	36850115	.26- .30
MLM-6944A	C7HB	40.0	McCul	4368-134	76096	1.4	.55- .85	45 - 60	Wico X12264	76067	.26- .30
MLM-6945A	D7HB										
MLM-6960A	C7JB	60.0	McCul	C3JB-232	76159	1.4	.55- .85	45 - 60		76066	.25- .27
MLM-6961A	D7JB		McCul	C3JB-232	76159	1.4	.55- .85	45 - 60		76066	.25- .27
MLM-6960B	C7JBI	60.0									
MLM-6961B	D7JBI										
Year - 1961											
MLM-6903B	61700310	3.6	Phelon	FG3689	1380134	2.5		40 - 60	Phelon FG3693	1380115	.15- .19
MLM-6908C	61700710	7.5	Phelon	FG6001	76088	2.5		45 - 60	Phelon FG4477	76065	.15- .19
Year - 1962											
MLM-6903C	62700310	3.6	Phelon	FG6001	76088	2.5		45 - 60	Phelon FG4477	76065	.15- .19
MLM-6914	62701410	14.0	Phelon	FG4128	1390134	2.5		40 - 55	Phelon FG3693	1380115	.15- .19
Year - 1963											
MLM-6904B	64700310	3.5	Phelon	FG3689	1380134	2.5		40 - 60	Phelon FG3693	1380115	.15- .19
MLM-6909B	64700710	7.5	Phelon	FG6001	76088	2.5		45 - 60	Phelon FG4477	76065	.15- .19
MLM-6915B	64701410	14.0	Phelon	FG4128	1390134	2.5		40 - 55	Phelon FG3693	1380115	.15- .19
Year - 1964											
MLM-6904B	64700310	3.5	Phelon	FG3689	1380134	2.5		40 - 60	Phelon FG3693	1380115	.15- .19
MLM-6909B	64700710	7.5	Phelon	FG6001	76088	2.5		45 - 60	Phelon FG4477	76065	.15- .19
MLM-6915B	64701410	14.0	Phelon	FG4128	1390134	2.5		40 - 55	Phelon FG3693	1380115	.15- .19

STIHL CHAIN SAW COIL SPECIFICATIONS

Coil No.	Stihl #	Operating Amperage	Secondary Continuity Min. Max.
9800B	1106-404-3210	1.3	40 - 50
1080	1107-404-3200	1.2	50 - 60
13800	07-08-040	1.5	45 - 55

STIHL CHAIN SAW CONDENSER SPECIFICATION

Condenser No.	Capacity Reading in Microfarads Min. Max.
980114- .18
1080011- .15

WICO MAGNETO COILS SPECIFICATIONS

Coil No.	Type	Operating Amperage	Secondary Continuity
IFAX-103	F. Right Hand	1.40	
IKBX-103	EK-Right Hand	1.60	35 - 55
IXDX-103	OC-Right Hand	1.35	
IFAX-104	F. Left Hand	1.40	
IKBX-104	EK-Left Hand	1.60	35 - 55
IXDX-104	OC-Left Hand	1.35	
18-X123C	FGB-Left Hand	1.50	
18-X123D	FGB-Right Hand	1.50	
X1910	AH-All Models	1.50	45 - 65
X2005	AP	1.40	
X2156	FW	1.50	30 - 50
X2631	OC-Right Hand-HD	1.40	40 - 60
X2632	OC-Left Hand-HD	1.40	40 - 60
X2766	A & C All Models	2.10	35 - 55
X2770	AP	1.50	50 - 70
X2770B	APH	1.90	50 - 70
X2937	O. FW	2.40	
X3040	FW	2.80	
X3040A, B, C, D	FW	1.50	50 - 70
X3430	Q. EM	1.40	
X3682	J & JEM	1.40	45 - 65
X4366B	O. R.E.M.	1.30	
X4658	FW	1.90	40 - 60
X4658B	FW	1.55	40 - 60
X4791	FW	2.30	50 - 70
X4943	FW	1.50	35 - 55
X5345	FW	1.50	40 - 60
X5460C	FW	1.50	30 - 50
X5700 & 5700C	XH	1.70	40 - 60
X5700B		1.70	40 - 60
X5953	FW	2.20	40 - 60
X6111	FW	1.60	35 - 55
*X6664	O. XH-2D Use X11600		
X6718	FW	1.80	40 - 60
X6762	XH-1-Xh-1295 B & C only	2.50	40 - 60
X6872B	XB-Short Lead to GRD.	1.40	45 - 65
X6877B	O. XB	2.10	
X6933	O. FW	1.45	
X6936	XHD4 and XVD6	1.75	
X6985	FW	1.50	35 - 55
X7120	FW	1.40	30 - 50
X7233	FW	1.80	40 - 60
X7325	FW	1.70	40 - 60
X7345	FW	1.70	35 - 55
X7438	FW	1.80	40 - 60
X7453	O. FW Use X4658B	1.55	
X7467	FW	1.80	30 - 50
X7500	FW	2.10	30 - 50
X7536	FW	1.90	38 - 58
X7560	O. FW	1.70	
X7585	O. XHD-1	2.30	
X7680	FW	1.80	
X7700	O. RES	1.90	
X7744	O. XH	1.70	
X7886B	XH1	2.20	30 - 50
X7895B	SHX-2D	2.60	45 - 65
X7895C		1.6	60 - 70

WICO MAGNETO COIL SPECIFICATIONS (Cont'd)

Coil No.	Type	Operating Amperage	Secondary Continuity
X8545	XH1	2.00	40 - 60
X8668	FW	1.70	40 - 60
X8786	FW	1.80	30 - 50
X8795	FW	1.80	30 - 50
X8798	XB	2.20	45 - 65
X8877	FW	2.00	
*X8964	O. XH-2D Use X11600	2.30	
X9055	FW	2.10	35 - 55
X9144	FW	1.60	50 - 70
X9295	B (center core only)	2.30	35 - 55
X9295	B (On stator both cores)	2.10	35 - 55
X9533	FW	2.20	30 - 50
X9636B		1.55	45 - 55
X9692	FW	2.30	35 - 55
X9697	O. FW	2.30	
X9767	FW	1.80	35 - 55
X9965	FW	1.8	40 - 55
X11049	FW	1.85	30 - 50
X11135		2.0	45 - 60
X11180	FW	1.80	40 - 55
X11205		2.0	40 - 55
X11260	FW	1.8	40 - 55
X11352		2.00	40 - 60
X11406		2.10	40 - 60
X11477		2.00	40 - 60
**X11563 (German Bosch #TJ 12/1 or TK12A3)		0.75	40 - 60
*X11600 (X6664 & X8964)		1.90	40 - 60
X11654		2.1	40 - 55
X11856		1.8	40 - 55
X12254		1.8	45 - 60
X12302		2.2	40 - 55
X12325		1.8	40 - 55
X14171B	FW	1.3	50 - 60
X15043	FW	2.8	50 - 70
X16343	FW	1.3	50 - 60
X16669		1.3	50 - 60
X16797		1.8	50 - 60
X16809		1.3	50 - 60
X16825	FW	1.3	50 - 60

Wico (Green) XH-1 (Replaced by X5700)

*Ground one lead.

**When testing coil X11563 (German Bosch #TJ 12/1 or TK 12A3), disconnect the Internal Battery and connect Analyzer Leads to a 12 Volt Storage Battery by attaching our Part No. 55-174 in series with one side of the Battery Lead. DO NOT use the 12 volts for any other tests.

WICO MAGNETO CONDENSER SPECIFICATIONS

Condenser	Magneto	Capacity Reading in Microfarads	
		Min.	Max.
12-X235	EK, OC, Old Style	.10-	.15
X1413	A, C, J, JEM.	.16-	.20
X2186	FW	.16-	.20
X2394	FG	.20-	.22
X2413	AP-Left Hand	.16-	.20
X2414	AP	.20-	.24
X2664	FG	.16-	.20
X2981	FW	.16-	.20
X3222	EM	.16-	.20
X3517	AP-Right Hand	.16-	.20
X4034	FW	.16-	.20
X4215	FW	.16-	.20
X5321	FW	.16-	.20
X5342	FW	.30-	.34
X5463	FW	.16-	.20
X5614	XH, XV	.16-	.20
X5800	FW	.16-	.20
X5833	FW	.16-	.20
X5847	FW	.16-	.20
X5999	A, C, J, JEM.	.16-	.20
X6028	FW	.16-	.20
X6029	EM	.16-	.20
X6030	FW	.16-	.20
X6091	FW	.16-	.20
X6138	APH	.30-	.34
EX6367	Edison, RM-2, 4, 6	.16-	.20
EX6369	Edison, RM-1, 2	.16-	.20
X6494	EK, OC	.16-	.20
X6874	XB	.30-	.34
X6916	XHD, XVD	.30-	.34
X6937		.16-	.20
X6977	XB	.30-	.34
EX6980	RM	.16-	.20
X7228	FW	.16-	.20
X7331	FW	.10-	.15
X7372	FW	.30-	.34
X7461	FW	.10-	.15
X7529	FW	.16-	.20
X7720	XHS	.16-	.20
X8680	XHS-1, XHS-2	.16-	.20
X8807	FW	.30-	.34
X8959	FW	.16-	.20
X9100	FW	.26-	.30
X9106	FW	.18-	.23
X9182	FW	.26-	.30
X9263	B	.30-	.34
X9293	XVS	.26-	.30
X9327	FW	.26-	.30
X9451	FW	.16-	.20
X9686	XHS-1	.18-	.20
X9699	XHS	.26-	.30
X10400	REM	.18-	.23
X11000	FW	.16-	.23
X11181	FW	.16-	.20
X11206		.30-	.34
X11264		.26-	.30

WICO MAGNETO CONDENSER SPECIFICATIONS (Cont'd)

Condenser	Magneto	Capacity Reading
		in Microfarads Min.,Max.
X11337		.26- .30
X11362		.26- .30
X11397		.16- .20
X11672		.16- .20
X11818		.58- .62
X12174		.16- .20
X12264		.26- .30
X12293		.18- .22
X12302		.16- .20
X12303		.16- .20
X12508		.16- .20
X12513		.16- .20
X12647		.16- .20
X12984		.30- .34
X13299		.16- .20
X14497		.16- .20
X14590		.24- .28
X14680	SHX	.30- .34
X15041	FW	.16- .20
X16264	FW	.16- .20
X16329	FW	.16- .20
X16345	FW	.16- .20
X16410	FW	.16- .20
X30028	DB	.18- .23
X30028B	DB	.18- .23
X30188	DB (12 volt)	.30- .34
X30280		.26- .30
X30280B		.26- .30

WISCONSIN MOTOR CORPORATION

Engine Model	Magneto Mfgr.	Magneto No.	Coil No.	Operating Amperage	Continuity Min. Max.	Condenser No.	Microfarad Capacity
VR4D	F-M	X4A7B	R-2477C	1.70	40 - 60	AX-M-R2433	.18- .23
VG4D	F-M	XZE4B7	RS-2477C	1.70	40 - 60	MX2433X	.28- .35
	F-M	X4B7A	R-2477C	1.70	40 - 60	AX-M-R2433	.18- .23
VP4D	Wico	XH4	X5700	1.70	40 - 60	X5614	.16- .20
	F-M	ZV4B7	QS-2477C	1.65	40 - 65	SYX2433	.28- .33
	F-M	ZVE4B7	QS-2477C	1.65	40 - 65	EX2433	.17- .23
VH4	Wico	XH4	X5700	1.70	40 - 60	X5614	.16- .20
	Wico	XHG4	X5700	1.70	40 - 60	X5614	.16- .20
VE4 & VF4	F-M	X4B7A	R-2477C	1.50	40 - 60	AX-M-R2433	.18- .23
	F-M	XZE4B7	RS-2477C	1.70	40 - 60	MX2433X	.28- .35
	Wico	XH4	X5700	1.70	40 - 60	X5614	.16- .20
MVH4D TH & THD	F-M	ZV4B7	QS-2477C	1.65	40 - 65	SYX2433	.28- .33
	F-M	ZVE4B7	QS-2477C	1.65	40 - 65	EX2433	.17- .23
	F-M	XZE4B7	RS-2477C	1.70	40 - 60	MX2433X	.28- .35
TE & TF	Wico	XH-20	X11600	1.90	40 - 60	X6916	.30- .34
	F-M	X1-2B7	Q2477C	1.70	50 - 70	X2433	.17- .23
	F-M	XE1-2B7C	Q2477C	1.70	50 - 70	X2433	.17- .23
AEN & AENS	Wico	XH-2D	X11600	1.90	40 - 60	X6916	.30- .34
	F-M	X1-2B7	Q2477C	1.70	50 - 70	X2433	.17- .23
	F-M	XE1-2B7C	Q2477C	1.70	50 - 70	X2433	.17- .23
AENL	Wico	XH1	X5700	1.70	40 - 60	X6916	.30- .34
	F-M	XD1B7S	X6762	2.50		X5614	.16- .20
	F-M	XD1B7S	S-2477C	1.70	50 - 60	AX-M-R2433	.18- .23
	F-M	XD1B7U	S-2477C	1.70	50 - 60	SYX-2433	.28- .33
	F-M	XDE1B7S	S-2477C	1.70	50 - 60	SYX-2433	.28- .33
AENL	F-M	XDE170	S-2477C	1.70	50 - 60	SYX-2433	.28- .33
	Wico	XH1	X5700B	1.70	40 - 60	X6916	.30- .34
	F-M	XD1B7S	S-2477C	1.70	50 - 60	AX-M-R2433	.18- .23
	F-M	XD1B7U	S-2477C	1.70	50 - 60	AX-M-R2433	.18- .23
AENL	F-M	XDE1B7S	S-2477C	1.70	50 - 60	SYX2433	.28- .33
	F-M	XE17U	S-2477C	1.70	50 - 60	SYX2433	.28- .33

WISCONSIN MOTOR CORPORATION (Cont'd)

Engine Model	Magneto Mfr.	Magneto No.	Coil No.	Operating Amperage	Continuity Min. Max.	Condenser No.	Microfarad Capacity
AF & AG & AH	Wico	XH1	X5700	1.70	40 - 60	X6916	.30-.34
	Wico	XH1	X6762	2.50		X5614	.16-.20
AD-AE-AES	F-M	J1A7	L-2477	1.80	35 - 55	M2433	.18-.22
	Wico	XH-1	X5700	1.70	40 - 60	X6916	.30-.34
	Wico		X6762	2.50		X5614	.16-.20
	F-M	J1A7	L-2477	1.80	35 - 55	M2433	.18-.22
	F-M	X1A7	L-2477C	1.80	35 - 55	R-2433	
	AGN	Wico	XH1	X5700B	1.70	40 - 60	X6916
AFH & AGH & AHH	F-M	XD1B7R	T-2477C	1.90	40 - 60	AX-M-R2433	.18-.23
	F-M	PE1B7R	T-2477C	1.90	40 - 60	SXY2433	.28-.33
	Wico	XH-1	X6762	2.50		X6916	.30-.34
	Wico	XH-1	X5700	1.70	40 - 60	X5614	.16-.20
	F-M	XE1A7F	S-2477C	1.90	45 - 65	AX-M-R2433	.18-.23
	F-M	XD1B7	S-2477C	1.90	45 - 65	AX-M-R2433	.18-.23
	F-M	X1A7	T-2477C	1.90	40 - 60	AX-M-R2433	.18-.23
	F-M	XE1A7F	T2477C	1.90	40 - 60	AX-M-R2433	.18-.23
	F-M	X1B7E	T-2477C	1.90	40 - 60	AX-M-R2433	.18-.23
	ADH & AE & AEH & AEHS	Wico	XH1	X6762	2.50		X6916
ACN & BKN	Wico	XH1	X5700	1.70	40 - 60	X5614	.16-.20
	F-M	XD1B7	S-2477C	1.90	45 - 65	R2433	.18-.23
	F-M	XDE1B7P	S-2477C	1.90	45 - 65	AX-M-R2433	.18-.23
	F-M	X1A7	S-2477C	1.90	45 - 65	AX-M-R2433	.18-.23
	F-M	XE1A7E	S-2477C	1.90	45 - 65	AX-M-R2433	.18-.23
	F-M	X1B7E	S-2477C	1.90	45 - 65	AX-M-R2433	.18-.23
	Wico	XH1	X6762	2.50		X6916	.30-.34
						X5614	.16-.20

WISCONSIN MOTOR CORPORATION (Cont'd)

Engine Model	Magneto Mfgr.	Magneto No.	Coil No.	Operating Amperage	Continuity Min. Max.	Condenser No.	Microfarad Capacity	
AA & AB & ABS & ABN & AK & AKS & AKN	F-M	XD1B7S	S-2477C	1.90	45 - 65	AX-M-R2433	.18-.23	
	F-M	XD1B7U	S-2477C	1.90	45 - 65	AX-M-R2433	.18-.23	
	F-M	XDE1B7S	S-2477C	1.90	45 - 65	SYX-2433	.28-.33	
	F-M	XDE17U	S-2477C	1.90	45 - 65	SYX-2433	.28-.33	
	Wico	XH1	X5700	1.70	40 - 60	X6916	.30-.34	
	Wico	XH1	X6762	2.50		X5614	.16-.20	
	F-M	XD1B7	H-2477C	1.90	45 - 65	R2433	.17-.23	
	F-M	XD1B7D	H-2477C	1.90	45 - 65	R2433	.17-.23	
	F-M	XDE1B7P	H-2477C	1.90	45 - 65	R2433	.17-.23	
	F-M	X1A7	L-2477C	1.80	35 - 55	R2433	.17-.23	
	F-M	X1A7E	L-2477C	1.80	35 - 55	R2433	.17-.23	
	F-M	X1A7F	L-2477C	1.80	35 - 55	R2433	.17-.23	
	F-M	XE1A7F	L-2477C	1.80	35 - 55	R2433	.17-.23	
	F-M	J1A7	L-2477	1.80	35 - 55	M2433	.18-.22	
	F-M	J1B7	L-2477	1.80	35 - 55	M2433	.18-.22	
	MTHD	Wico	XHS-2D	X7895	2.60		X7720	.16-.20
	MTFD	F-M	PE1-2B7C	QT-2477C	1.70	40 - 65	LV-2433	.38-.43
Wico		XHS-2D	X7895	2.60		X7720	.16-.20	
MVE4D & MVF4D	F-M	XVE4B7Q	H-2477	1.70	40 - 60	S2433	.28-.32	
TFM	F-M	ZVE4B7	QS-2477C	1.65	40 - 65	EX2433	.17-.23	
	Wico	XH-2D	X6664	2.30		X6916	.30-.34	
ABM & AKM						X5614	.16-.20	
	F-M	JF2B7	G2477	1.55		M2433	.18-.22	
	F-M	X1A7E	H-2477C	1.90	40 - 65	R2433	.17-.23	
	F-M	XD1B7D	H-2477C	1.90	40 - 65	R2433	.17-.23	

INDEX

Armature Ground Test	17
Automotive Type Coils	10
Breaker Point Test	15
Coil Continuity Test	8
Coil Ground Test	9
Coil Power Test	5
Coil High Speed Test	6
Coil Surface Insulation Test	7
Condenser Test	11-12-13-14-16
Continuity Test	19
Description, Service Notes and Operating Instructions	1-4
Distributor Rotor Test	22
Evinrude-Johnson Uni-charger or AC Generator - "Alternator"	27-40
Field Winding Ground Test	25
Ground Armature or Field Winding	26
Ground Brush Test	25
High Tension Leakage-Crack Test	21
Primary Resistance Test	8A
Resistance Test	19
Resistor or Ballist Test	20
Service Hints	43-44
Spark Test	18
Starter Solenoid Test	18
Testing Coil with Two Secondary	23
Testing Conventional Type Magnets	23
Testing Selenium Rectifiers	24
Timing	16-17

COIL AND CONDENSER SPECIFICATIONS

AMC	45
Atlas	46
Auto-lite	47
Bandix-Scintilla	48
American Bosch	51
German Bosch	54
Robert Bosch	54-55
Briggs & Stratton	56
British Seagull	57
Bridgestone	57
Bundy	58
J. I. Case	58
Chrysler	59-66
Clinton	67
Commodore	68
Continental	68
Cushman	69

INDEX - cont'd.

Delco-Remy	69
Eaton-Volvo	69
Echlin	70
Edison Splitdorf	70
Eisemann	71-74
Elgin	110-114
Evinrude - See Johnson	
Fairbanks-Morse	75-76
Ford - See Auto-Lite	
Gale	77-81
Gambles	82
Goodyear	83-84
Homelite	84-85
Honda	85
International Harv.	85
John Deere	85
Johnson	86-87
Kiekhaefer-Mercury	88
Kohler	89
Lauson	90-91
Lawn Boy	91
Mallory	92
McCulloch	93-104
Oliver	106
O & R	106
Oran (Division of Studebaker)	105
OMC - See Johnson	
Phelon	107-108
Pioneer	109
Pioneer-Genie	109
Polaris - See German Bosch	
Prestolite - See Auto-Lite	
Ronco	109
Sears	110-116
Ski-Doo - See German Bosch	
Spiegel	117-118
Stihl Chain Saw	124
Wards-Sea-King	119-122
West Bend - See Chrysler	
Western Auto	123
Wico	125-128
Wisconsin Mtr.	129-131



1970 BULLETIN

AMERICAN BOSCH COIL SPECIFICATIONS

Coil No.	Operating Amperage	Primary Resistance		Secondary Continuity	
		Min.	Max.	Min.	Max.
TCF 12 A 1	1.5	10	14	52	62

ANDOVER CORPORATION COIL SPECIFICATIONS

Coil No.	Operating Amperage	Primary Resistance		Secondary Continuity	
		Min.	Max.	Min.	Max.
A316475	1.0	1.7	2.3	65	75
A85475-1	1.0	1.6	2.0	63	72
A85475-2	1.0	1.6	2.0	63	72
****A91475-1	1.0	3.0	3.6	50	60
****2A91475-2	1.2	3.0	4.0	53	63

****To test coil, disconnect the internal battery and connect leads to a 12 volt storage battery. Do not use the 12 volts for any other tests as all other readings will be incorrect.

BENDIX SCINTILLA COIL SPECIFICATIONS

Coil No.	Operating Amperage	Secondary Continuity	
		Min.	Max.
10-160396	1.8	30	40

BENDIX SCINTILLA CONDENSER SPECIFICATIONS

Condenser No.	Capacity Reading in Microfarads	
	Min.	Max.
10-79168Y	.18	.23
10-126216	.27	.31

BOMBARDIER (SKI-DOO) COIL & CONDENSER SPECIFICATIONS

Application	Year	Description and Number	Operating Amperage	Primary Resistance		Secondary Continuity		Resistance	Capacity Reading In Microfarads	
				Min.	Max.	Min.	Max.		Min.	Max.
****7 H.P. (165 C.C.)	63-66 incl.	Ignition #402-4038	1.0	1.8	2.1	35	45	.4	.13	.17
7 H.P. (165 C.C.)	63-66 incl.	Lighting #402-4083								
7 H.P. (165 C.C.)	63, 64, 65	Condenser #402-4067								
****8 H.P. (250 C.C.)	63-66 incl.	Ignition #402-4040	1.0	1.5	1.9	40	50	.7	.26	.30
8 H.P. (250 C.C.)	63-66 incl.	Lighting #402-4084								
8 H.P. (250 C.C.)	63-66 incl.	Condenser #402-4068								
****165 C.C.	67	Ignition #402-4038	1.0	1.8	2.1	35	45	.4	.13	.17
165 C.C.	67	Lighting #402-4083								
165 C.C.	67	Condenser #402-4067								
****250-300 C.C.	67	Ignition #402-4040	1.0	1.5	1.9	40	50	.7	.26	.30
250-300 C.C.	67	Lighting #402-4084								
250-300 C.C.	67	Condenser #402-4068								
Alpine 300-370 C.C.	67	Lighting #402-7015						1.0		
Alpine 300-370 C.C.	67	Generator #402-7013						1.25		
Alpine 300-370 C.C.	67	Condenser #402-4068							.26	.30
****250-300 Alpine 300 C.C.	68	Ignition #402-4040	1.0	1.5	1.9	40	50	.7	.26	.30
250-300 Alpine 300 C.C.	68	Lighting #402-4084								
250-300 Alpine 300 C.C.	68	Condenser #402-4068								
****Olympique 370	68	Ignition #402-7008	.6	1.6	2.0	35	45	1.0	.26	.30
Olympique 370	68	Lighting #402-7015								
Olympique 370	68	Generator #402-7013								
Olympique 370	68	Condenser #402-4068								
****Olympique 370E-Alpine 370E	68	Ignition #402-7008	.6	1.6	2.0	35	45	1.35	.26	.30
Olympique 370E-Alpine 370E	68	Lighting #402-4107								
Olympique 370E-Alpine 370E	68	Generator #402-7013								
Olympique 370E-Alpine 370E	68	Condenser #402-4068								
****Olympique 300-320-292 (12/3SS)335 (320 SS)	69	Ignition #402-4040	1.0	1.5	1.9	40	50			

BOMBARDIER (SKI-DOO) COIL & CONDENSER SPECIFICATIONS (Cont.)

Application	Year	Description and Number	Operating Amperage	Primary Resistance		Secondary Continuity		Resistance	Capacity Reading In Microfarads	
				Min.	Max.	Min.	Max.		Min.	Max.
Olympique 300-320-292 (12/35S)335 (320 SS)	69	Lighting #402-4084						.7		
Olympique 300-320-292 (12/35S)335 (320 SS)	69	Condenser #402-4068							.26	.30
****Olympique 320E	69	Ignition #402-7008	.6	1.6	2.0	35	45			
Olympique 320E	69	Lighting #402-4084						.7		
Olympique 320E	69	Generator #402-7063						3.5		
Olympique 320E	69	Condenser #402-4068							.26	.30
****Olympique 370-Alpine 370-370E	69	Ignition #402-7008	.6	1.6	2.0	35	45			
Olympique 370-Alpine 370-370E	69	Lighting #402-4107						1.35		
Olympique 370-Alpine 370-370E	69	Generator #402-4180						3.5		
Olympique 370-Alpine 370-370E	69	Condenser #402-4068							.26	.30
****Nordic 371-371E, Alpine 640E, TNT 399-699	69	Ignition #402-7008	.6	1.6	2.0	35	45			
Nordic 371-371E, Alpine 640E, TNT 399-699	69	Lighting #402-4155						1.7		
Nordic 371-371E, Alpine 640E, TNT 399-699	69	Generator #402-4150 L.H. Winding Top						3.0		
Nordic 371-371E, Alpine 640E, TNT 399-699	69	Generator #402-4151 R.H. Winding Bottom						3.0		
Nordic 371-371E, Alpine 640E, TNT 399-699	69	Condenser #402-4068							.26	.30
****Olympique 335D	70	Ignition #402-7008	.6	1.6	2.0	35	45			
Olympique 335D	70	Generator #402-7063						3.5		
Olympique 335D	70	Condenser #402-4068							.26	.30
****Olympique 399, Nordic 399-399E - 640 Alpine 399-399E-640E, TNT 399-640-775	70	Ignition #402-7008	.6	1.6	2.0	35	45			

BOMBARDIER (SKI-DOO) COIL & CONDENSER SPECIFICATIONS (Cont.)

Application	Year	Description and Number	Operating Amperage	Primary Resistance		Secondary Continuity		Resistance	Capacity Reading In Microfarads	
				Min.	Max.	Min.	Max.		Min.	Max.
Olympique 399, Nordic 399-399E-640 Alpine 399-399E-640E, TNT 399-640-775	70	Lighting #402-4155						1.7		
Olympique 399, Nordic 399-399E-640 Alpine 399-399E-640E, TNT 399-640-775	70	Generator #402-4150 L.H. Winding Top						3.0		
Olympique 399, Nordic 399-399E-640 Alpine 399-399E-640E, TNT 399-640-775	70	Generator #402-4151 R.H. Winding Bottom						3.0		
Olympique 399, Nordic 399-399E-640 Alpine 399-399E-640E, TNT 399-640-775	70	Condenser #402-4068							.26	.30
****Olympique 300-335, TNT 292-340	70	Ignition #402-4040	1.0	1.5	1.9	40	50			
Olympique 300-335, TNT 292-340	70	Condenser #402-4068							.26	.30
****Blizzard 292-340	70	Ignition #402-7008	.6	1.6	2.0	35	45			
Blizzard 292-340	70	Lighting #402-4155						1.7		
****Blizzard 436-636-776	70	Ignition #402-7008	.6	1.6	2.0	35	45			
Blizzard 436-636-776	70	Lighting #402-4155						1.7		

****NOTE: When testing above coils, disconnect the 7-1/2 volt internal battery and connect leads to a 12 volt storage battery for coil power test only.

BRIGGS & STRATTON CORPORATION SPECIFICATIONS

Coil No.	Operating Amperage	Primary Resistance		Secondary Continuity	
		Min.	Max.	Min.	Max.
**298502	1.6	.2	.3	25	35

** Correction to Operational Manual, page 56

BRITISH SEAGULL COIL SPECIFICATIONS

Coil No.	Operating Amperage	Primary Resistance		Secondary Continuity	
		Min.	Max.	Min.	Max.
5 4136	1.25	.7	1.3	40	50

CUSHMAN MOTORS COIL SPECIFICATIONS

Coil No.	Operating Amperage	Primary Resistance		Secondary Continuity	
		Min.	Max.	Min.	Max.
383444	1.0	1.2	1.6	50	60
*580883	1.45	.8	1.2	20	30

*To check this coil, use C. D. Adaptor, #55-980.

DELCO-REMY COIL SPECIFICATIONS

Coil No.	Operating Amperage	Secondary Continuity	
		Min.	Max.
1115043	.55	39	48

DELCO-REMY CONDENSER SPECIFICATIONS

Condenser No.	Capacity Reading In Microfarads	
	Min.	Max.
1965489	.18	.23
**1942948	.27	.31

**Secondary continuity changed from Operational Manual, page 69. (Condenser listed as 194948 in error, should be 1942948.)

CHRYSLER OUTBOARD CORPORATION COIL SPECIFICATIONS

Chrysler Part No.	Operating Amperage	Primary Resistance		Secondary Continuity		Mfg.	Mfg. No.
		Min.	Max.	Min.	Max.		
12057	1.5	.62	.68	45	55	Fairbanks-Morse	TX2477
12211	1.5	.50	.65	50	60	Wico	X12940
12226	1.4	.48	.54	50	60	Wico	X14381
A12231	1.4	.48	.54	50	60	Wico	X14877
A316475	1.0	1.7	2.3	65	75	Andover	
*321475-1	2.35	too low to read		10	14		
*345475-1	1.7	.2	.24	7	11	Motorola	70C44882B02
**A85475-1	1.0	1.6	2.0	63	72	Andover	
A85475-2	1.0	1.6	2.0	63	72	Andover	
****A91475-1	1.0	3.0	3.6	50	60	Andover	
****2A91475-2	1.2	3	4	53	63	Andover	

CHRYSLER OUTBOARD CORPORATION CONDENSER SPECIFICATIONS

Chrysler No.	Capacity Reading In Microfarads		Mfg.	Mfg. No.
	Min.	Max.		
12042	.28	.33	Fairbanks-Morse	FS 2433
12117	.16	.20		
12119	.26	.30		
12139	.26	.30	Wico	X11337
12143	.16	.20	Wico	X11397
12178	.16	.20	Wico	X12174
12181	.16	.20	Wico	X12303
12196	.26	.30		
14022-1	.36	.44	Mallory	

*When testing this coil, use C. D. Adaptor #55-980.

**Change from manual page 64, should be tested with 7-1/2 volt battery.

****To test coil, disconnect the internal battery and connect leads to 12 volt storage battery. Do not use the 12 volts for any other tests as all other readings will be incorrect.

JACOBSEN COIL SPECIFICATIONS

Coil No.	Mfg. No.	Operating Amperage	Secondary Continuity	
			Min.	Max.
107897	FG 4081	2.8	40	60
	X16797	1.8	50	60
314303	FG 32948	2.8	40	60
324094	X12935	1.7	50	60

JACOBSEN CONDENSER SPECIFICATIONS

Condenser No.	Mfg. No.	Capacity Reading In Microfarads	
		Min.	Max.
314305	FG 3723	.16	.18

KIEKHAEFER-MERCURY COIL SPECIFICATIONS

Coil No.	Mfg. No.	Mfg.	Operating Amperage	Primary Resistance		Secondary Continuity	
				Min.	Max.	Min.	Max.
398-2568 1A	FG 72028	Phelon	1.6	.47	.57	45	55

FISHER-PIERCE COIL SPECIFICATIONS

Coil No.	Operating Amperage	Primary Resistance		Secondary Continuity	
		Min.	Max.	Min.	Max.
90098-P1	.95	1.5	1.7	60	70

FISHER-PIERCE CONDENSER SPECIFICATIONS

Condenser No.	Mfg. No.	Capacity Reading In Microfarads	
		Min.	Max.
1AT3076T	P2-45	.20	.26

GALE PRODUCTS
OMC COIL SPECIFICATIONS

Coil No.	Operating Amperage	Primary Resistance		Secondary Continuity	
		Min.	Max.	Min.	Max.
678539	1.5	.48	.56	35	45

KOHLER COIL SPECIFICATIONS

Kohler No.	Engine No.	Mfg.	Mfg. No.	Operating Amperage	Primary Resistance		Secondary Continuity	
					Min.	Max.	Min.	Max.
220080	K91	Scintilla	10-70161	(on stator) 2.1 (off stator) 2.4			40	60
231718	K141, K161, K181	Phelon	FG-6547	1.0			60	75
232901	K241, K301	Phelon	FG-7427	2.1			52	62
234422	K301, K321, K181, K241	Phelon	FG-7969	2.1			52	62
C270590	K662	Wico	X12810 (complete magneto XH2062C using above coil)	1.7			60	75
270775	K662	Fairbanks-Morse	Q2477CX	1.7			50	70
B270966	K662	Wico	X12609 (complete magneto XH2485C using above coil)	1.7			55	70
271144	K662	Wico	X12609	1.7			55	70
**275756	K241	Phelon	FG-1641	2.2			50	70
****33-145-02	K309-1	Robert Bosch	2-204-211-008	1.0	1.5	1.9	40	50
****34-145-02	K295-1, K309-1, K335-1, K399-2, K440-2, K618-2	Robert Bosch	0-221-500-800	.6	1.6	2.0	35	45
****36-145-02	K618-2	Robert Bosch	2-204-211-009	1.0	1.6	2.0	40	50

**Secondary continuity changed from manual page #89.

****To test coil, disconnect the internal battery and connect leads to a 12 volt storage battery. Do not use the 12 volts for any other tests as all other readings will be incorrect.

KOHLER LIGHTING COIL SPECIFICATIONS

Kohler No.	Engine No.	Mfg.	Mfg. No.	Resistance
33-145-04	K295-1, K309-1, K335-1	Robert Bosch	1-214-210-182	3.5
34-145-03	K399-2, K618-2	Robert Bosch	1-214-210-165	1.6 approx.
34-145-04	K399-2, K440-2	Robert Bosch	1-214-210-184	3.0 approx.
34-145-05	K399-2, K440-2	Robert Bosch	1-214-210-183	3.0

KOHLER CONDENSER SPECIFICATIONS

Kohler No.	Engine No.	Mfg.	Mfg. No.	Capacity Reading In Microfarads	
				Min.	Max.
**220062	K141, K91, K161	Scintilla	10-79168Y	.18	.23
**230722	K91, K141, K161, KV161, K181, K241, K301, K482	Delco-Remy	1942948	.27	.31
230980	K141, K161	Scintilla	10-126216	.27	.31
231719	K141, K161, K181	Phelon	FG 6548	.24	.28
232813	K241	Phelon	FG 7437	.13	.16
A235648	K241	Phelon	FG 7251	.12	.14
235786	K181, K241, K301, K321	Phelon	FG 7533	.13	.16
266562	L600	Fairbanks-Morse	AX-M-R2433	.18	.23
280969	K662, L600	Fairbanks-Morse	SXY2433	.28	.33
33-147-01	K295-1, K309-1, K335-1, K399-2, K440-2, K618-2	Robert Bosch	1-237-330-037	.26	.30

**Capacity reading changed from manual page 89.

MALLORY ELECTRIC CORPORATION COIL SPECIFICATIONS

Coil No.	Operating Amperage	Primary Resistance		Secondary Continuity		Ballist Resistance	
		Min.	Max.	Min.	Max.	Min.	Max.
28670	1.0	.5	.55	60	70	.4	.5
28675	.8	.6	.8	60	70	.74	.82

MC CULLOCH CORPORATION COIL SPECIFICATIONS

Coil No.	Saw Model No.	Operating Amperage	Primary Resistance		Secondary Continuity	
			Min.	Max.	Min.	Max.
57643	250, 550, 940	1.7	.5	.6	45	55
**57643A 67921	10 Series, CP 55, CP 70, 795L, 797, CP 125, 660, 895	1.5	.48	.55	45	55
68707	PM-6, PM-6A	1.6	.7	.9	53	63
***69798		1.45	.9	1.5	50	60
		1.5	.7	.8	55	65

**Replace Coil #55949A (C4) Page 104 of Manual of Operation

***Replaces Coil #62927 (E65) Page 104 of Manual of Operation

O & R ENGINE COIL SPECIFICATIONS

Coil No.	Operating Amperage	Primary Resistance		Secondary Continuity	
		Min.	Max.	Min.	Max.
A-149-3	1.5	.65	.8	48	58

O & R ENGINE CONDENSER SPECIFICATIONS

Condenser No.	Capacity Reading In Microfarads	
	Min.	Max.
FG-8095	.24	.28

OMC-EVINRUDE & JOHNSON MAGNETO & BATTERY COIL SPECIFICATIONS

Coil No.	Operating Amperage	Primary Resistance		Secondary Continuity	
		Min.	Max.	Min.	Max.
*580688	1.4	too low to read		22	26
*580730	1.4	too low to read		22	26
*580740	1.4	too low to read		22	26
*580847	1.4	too low to read		22	26

Coil #112-931 is replaced with coil #379-569

580571	Ignition driver coil	.8 ohm
580572	Ignition driver coil	.8 ohm

*To check coil, use C. D. Adaptor, part #55-980.

ONAN ENGINE/GENERATOR DIVISION OF STUDEBAKER CORP.
COIL SPECIFICATIONS

Model No.	Coil Number	Operating Amperage	Primary Resistance		Secondary Continuity	
			Min.	Max.	Min.	Max.
CCKA	160C792 to Spec G	.75	.7	.8	50	60
	166C346 begin Spec G	.9	.87	1.0	60	70
CCKB	166C346	.9	.87	1.0	60	70

CONDENSER SPECIFICATIONS

Condenser No.	Condenser Microfarads	
	Min.	Max.
312A69	.28	.32

PRESTOLITE COIL SPECIFICATIONS

Coil No.	Operating Amperage	Primary Resistance		Secondary Continuity	
		Min.	Max.	Min.	Max.
*1DD-1010	1.3	.12	.16	8	10
****201694	.8	3.4	4.2	57	67
201729	3.6	.25	.31	37	47

*To test coil, use C. D. Adaptor, part #55-980.

****To test coil, disconnect the internal battery and connect leads to a 12 volt storage battery. Do not use the 12 volts for any other tests as all other readings will be incorrect.

R. E. PHELON COIL SPECIFICATIONS

Coil No.	Operating Amperage	Secondary Continuity	
		Min.	Max.
FG 1484	2.2	50	70
FG 2731	2.8	40	60
FG 3003	2.8	50	70
FG 3426	1.0	55	75
FG 4213	2.5	45	65
FG 4400	2.5	47	57
FG 5773	2.5	52	62
FG 6109	2.8	45	60
FG 6110	2.8	45	60
FG 6199	2.8	50	70
FG 6201	2.8	50	70
FG 6223	2.8	50	70
FG 6358-B	2.8	45	60
FG 6358-C	2.8	45	60
FG 6503	2.8	45	60
FG 6850	2.8	45	60
FG 6852	2.8	45	60
FG 7106	2.8	45	60
FG 7149	2.8	50	70
FG 7202-B	1.6	45	55
FG 7211	1.8	50	60
FG 7513	2.7	50	65
FG 7601	2.25	60	70
**FG 7670	2.5	60	70
FG 7795	2.1	51	61
**FG 7898	1.7	75	85
FG 7969	2.1	52	62
FG 8054	2.8	50	70
FG 8054-1	2.8	50	70
FG 8119	2.2	54	65
FG 8133	2.2	54	65
FG 8515	2.7	50	65
FG 8619	2.25	60	70
FG 8635	2.6	58	69

**Ground out one secondary terminal while testing other.

R. E. PHELON CONDENSER SPECIFICATIONS

Condenser No.	Capacity Reading In Microfarads	
	Min.	Max.
FG 607-C	.15	.19
FG 7022	.15	.19
FG 7022-B	.15	.19
FG 7047	.18	.22
FG 7146	.18	.22
FG 7157	.15	.19
FG 7184	.24	.28
FG 7224	.15	.19
FG 7239	.18	.22
FG 7437	.12	.17
FG 7437-B	.12	.17
FG 7507	.15	.19
FG 7533-B	.12	.17
FG 7829	.26	.32
FG 7909	.11	.15
FG 8052	.15	.19
FG 8095	.24	.28
FG 8244	.15	.19
FG 8466-S	.17	.23
FG 8589	.15	.19

ROBERT BOSCH COIL SPECIFICATIONS

Coil No.	Operating Amperage	Primary Resistance		Secondary Continuity	
		Min.	Max.	Min.	Max.
2-204-211-007	1.3	.5	1.1	42	52
****2-204-211-009	1.0	1.6	2.2	40	50

Lighting Coil No.	Resistance
1-214-210-030	.2
1-214-210-076	2.4
1-214-210-077	1.1
1-214-210-105	1.2
1-214-210-106	.55 approx.
1-214-210-107	3.5
1-214-210-159	1.7
1-214-210-160	1.35
1-214-210-161	.1
1-214-210-162	1.25
1-214-210-164	1.18
1-214-210-165	1.6 approx.
1-214-210-182	3.5
1-214-210-183	3.0
1-214-210-184	3.0 approx.
1-214-210-188	1.6

****When testing above coils, disconnect the 7-1/2 volt internal battery and connect leads to a 12 volt storage battery for coil power test only.

SKI-DOO
(See Bombardier)

TECUMSEH (LAUSON POWER PRODUCTS) COIL SPECIFICATIONS

Coil No.	Operating Amperage	Primary Resistance		Secondary Continuity	
		Min.	Max.	Min.	Max.
610633	1.7	.5	.6	40	50
**610657	1.4	.85	.95	50	60
*610760	1.5	.9	1.3	25	35
610765	1.7	.45	.55	50	60
610768	1.6	.45	.55	48	58
*610783	1.45	.3	.4	23	33
*610785	1.55	too low to read		55	65
*610792	1.55	too low to read		55	65

*To check these coils, use C. D. Adaptor #55-980.

**Correction to Operational Manual, Page 90.

TECUMSEH (LAUSON POWER PRODUCTS) CONDENSER SPECIFICATIONS

Condenser No.	Capacity Reading In Microfarads	
	Min.	Max.
610642	.16	.18
610732	.16	.18
610767	.16	.18
For Magneto Stator	Resistance	
	Min.	Max.
610761	.25	.34 (alternator coil assy.)
610764	.3 approx.	
610784	.25	.34
Lighting Coil Stator Windings	.2	.28

WICO MAGNETO COIL SPECIFICATIONS

Coil No.	Operating Amperage	Secondary Continuity	
		Min.	Max.
X12609	1.7	55	70
X12810	1.7	60	75
X12905B	1.7	55	65
X12910B	1.7	55	65
X12915B	1.7	55	65
X12920B	1.7	55	65
X12935	1.7	55	65
X12935B	1.7	55	65
X12940	1.5	50	60
X12940B	1.7	55	65
X13000B	2.0	50	60
X13313D	1.7	55	65
X13655B	1.7	55	65
X14171E	1.3	55	65
X14276D	1.4	55	65
X14381C	1.4	55	65
X14877C	1.7	55	65
X16330	1.3	55	65
X16343D	1.3	55	65
X16381D	1.8	55	65
X16398C	1.7	55	65
X16825C	1.7	55	65
X16893C	1.7	55	65
X17566B	1.3	55	65
X17605B	1.7	55	65
X30081B	1.1	40	50

WICO CONDENSER SPECIFICATIONS

Condenser No.	Capacity Reading In Microfarads	
	Min.	Max.
X16781	.16	.20
X16835	.16	.20
X16888	.16	.20
X17767	.16	.20



**1971-72-73
SUPPLEMENTARY
BULLETIN**

**For
Model 98 and 98A
IGNITION
ANALYZER MANUAL**

PIONEER C.D. IGNITION SYSTEM
Wico Prestalite #FW 2906
As used on Pioneer Chain Saw Model #3071

Ignition Coil Testing #X 18122

To Test This Coil C.D. Adaptor #55-980 must be used.

Operating Amperage	Primary Resistance	Secondary Continuity
1.7	.29 - .34	12 - 18

Condenser Testing (Refer to page 11, 12 & 13 for testing Procedures)
Condenser #X 18092 - .65 to .75 MFD.

Charging Coil Testing #X 18111 (Electronics Group)

1. Turn selector switch to position #3 Coil Continuity.
2. Clip small red and black test leads together.
3. Turn meter adjustment knob for scale #3 until meter pointer lines up on set position on right side of scale #3.
4. Unclip test leads.
Charging coil has three leads, one red with quick connector, one black with quick connector, and one black with female plug quick connector.
5. Attach black test lead of analyzer to black lead with female plug quick connector. (Be sure alligator clip makes contact in plug quick connector.) For the next three tests this connection will remain the same.
6. Attach red test lead from analyzer to red lead with quick connector.
7. Meter scale #3, in red figures should read approximately 600 ohms + - 5%.
8. Leave black test lead attached to black lead with plug quick connector.
9. Remove red test lead from coil red lead and attach to coil lamination.
10. Meter scale #3, should read approximately 720 ohms + - 5%.
11. Remove red test lead from coil laminations and attach to coil black lead with quick connector.
12. Meter scale #3, should read approximately 600 ohms + - 5%.
13. Remove red and black test lead from charging coil.
14. Attach red test lead to black lead with female plug quick connector. (Be sure alligator clip makes good contact in plug quick connector.)
15. Attach black test lead to lamination, red lead and the other black lead.
16. There should be no meter reading. Should you obtain any reading the pulse pack is defective.
17. Remove red and black test leads from charging coil.
18. Attach red test lead to black lead with quick connector.
19. Attach black test lead to lamination.
20. Meter scale #3 should read approximately 200 ohms.
21. Reverse steps 18 and 19, (red and black test leads). Meter reading should be the same as in step 20.

22. Leave black test lead attached to black lead with quick connector.
23. Remove red test lead from lamination and attach to red lead with quick connector.
24. There should be no meter reading.
25. Reverse steps 22 and 23 (red and black test leads). Again there should be no meter reading.
26. Leave black test lead attached to red lead of coil.
27. Remove red test lead from black lead and attach it to lamination.
28. There should be no meter reading.
29. Reverse steps 26 and 27 (red and black test leads). Again there should be no meter reading.
30. You have completed testing the charging coil.

**ARCTIC CAT COIL SPECIFICATIONS
KAWASAKI ENGINE**

Coil No.	Operating Amperage	Primary Resistance		Secondary Continuity	
		Min.	Max.	Min.	Max.
3000-062	.8	.8	1.1	35	50
3000-196	.9	.7	.9	45	55
3000-201	.9	.7	.9	45	55
3000-275	.9	.7	.9	45	55
3000-276	1.8	.3	.45	see note	
3000-277	.9	.7	.9	45	55

NOTE: There is no continuity between primary and secondary leads, however, continuity between secondary leads is 50 - 70. See page 23, Figure 26 in manual for test procedure.

ARCTIC CAT CONDENSER SPECIFICATIONS

Condenser No.	Capacity Reading in Microfarads		
	Min.	Max.	
3000-076	.17	.22	
3000-186	.23	.27	
Exciting Coil	OHMS		
	Min.	Max.	
3000-178	1.4	2.0	
3000-290	200	300	
Lighting Coil			
	3000-063	.35	.45
	3000-179	.7	.9
3000-292	.7	.9	

AMERICAN BOSCH COIL SPECIFICATIONS

Coil No.	Operating Amperage	Primary Resistance		Secondary Continuity	
		Min.	Max.	Min.	Max.
TCG 90 A 3S	1.9	.45	.65	47	57
TCG 90 A 4S	1.9	.4	.6	48	58
TCG 90 B 4S	2.3	.15	.35	56	66
*TCJ 3A 1	1.8	2.5	3.5	58	69

*To test this coil, use C.D. Adaptor Part #55-980.

ROBERT BOSCH COIL SPECIFICATIONS

Coil No.	Operating Amperage	Primary Resistance		Secondary Continuity	
		Min.	Max.	Min.	Max.
*0-212-940-002	1.6	1.6	2.0	50	60

Lighting Coil No.

Resistance

1-214-210-120	.12 approx. (not grounded)
1-214-210-195	2.3 approx. (not grounded)
1-214-210-370	1.3

*To test coil, disconnect the 7½ volt internal battery and connect leads to a 12 volt battery for COIL POWER TEST ONLY.

BRIGGS & STRATTON COIL SPECIFICATIONS

Supersedes Page 56 of Operational Manual

Coil No.	Engine Models	Operating Amperage	Primary Resistance		Secondary Continuity	
			Min.	Max.	Min.	Max.
29656	A-B-ZZ	.5	.6	.8	40	50
29657	A-B-ZZ	.5	.6	.8	40	50
290880	9-14-19-23-191400-231400	1.15	—	—	36	36
**291617	6-6B-60000-80000	1.7	.3	.5	35	45
291617A		1.7	.25	.35	45	55
292184	6-6B	1.7	.3	.5	35	45
293289	A-B-ZZ	.5	.6	.8	40	50
*293431	9-14-19-23	1.2	.5	.7	50	60
294319	6B	1.7	.3	.5	35	45
295680	6B-60000-80000	1.7	.3	.5	35	45
295845	140000-141000-142000-143000	1.7	.3	.5	35	45
*295915	6B-60000	2.0	.2	.35	40	50
296084	6B	1.7	.3	.5	35	45
296171	{ 80600-81600-80800-81800 } { 84500-85500-84900-85900 }	1.7	.3	.5	35	45
296703	140000-141000-142000-143000	1.7	.3	.5	35	45
296834	140000-141000-142000-143000	1.7	.3	.5	35	45
296858	60000-80000	1.7	.3	.5	35	45
297307	60000-80000 (Use 298502)	1.6	.2	.3	25	35
297320	140000-141000-142000-143000	1.7	.3	.5	35	45
298274	60000-80000	1.6	.2	.3	25	35
298316	100200-100900	1.8	.18	.24	25	35

BRIGGS & STRATTON COIL SPECIFICATIONS (Cont'd.)

Coil No.	Engine Models	Operating Amperage	Primary Resistance		Secondary Continuity							
			Min.	Max.	Min.	Max.						
298443	60000-80000	1.8	.18	.24	25	35						
298502	60000-80000	1.6	.2	.3	25	35						
298524	100200-100900	1.6	.2	.3	25	35						
298654	60000-80000	1.6	.2	.3	25	35						
298968	144000-145000-146000-147000 170000-171000-190000-191700 193000-233000-243000-200400 243400-300400-301400-320400 325400	1.6	.18	.24	40	50						
299366							146400	1.5	.22	.28	37	47
299700							200400	1.6	.18	.24	40	50

*NOTE: There is no continuity between primary and secondary leads, however, continuity between secondary leads is as listed in chart. See page 23, Figure 26 in manual for test procedure.

BRIGGS & STRATTON CONDENSER SPECIFICATIONS

Condenser No.	Capacity Reading In Microfarads	
	Min.	Max.
29861	.16	.26
291369	.16	.26
294628	.16	.26

CANADIAN CURTISS WRIGHT COIL SPECIFICATIONS

KOKUSAN ENGINE #399CC

Coil No.	Operating Amperage	Primary Resistance		Secondary Continuity	
		Min.	Max.	Min.	Max.
18-0006-50	.5	1.2	1.8	50	70
18-0008-00	.5	1.2	1.8	50	70

CANADIAN CURTISS WRIGHT CONDENSER SPECIFICATIONS

Condenser No.	Capacity Reading in Microfarads	
	Min.	Max.
18-0004-90	.225	.275
18-0007-40	.225	.275

CANADIAN CURTISS WRIGHT SPECIFICATIONS (Cont'd.)

<u>Stator-Ignition Winding</u>	<u>OHMS</u>	
	<u>Min.</u>	<u>Max.</u>
18-0004-60	.9	1.4
18-0007-20	.9	1.4
Lighting Coil		
18-0004-70	.4	.6
Heat Sink Check		
Red lead to heat sink plate		
Black lead to fuse terminal	8	15
Red lead to fuse terminal		
Black lead to heat sink terminal	no continuity	
Stator Check		
Red lead to blue wire		
Black lead to ground	.4	.6

DELCO-REMY COIL SPECIFICATIONS

<u>Coil No.</u>	<u>Operating Amperage</u>	<u>Primary Resistance</u>		<u>Secondary Continuity</u>	
		<u>Min.</u>	<u>Max.</u>	<u>Min.</u>	<u>Max.</u>
1115070	.55	3.0	4.0	39	49
1115222	.55	3.0	4.0	39	49

HIRTH COIL AND CONDENSER SPECIFICATIONS

Ignition Coil

Hirth Coil No. 020.13/3 refer to Robert Bosch No. 0-212-940-001

General Armature

Hirth Coil No. 021.5/4 refer to Robert Bosch No. 1-214-210-160
 Hirth Coil No. 021.18/4 refer to Robert Bosch No. 1-214-210-159

Condenser

Condenser No. 021.17/7 refer to Robert Bosch No. 1-237-330-037

AMERICAN HONDA COIL & CONDENSER SPECIFICATIONS

Coil No.	Operating Amperage	Primary Resistance		Secondary Continuity		Condenser Capacity Reading In Microfarads	
		Min.	Max.	Min.	Max.	Min.	Max.
*30400-028-014	1.2	1.0	1.6	55	65		
*30400-045-020	1.1	1.4	2.0	60	75		
*30400-074-000	1.4	1.4	1.8	55	65		
*30400-089-672	1.3	1.4	2.0	70	80	.22	.28
30400-107-007	1.2	1.0	1.6	55	70		
30400-114-017	1.3	.8	1.2	40	50	.24	.26
*30400-118-017	1.4	.8	1.2	60	75	.22	.28
30400-303-004	1.0	1.0	1.6	60	75		
*30500-035-004	.7	3.0	5.0	50	65		
*30500-063-004	1.3	2.0	3.0	45	60		
*30500-098-671	1.1	1.6	2.5	55	65		
30500-230-000	1.0	1.0	1.4	60	70		
*30500-300-013	.8	3.0	5.0	(see note)			
*30500-310-670	.9	3.0	5.0	55	65	.22	.28
*30500-918-670	1.1	2.0	3.0	50	65	.22	.28

Lighting & Exciter Coil

30540-044-004
30540-045-670
30540-114-004
311-918-004

Resistance

1.4 ohms approx.
1.2 ohms approx.
1.3 ohms approx.
3.5 ohms approx. (coil is grounded)

*DISCONNECT internal battery and connect leads from analyzer to a 12 volt storage battery or equal. This test is for COIL POWER TEST ONLY. When using the Model 98, do not use the 12 volts for any other tests as readings will be incorrect.

NOTE: There is no continuity between primary and secondary leads, however, continuity between secondary leads is 65 - 75. See page 23, Figure 26 in manual for test procedure.

JONSEREDS CHAIN SAWS

TILTON EQUIPMENT COMPANY COIL & CONDENSER SPECIFICATIONS

Coil No.	Model No.	Operating Amperage	Primary Resistance		Secondary Continuity	
			Min.	Max.	Min.	Max.
3917	50, 601, 751, 621, 80	.65	48	58	1.0	1.4

Generator Coil No.	Model No.	Resistance	
		Min.	Max.
3923	601, 751, 621, 80	.8	1.0
391301	50	.6	.8

Condenser No.	Model No.	Capacity Reading In Microfarads	
		Min.	Max.
391901	50	.18	.22
392200	601, 751, 621, 80	.26	.30

MOTO-SKI COIL & CONDENSER SPECIFICATIONS

BSE ENGINE

Coil No.	Engine	Operating Amperage	Primary Resistance		Secondary Continuity	
			Min.	Max.	Min.	Max.
*801065	1972 - 440CC	1.8	1.4	1.8	40	50
801087	1972 - 340CC	1.5	.3	.4	50	60
801101	1972 - 250CC	1.5	.3	.4	50	60
*801125	1973 - 250CC, 340CC, 440CC	1.8	1.4	1.8	40	50

Magneto No.	Engine	Condenser Capacity Reading in Microfarads		Excitor Coil		Alternator Coil
		Min.	Max.	Min.	Max.	
801075	1972 - 440CC	.16	.20	1.0	1.2	.75 - .8 approx. (grounded)
801081	1972 - 340CC	.25	.29	1.0	1.2	.8 approx. (grounded)
801102	1972 - 250CC	.25	.29	1.0	1.4	.75 - .8 approx. (grounded)
801145	1973 - 250CC	.16	.20	1.4 ohm approx.		.75 - .80 approx. (not grounded)
801159	1973 - 340CC, 440CC	.16	.20	1.4 ohm approx.		.75 - .80 approx. (not grounded)

*Disconnect internal battery and connect leads from analyzer to a 12 volt storage battery or equal. This test is for COIL POWER TEST ONLY. DO NOT USE THE 12 VOLTS FOR ANY OTHER TESTS AS READING WILL BE INCORRECT.

KOHLER COMPANY COIL & CONDENSER SPECIFICATIONS

Kohler No.	Engine No.	Mfg.	Mfg. No.	Operating Amperage	Primary Resistance		Secondary Continuity	
					Min.	Max.	Min.	Max.
231281	{ K 91, K141, K161, K181, K241, K 301 K321, K331 KV181 K482 K141, K161, K181	Delco-Remy	1115070	.55	3.0	4.0	39	49
232897		Phelon	FG7423-1	2.1			52	62
277449		Phelon	FG7898	1.7			75	85
41-145-01		Phelon	FG7969-1-B	2.1			52	62

KOHLER LIGHTING COIL SPECIFICATIONS

Kohler No.	Engine No.	Mfg.	Mfg. No.	Resistance
33-145-01	K295-1, K309-1, K335-1	Robert Bosch	1-214-210-160	1.35 approx.
34-145-01	K399-2, K440-2, K618-2	Robert Bosch	1-214-210-163	1.0 approx.
34-145-06	K295-2, K340-2, K399-2, K440-2AX	Robert Bosch	1-214-210-159	1.0 approx.

KOHLER CONDENSER SPECIFICATIONS

Kohler No.	Engine No.	Mfg.	Mfg. No.	Capacity Reading In Microfarads	
				Min.	Max.
234573	KV181	Phelon	FG7130-B	.15	.19
271878	K662	Mallory	#400	.27	.29

MC CULLOCH CORPORATION COIL SPECIFICATIONS

Coil No.	Saw Model No.	Operating Amperage	Primary Resistance		Secondary Continuity	
			Min.	Max.	Min.	Max.
57643A	{ Mac 35, 200, 300, 1-40, 400, 1-50, 550, 600, Mac 15. 900 Series }	1.5	.45	.70	46	54
58822	940	1.5	.45	.70	46	54
84957	PM6, MM6	1.5	.70	1.20	50	60
84972	{ Mac 10 series, CP-SP 55-70 and 80, 795, 895, CP125 }	1.5	.60	.90	50	70
85243	SP-125	1.5	.60	.90	50	70

MERCURY MARINE COIL SPECIFICATIONS

Coil No.	Operating Amperage	Primary Resistance		Secondary Continuity	
		Min.	Max.	Min.	Max.
59300	.5	1.2	1.8	50	70
59301	.5	1.2	1.8	50	70

MERCURY MARINE CONDENSER SPECIFICATIONS

Condenser No.	Capacity Reading In Microfarads	
	Min.	Max.
59282	.225	.275
59284	.225	.275
Stator-Ignition Winding	Resistance	
	Min.	Max.
59298	.9	1.4
59324	.9	1.4
Lighting Coil		
59299A1	.4	.6
Heat Sink Check		
Red lead to heat sink plate	8	15
Black lead to fuse terminal		
Red lead to fuse terminal	no continuity	
Black lead to heat sink plate		
Stator Check		
Red lead to blue wire	.4	.6
Black lead to ground		

O & R ENGINES, INC. COIL & CONDENSER SPECIFICATIONS

Coil No.	Operating Amperage	Primary Resistance		Secondary Continuity	
		Min.	Max.	Min.	Max.
400010	1.5	.9	1.5	42	52
		Capacity Reading In Microfarads			
		Condenser No.		Min.	Max.
		400293		.16	.20

OMC — EVINRUDE & JOHNSON COIL & CONDENSER SPECIFICATIONS

Coil No.	Operating Amperage	Primary Resistance		Secondary Continuity	
		Min.	Max.	Min.	Max.
383444	1.0	1.2	1.6	50	60
*580821 (See Note)	1.4	too low to read		20	30
*580944	1.7	too low to read		20	30
580971	1.6	.5	.7	35	45
*580976	1.7	too low to read		20	30
*580977	1.7	too low to read		20	30
*580981	1.7	too low to read		20	30
581124	1.0	.45	.60	45	55
*581024	1.7	too low to read		20	30
*581032 (See Note)	1.4	too low to read		20	30
*581038	1.7	too low to read		20	30
Ignition driver coil					
580749		.8 ohms approx.			

NOTE: Magneto CD Coils — Connect black lead of tester to orange lead of ignition coil.
Connect red lead of tester to orange black stripe lead of coil.

NOTE: Coil 112931 is replaced with 383444.

*To check coil, use CD Adaptor, part #55-980.

Condenser No.	Capacity Reading In Microfarads	
	Min.	Max.
380537	.18	.23
382125	.18	.23
382136	.27	.29

ONAN ENGINE/GENERATOR DIVISION OF STUDEBAKER CORP.

COIL SPECIFICATIONS

Coil No.	Operating Amperage	Primary Resistance		Secondary Continuity	
		Min.	Max.	Min.	Max.
*166B535	1.9	3.5	4.5	(see note)	(see note)

*To test coil, use C.D. Adaptor, Part #55-980.

NOTE: There is no continuity between primary and secondary leads, however, continuity between secondary leads is 65 - 75. See page 23, Figure 26 in manual for test procedures.

R. E. PHELON COMPANY COIL AND CONDENSER SPECIFICATIONS

Coil No.	Operating Amperage	Secondary Continuity	
		Min.	Max.
FG 6240	2.7	55	65
FG 6240-H	2.7	55	65
FG 7423-1	2.1	52	62

**ROCKWELL MANUFACTURING COMPANY
JLO ENGINE DIVISION
COIL & CONDENSER SPECIFICATIONS**

Ignition Coil — For use on JLO Engine L227, L230, L295, L297, L300, L372, L380, L395, L340, LR 340T2, L399/2, LR 454/2, LR 744/2, LR760/2, LB 600/2, R440/2

JLO Coil No.	Mfg.	Mfg. No.	Operating Amperage	Primary Resistance		Secondary Continuity	
				Min.	Max.	Min.	Max.
*000.43.05.606	Bosch	0-212-940-001	.6	1.6	2.0	50	60

Generator Armature — For use on JLO Engine L295, L297, L300, L392, L380, L395, LB600/2

Mfg.	Mfg. No.	Resistance
Bosch	1-214-210-160	1.35
For use on JLO Engine L340, LR340T2, L399/2, LR454/2, LR744/2, LR760/2		
Bosch	1-214-210-159	1.0

Condenser — For use on JLO Engine L227, L230, L295

JLO No.	Mfg.	Mfg. No.	Capacity Reading In Microfarads	
			Min.	Max.
000.43.06.520	Bosch	1-237-330-035	.13	.17

For use on Engine L297, L300, L372, L380, L395, L340, LR340T2, L399/2, LR454/2, LR744/2, LR760/2, LB600/2.

000.43.065.30	Bosch	1-237-330-037	.26	.30
---------------	-------	---------------	-----	-----

*When testing above coil, disconnect the 7½ volt internal battery and connect leads to a 12 volt storage battery for coil power test only.

RUPP INDUSTRIES COIL & CONDENSER SPECIFICATIONS

(TOHATSU ENGINE NO. 4155AC01)

Coil No.	Operating Amperage	Primary Resistance		Secondary Continuity		Capacity Reading In Microfarads	
		Min.	Max.	Min.	Max.	Min.	Max.
*17055	1.5	1.0	1.4	45	55		
*17056	1.5	1.0	1.4	45	55		
Condenser No.							
17046						.16	.20
Magneto Booster Coil #1 and #2.							
		Min.	Max.				
17047 & 17120		1.0	1.2				

*To check coil use C.D. Adaptor #55-980

SACHS COIL & CONDENSER SPECIFICATIONS

Ignition Coil — For use on Sachs Engine SA2-290, SA2-340, SA2-440, SA2-740C

Sachs' Coil No. 0-283-109-000 refer to Robert Bosch No. 0-212-940-001
Sachs' Condenser No. 0-965-091-000 refer to Robert Bosch No. 1-237-330-037

SKIROULE, LTD. COIL & CONDENSER SPECIFICATIONS

Skiroule Coil No. 6070-4007 refer to Robert Bosch No. 0-212-940-001
Skiroule Condenser No. 6068-4022 refer to Robert Bosch No. 1-237-330-037

STIHL PARTS, INC., COIL AND CONDENSER SPECIFICATIONS

Coil No.	Operating Amperage	Primary Resistance		Secondary Continuity	
		Min.	Max.	Min.	Max.
1111-404-3200	1.2	.7	.9	48	58
1113-400-1300	1.7	.7	.9	48	58
1114-404-3200	1.4	1.2	1.6	53	68

Condenser No.	Capacity Reading In Microfarads	
	Min.	Max.
1113-404-3400	.18	.22
1114-404-3400	.18	.22

TECUMSEH (LAUSON POWER PRODUCTS) COIL SPECIFICATIONS

Coil No.	Operating Amperage	Primary Resistance		Secondary Continuity	
		Min.	Max.	Min.	Max.
**30560	1.6	.45	.55	50	60
32080	.55	3.0	4.0	39	49

**Correction to operational manual, page 90, for units sold prior to fall of 1971.

TRIUMPH MOTORCYCLE CORPORATION COIL AND CONDENSER SPECIFICATIONS

Coil No.	Mfg.	Operating Amperage	Primary Resistance		Secondary Continuity	
			Min.	Max.	Min.	Max.
*45223	Lucas	2.0	3.2	3.8	40	50

Condenser No.	Capacity Reading In Microfarads	
	Min.	Max.
54420128	.21	.27

Lighting No.	Resistance	
	Min.	Max.
**47204		
Green/White Green/Black		1.2
Green/White Green/Yellow		.6
Green/Yellow Green/Black		1.9

*To test this coil, use C. D. Adaptor #55-980.

**Resistance between the leads is an approximate reading. Allow +- 10%. No lead should be grounded.

**YAMAHA INTERNATIONAL CORP. COIL SPECIFICATIONS
SNOWMOBILE**

Coil No.	Model No.	Operating Amperage	Primary Resistance		Secondary Continuity	
			Min.	Max.	Min.	Max.
*806-82310-40	SL338B, GP396, SS433	1.9	1.5	2.1	70	80
810-82310-40	SW396	.9	.6	1.0	45	55
810-82320-41	SW396	1.0	.6	1.0	45	55
812-82310-40	SL292	1.0	.6	1.0	45	55

Source Coil No.		Resistance	
806-81312-20	SL338B	1.3	*(two windings with one side to ground — test from ground to winding — tested together 3.0 reading)
810-81312-20	SW396, GP396	1.8	
812-81312-20	SL292, SS433	1.8	
*820-81312-50	SR433	1.5	

Lighting Coil		Resistance	Color of Lead
**806-81313-20	SL338B	.4 approx. .3 approx. .2 approx.	Copper Red Yellow
**810-81313-20	SW396, GP396, SS433	.15 approx. .65 approx. .4 approx. .275 approx.	Black Copper Red Yellow
**812-81313-20	SL292	.125 approx. .7 approx. .4 approx. .3 approx.	Black Copper Red Yellow
***820-81313-50	SR433	.15 approx. .75—.85 ohms	Black

*To check this coil, use C.D. Adaptor #55-980.

**Attach one test lead to ground or lamination.

***This coil has 4 leads which are in series. The Yellow and Black leads have 2 wires — These wires must be connected to test coil. Attach one test lead to ground for lamination, the other to Red lead.

YAMAHA INTERNATIONAL CORP. CONDENSER SPECIFICATIONS

Snowmobile Condenser No.	Model No.	Capacity Reading In Microfarads
802-81325-20	SL 338B, SW 396, GP 396, SL292	.25
802-81325-50	SR433, SW433	.25

**YAMAHA INTERNATIONAL CORP. COIL SPECIFICATIONS
MOTORCYCLE**

Coil No.	Model No.	Operating Amperage	Primary Resistance		Secondary Continuity	
			Min.	Max.	Min.	Max.
**168-82310-70	CS3B	1.7	4.0	5.0	53	63
206-82310-40	G6SB	1.1	.5	.8	40	50
214-82310-40	DT1, DT1MX, RT1, RT1MX	1.3	.5	.75	40	50
**227-82310-60	AT1	1.9	3.5	4.5	55	65
*248-82310-10	HT1, AT1MX, CT1, JT1	.8	4.7	5.3	55	65

Source Coil	Resistance
185-81312-10 HT1	2.4 approx.
207-81312-20 G6SB	1.2 approx.
214-81312-21 DT1, DT1MX	1.35 approx.

Lighting Coil	Resistance	Color Of Lead
***232-81313-20 G6SB	.55 approx. .35 approx. .2 approx. .05 approx.	Green/Red Yellow w/quick conn. Green Yellow short wire
**233-81313-20 RT1, DT1 RT1MX DT1MX	.15 approx. .075 approx. .05 approx.	Copper Red Black
**233-81314-20 RT1, DT1 RT1MX DT1MX	.15 approx. .05 approx. .075 approx.	Copper Black Red
***251-81313-10 CT1	.75 approx. .15 approx. .15 approx.	Green/Red Green Yellow
***277-81313-10 HT1	.8 approx. .2 approx. .45 approx.	Green/Red Green Yellow

*Disconnect internal battery and connect lead from analyzer to a 12 volt storage battery or equal. This test is for Coil Power Test Only. Do not use the 12 volts for any other tests as readings will be incorrect.

**To test, use CD Adapter, part #55-980.

***Attach one test lead to ground or lamination

YAMAHA INTERNATIONAL CORP. CONDENSER SPECIFICATIONS

Motorcycle	Condenser No.	Model No.	Capacity Reading In Microfarads
	104-81326-20	G6SB	.22
	132-81225-10	CS3B	.22
	148-81126-10	CT1, AT1	.22
	183-81425-10	HS1B	.22
	207-81326-10	JT1, HT 1	.25
	207-81313-10	AT1MX	.25
	214-81326-20	DT1, DT1MX, RT1, RT1MX	.25
	256-81620-10	XS1	.22
	278-81625-00	R5	.22



1974-1975
SUPPLEMENTARY
BULLETIN

For
Model 73, 98 and 98A
IGNITION
ANALYZER MANUAL

PREFIX

MFG.	PG. NO.
American Bosch	3
Arctic Cat	3
Chrysler Outboard Corp.	4
Delco-Remy	4
Echo Chain Saw	6-7
Homelite	4-5
Husqvarna	5
Indian Motorcycle	5-6
Jonsereds Chain Saw-Tilton Equipment	6
Kioritz Corp. of America	6-7
Kioritz Engine (Formally CCW)	6
Kohler	8
Mallory	8
OMC-Evinrude & Johnson	8
Onan	9
Phelon	9
Polaris	9
Prestolite (Wico)	10
Robin	10
Sears Craftsman Chain Saw	6-7
Stihl American Inc.	11
Tecumseh Products Co.	11
Tilton	12

**AMERICAN BOSCH
IGNITION COIL SPECIFICATIONS**

Coil No.	Operating Amperage	Primary Resistance		Secondary Continuity	
		Min.	Max.	Min.	Max.
CL521043A	1.3	.5	.7	40	50
TCD 90A4	1.8	.15	.25	30	45
TCD 90B4	1.8	.15	.25	30	45

**ARCTIC CAT
KAWASAKI ENGINE IGNITION COIL SPECIFICATIONS**

Coil No.	Kawasaki Coil No.	Operating Amperage	Primary Resistance		Secondary Continuity	
			Min.	Max.	Min.	Max.
C*3000 - 062	318505-8123-00	1.0	.8	1.2	35	50
B*3000 - 276	318861-8460-00	1.9	.3	.5	55	65
3000 - 441	318801-8460-03	.9	.7	.9	45	55
3000 - 443	318801-8462-03	.9	.7	.9	45	55
3000 - 540	312651-8123-00	1.5	.6	.8	45	55
3000 - 912	318506-8460-00	.7	.7	.9	50	60
A 3000 - 951	318805-8460-00	1.8	1.3	1.7	40	50
A 3000 - 952	318805-8462-00	1.8	1.3	1.7	40	50
B 3001 - 067	318863-8460-00	1.9	.3	.5	55	65
B 3001 - 136	319881-8431-00	2.0	.3	.5	55	65
B 3001 - 137	319331-8432-00	2.0	.3	.5	55	65
D 3001 - 350	318811-8460-00	3.0	.1	or less	8	15
A 3001 - 447	318821-8460-00	1.8	1.3	1.7	40	50
A 3001 - 448	318821-8462-00	1.8	1.3	1.7	40	50
B 3001 - 461	318822-8462-00	1.9	.3	.5	55	65

- A. When testing this coil use C.D. Adaptor #55-980.
- B. See page 23, figure 26 in manual for test procedure.
- C. Model 98, use a 12 volt storage battery or equal for coil power test only. Disconnect internal battery and connect analyzer battery leads to a 12 volt storage battery or equal. Do not use 12 volts for any other tests as reading will be incorrect. Connect to 12 volt storage battery or equal, place selector switch in the 12 V Position.
- D. This coil must be connected as follows for coil power test.
- Step 1. Use C. D Adaptor #55-980
- Step 2. Use a 12 volt battery as in foot note (C)
- Step 3. Coil polarity must be observed to obtain the proper test. Stretch out the two secondary leads to see which is longer. The longer one must be connected to the single red test lead from the analyzer. The other secondary lead is connected to the small black test lead.

In general the negative primary winding is usually a brown wire.

These specifications supersede all previous specifications of these coils.

*Correction to 1971-73 Bulletin page 3.

**CHRYSLER OUTBOARD CORP.
IGNITION COIL SPECIFICATIONS**

Coil No.	Operating Amperage	Primary Resistance		Secondary Continuity	
		Min.	Max.	Min.	Max.
A*12345	1.4	.48	.54	50	60
12348	1.5	.50	.65	50	60
*474475	1.7	Too low to read		7	11
*510475	1.7	.03	.05	230	260

* When testing this coil use C.D. Adaptor #55-980

CONDENSER SPECIFICATIONS

Condenser No.	Capacity Reading In Microfarads	
	Min.	Max.
12042-1	.28	.33
12139-1	.26	.30
12181-2	.16	.20
14022-1	.36	.44

**DELCO-REMY
IGNITION COIL SPECIFICATIONS**

Coil No.	Operating Amperage	Primary Resistance		Secondary Continuity	
		Min.	Max.	Min.	Max.
**166B 535	.9	3	5	65	75
*166 278	1.5	2.5	3.75	60	70

* When testing this coil use C.D. Adaptor #55-980

** Model 98, use 12 volt storage battery or equal for coil power test only. Disconnect internal battery and connect analyzer battery leads to a 12 volt storage battery or equal. Do not use 12 volts for any other tests as reading will be incorrect. Connect to the 12 volt storage battery or equal and place selector switch in the 12 V position.

**HOMELITE
IGNITION COIL SPECIFICATIONS**

Homelite Number	Vendor Name	Vendor Number	Operating Amperage	Primary Resistance		Secondary Continuity	
				Min.	Max.	Min.	Max.
32090	Wico	X-7233	1.80			40	60
54421	Wico	X-16809C	1.3			50	60
54747A	Wico	X-17605-B	1.7			40	50
55986A	Phelon	FG-3082-B	2.8			50	70
63998A	Wico	X16835	1.5	.7	.9	45	60
64091	Wico	X16825-D	1.3			50	60
67516	Wico	X17566-B	1.3			55	65
68149	Wico	X18015	1.4			40	55
68256	Phelon	FG8635	2.6			58	69
68716	Wico	X18050	1.5	.7	.9	45	55
69323	Phelon	FG6240-N	2.7			55	65

HOMELITE (Continued)
CONDENSER SPECIFICATIONS

<u>Homelite Number</u>	<u>Vendor Name</u>	<u>Vendor Number</u>	<u>Capacity Reading In Microfarads</u>	
			<u>Min.</u>	<u>Max.</u>
32091	Wico	X7228	.16	.20
63250	Wico	X-16329	.16	.20
64086	Wico	X16835	.16	.20
65286	Phelon	FG8589	.15	.19
68711	Wico	X18042	.16	.20
76419	Wico	X11672	.16	.20

HUSQVARNA
IGNITION COIL SPECIFICATIONS

<u>Coil No.</u>	<u>Operating Amperage</u>	<u>Primary Resistance</u>		<u>Secondary Continuity</u>	
		<u>Min.</u>	<u>Max.</u>	<u>Min.</u>	<u>Max.</u>
*2 204 211 052	1.6	1.8	2.5	40	55
2 204 211 069	1.5	1.0	1.4	45	55
2 204 211 079	1.5	1.0	1.4	45	55
50 14 659-01	1.4	1.4	1.9	40	50
50 15 410-01	3.0	.3	.5	25	35
BZ 30/6	1.3	1.2	1.6	45	60

*When testing this coil use C.D. Adaptor #55-980.

CONDENSER SPECIFICATIONS

<u>Condenser No.</u>	<u>Capacity Reading In Microfarads</u>	
	<u>Min.</u>	<u>Max.</u>
6 913 28	.15	.20
1 237 330 035	.15	.20
2 207 330 041	.15	.20

INDIAN MOTORCYCLE
IGNITION COIL SPECIFICATIONS

<u>Coil No.</u>	<u>Operating Amperage</u>	<u>Primary Resistance</u>		<u>Secondary Continuity</u>	
		<u>Min.</u>	<u>Max.</u>	<u>Min.</u>	<u>Max.</u>
23001168	1.7	1.0	1.4	45	55
92005011	1.7	1.2	1.6	40	50

PRIMARY IGNITION COIL WINDING

<u>Coil No.</u>	<u>Primary Resistance</u>	
	<u>Min.</u>	<u>Max.</u>
23001162	1.2	1.6
23005012	.4	.8
92005002	0.95	1.3

INDIAN MOTORCYCLE (Continued)

LIGHTING COIL			CHARGING COILS		
Coil No.	Primary Resistance		Coil No.	Primary Resistance	
	Min.	Max.		Min.	Max.
23005008	.1	.2	23005010	Test with coils hooked together	
23005009	.1	.2	23005011	.15	or less
Test with coils hooked together					
23001163	.2	.4 grounded	CONDENSER SPECIFICATIONS		
92005004	White-Ground .1	.3	Capacity Reading		
	White-Red .1	.2	In Microfarads		
	Red-Ground .15	or less	Condenser No.	Min.	Max.
92006002	.1	or less	23001166	.25	.32
			92005008	.14	.18

JONSEREDS CHAIN SAW-TILTON EQUIPMENT IGNITION COIL SPECIFICATIONS

Coil No.	Operating Amperage	Primary Resistance		Secondary Continuity	
		Min.	Max.	Min.	Max.
391001	2.3	.4	.6	25	35
L-39022	1.2	1.0	1.4	50	65
M-100690	2.0	.4	.6	50	60
T-9408H	1.4	.6	.8	40	55

IGNITION GENERATOR COIL			CONDENSER SPECIFICATIONS		
Coil No.	Primary Resistance		Condenser No.	Capacity Reading	
	Min.	Max.		Min.	Max.
391302	.4	.6	L-39023 Assembly	.15	.20
			M-100680 Assembly	.15	.20
			T-643A31 Assembly	.15	.20

KIORITZ CORPORATION OF AMERICA ECHO CHAIN SAWS SEARS CRAFTSMAN CHAIN SAW IGNITION COIL SPECIFICATIONS

Kioritz Coil No.	Operating Amperage	Primary Resistance		Secondary Continuity	
		Min.	Max.	Min.	Max.
150126-0033-0	1.4	.7	1.0	45	60
150126-0111-0	1.5	.4	.7	35	50
150126-0393-0	1.8	.5	.75	50	65
152126-0333-0	2.0	.4	.7	40	50
153126-0283-0	1.5	.6	.85	40	55
153126-0373-0	1.5	.6	.85	40	55
154126-0343-1	1.8	.5	.8	40	50
156126-0373-0	1.5	.6	.85	40	55

KIORITZ CORPORATION OF AMERICA (Continued)

**IGNITION PRIMARY COIL
WINDING SPECIFICATIONS**

Coil No.	Primary Resistance	
	Min.	Max.
18000460	1.1	1.5
18000461	1.1	1.5
18000462	1.4	2.0
18000720	1.1	1.5
18000721	1.1	1.5
18000722	1.1	1.5
18000723	1.4	2.0
19000260	1.3	1.7
25000410	1.0	1.4
25000412	1.2	1.6

KIORITZ ENGINE (Formally CCW)

Coil No.	Operating Amperage	Primary Resistance		Secondary Continuity	
		Min.	Max.	Min.	Max.
18000650	.5	1.4	1.8	40	50
18000651		1.4	1.8	40	50
18000800	.5	1.4	1.8	40	50
18000801		1.4	1.8	40	50
19000500		.6	1.0	50	60
19000541		.6	1.0	50	60
25000520		.3	.5	50	60
25000522		.3	.5	50	60
25000530		.3	.5	50	60
25000532		.3	.5	50	60

LIGHTING COIL WINDING SPECIFICATIONS

CONDENSER SPECIFICATIONS

Lighting Coil No.	Primary Resistance		Condenser No.	Capacity Reading In Microfarads	
	Min.	Max.		Min.	Max.
18000470	.4	.6	150127-0033-0	.18	.24
18000471	.75	1.0	150127-0091-0	.18	.24
18000472	.75	1.0	150127-0393-0	.16	.20
18000473	.1	.3	152127-0333-0	.18	.22
18000474	.1	.3	153127-0283-0	.16	.22
19000270	1.3	1.7	154127-0343-0	.16	.20
25000420	.8	1.0	156127-0373-0	.18	.22
36001380	.1	.3	18000490	.22	.30
36001381	.15	.35	18000491	.16	.22
			18000492	.16	.22
			18000740	.22	.30
			18000741	.16	.22
			19000280	.19	.27
			19000480	.19	.27
			25000430	.23	.31
			25000460	.23	.31
			36001320	.22	.28
			36001321	.26	.34
			36001322	.26	.36
			36001330	.22	.28

**KOHLER
IGNITION COIL SPECIFICATIONS**

Coil No.	Operating Amperage	Primary Resistance		Secondary Continuity	
		Min.	Max.	Min.	Max.
277375	1.5	4	6	70	80
275213	1.7	2.5	2.6	35	45

**MALLORY
IGNITION COIL SPECIFICATIONS**

Coil No.	Primary Resistance		Secondary Continuity	
	Min.	Max.	Min.	Max.
28880	.1	or less	10	20
28900	1.9	2.6	20	30
29150	.7	.9	10	20

**OMC - EVINRUDE & JOHNSON
IGNITION COIL SPECIFICATIONS**

Coil No.	Operating Amperage	Primary Resistance		Secondary Continuity	
		Min.	Max.	Min.	Max.
112931	.8	1.5	1.7	60	70
*581370	1.7	.8	1.2	60	70
*581407	1.7	.8	1.2	60	70
*581503	2.1	.1	or less	15	25
*581609	2.1	.1	or less	15	25
*581610	2.1	.1	or less	15	25

*When testing this coil use C.D. Adaptor #55-980.

Coil No.	Primary Resistance	
	Min.	Max.
581130	.6	1.0
5812022	1.0	1.9
581557	2.2	3.2

CONDENSER SPECIFICATIONS

Condenser No.	Capacity Reading In Microfarads	
	Min.	Max.
581419	.25	.29

**ONAN
IGNITION COIL SPECIFICATIONS**

Coil No.	Operating Amperage	Primary Resistance		Secondary Continuity	
		Min.	Max.	Min.	Max.
**166B 535	.9	3.0	5.0	65	75
*166 278	1.5	2.5	3.75	60	70

* When testing this coil use C.D. Adaptor #55-980.

** Model 98, use 12 volt storage battery or equal for coil power test only. Disconnect internal battery and connect analyzer battery leads to a 12 volt storage battery or equal. Do not use 12 volts for any other tests as reading will be incorrect. Connect to 12 volt storage battery or equal and place selector switch in the 12 V position.

**PHELON
CONDENSER SPECIFICATIONS**

Condenser No.	Capacity Reading In Microfarads	
	Min.	Max.
FG 9072	.15	.19
FG 9221	.15	.19

**POLARIS
IGNITION COIL SPECIFICATIONS**

Coil No.	Operating Amperage	Primary Resistance		Secondary Continuity	
		Min.	Max.	Min.	Max.
*3080838	1.7	1.4	1.8	40	50
*3081177	1.9	1.4	1.8	40	50
*3081272	1.7	1.4	1.8	40	50
***3081303	2.0	.35	.45	55	65
**3081389	2.7	.15	or less	20	30
3081573	1.9	.1	.2	45	55
3081603	1.2	.5	.7	60	70
***3081627	2.0	.35	.5	55	65
*3081974	1.7	1.4	1.8	40	50
3081980	1.6	.1	.2	45	55

* Disconnect internal battery and connect battery leads from analyzer to a 12 volt storage battery or equal. This test is for COIL POWER TEST ONLY. DO NOT USE THE 12 VOLTS FOR ANY OTHER TEST AS READING WILL BE INCORRECT.

** When testing this coil use C.D. Adaptor #55-980.

*** There is no continuity between primary and secondary leads, however, continuity is between secondary leads. See page 23, Figure 26 in manual for test procedure.

CONDENSER SPECIFICATIONS

Coil No.	Capacity Reading In Microfarads	
	Min.	Max.
3081133	.22	.27
3081569	.24	.30
3081732	.24	.28
3081970	.22	.27

**PRESTOLITE (WICO)
IGNITION COIL SPECIFICATIONS**

Coil No.	Operating Amperage	Primary Resistance		Secondary Continuity	
		Min.	Max.	Min.	Max.
*FAC3004	1.4	.1	or less	5 (100-300 ohms)	Approx.
*FAC3006	1.4	.1	or less	5 (100-300 ohms)	Approx.
FWM10355	1.6	.7	.9	45	60
FWM10385	1.9	.4	.6	45	60
FWM2003	1.5	.6	.8	45	60
FWM3003	1.9	.55	.75	40	55
FWM3005	1.8	.5	.7	40	50
X17462 C	1.5	.7	.9	45	60
X17818	1.4	.6	.8	40	55
X17865	1.4			40	55
X18015	1.4			40	55
X18050	1.5	.7	.9	45	55
X18122 B	1.7			12	18
X18128	1.6			40	55
X18163	1.6			40	55
X18248 S		.35	.55	45	60

*When testing this coil use C.D. Adaptor #55-980.

CONDENSER SPECIFICATIONS

Condenser No.	Capacity Reading In Microfarads	
	Min.	Max.
17895	.16	.20
FWM1024	.16	.20
X17767	.16	.20
X17979	.16	.20
X18042	.16	.20
X18059	.16	.20

**ROBIN SPECIFICATIONS
IGNITION COIL SPECIFICATIONS**

Coil No.	Operating Amperage	Primary Resistance		Secondary Continuity	
		Min.	Max.	Min.	Max.
1297013008/EC07-2G	1.4	.65	.85	30	45
*H4Q-396/EC 17F	.9	1.4	1.8	45	55
*H4S-434-2/EC 10G	1.5	.8	1.2	55	65

* Model 98 use a 12 volt storage battery or equal for coil power test only. Disconnect internal battery and connect analyzer battery leads to a 12 volt storage battery or equal. Do not use 12 volts for any other tests as reading will be incorrect. Connect 12 volt storage battery or equal and place selector switch in the 12 V position.

MODEL 98A Connect to 12 volt storage battery or equal and place selector switch in the 12 V position.

**STIHL AMERICAN, INC.
IGNITION COIL SPECIFICATIONS**

Coil No.	Operating Amperage	Primary Resistance		Secondary Continuity	
		Min.	Max.	Min.	Max.
2 204 211 052	1.6	1.8	2.5	40	55
2 204 222 022	1.2	.8	1.2	55	65
*FG943	1.6	.7	1.1	50	60

*When testing this coil use C.D. Adaptor #55-980.

CONDENSER SPECIFICATIONS

Condenser No.	Capacity Reading In Microfarads	
	Min.	Max.
2207330041	.16	.22
FG9072A	.15	.20

**TECUMSEH PRODUCTS CO.
IGNITION COIL SPECIFICATIONS**

Coil No.	Operating Amperage	Primary Resistance		Secondary Continuity	
		Min.	Max.	Min.	Max.
610633	1.8	.4	.6	40	50
*610785A	1.55	to low	to read	5	8
610747	} When testing these coils use C.D. Adaptor #55-700				
610748					
610749					
610759					
610774					
610775					
610784					
610803					
610815					
610831					
610844					
610851					
610851A					
610873					
610906					
610910					
610958					

*When testing this coil use C.D. Adaptor #55-980

CONDENSER SPECIFICATIONS

Condenser No.	Capacity Reading In Microfarads	
	Min.	Max.
32079	.18	.23
610161	.18	.23
610416	.16	.20

**TILTON EQUIPMENT COMPANY
IGNITION COIL SPECIFICATIONS**

<u>Coil No.</u>	<u>Operating Amperage</u>	<u>Primary Resistance</u>		<u>Secondary Continuity</u>	
		<u>Min.</u>	<u>Max.</u>	<u>Min.</u>	<u>Max.</u>
*391002	1.5	.4	.6	25	35

*When testing this coil use C.D. Adaptor #55-980.

CONDENSER SPECIFICATIONS

<u>Condenser No.</u>	<u>Capacity Reading In Microfarads</u>	
	<u>Min.</u>	<u>Max.</u>
100680	.15	.19
L39023	.15	.19