

The ANTIQUE OUTBOARDER

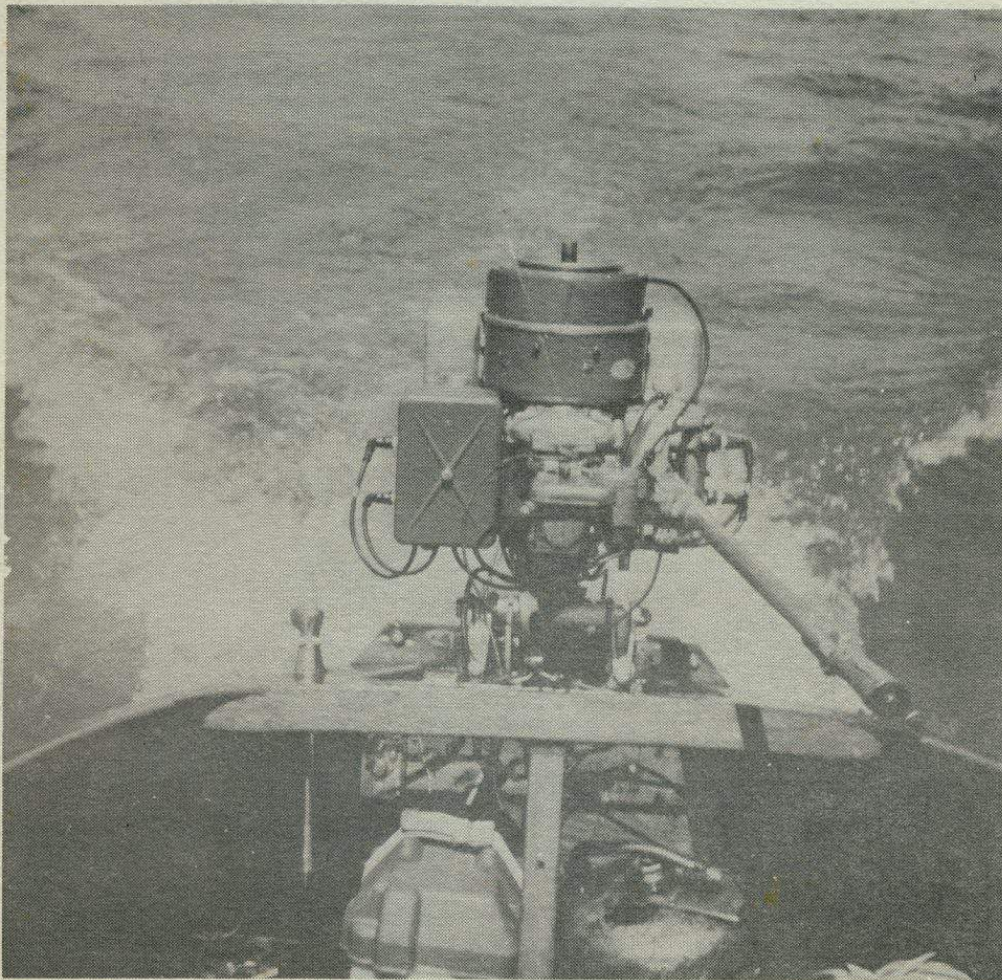
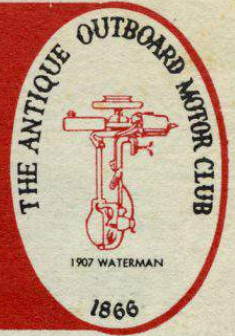

1930 - THE YEAR OF THE ELECTRIC START

VOLUME 3

NUMBER 1

JANUARY, 1968

The Antique Outboard Motor Club

SPECIAL MEMBERS

SPONSORING [\$100.]

KIEKHAEFER CORPORATION, Fond du Lac, Wisconsin

ASSOCIATE [\$50.]

EVINRUDE MOTORS, Milwaukee, Wisconsin
RALPH EVINRUDE, Jensen Beach, Florida

CONTRIBUTING [\$25.]

THE BIG W OUTBOARD MOTOR MUSEUM, Lake Winnepesaukee, Wolfeboro,
New Hampshire

These members have contributed to the club's growth and activities through the purchase of a Special Membership. In recognition and in appreciation, they are so listed.

The Antique Outboard Motor Club



SWEATSHIRT



These high quality shirts are imprinted with the official club emblem. Order yours in S-M-L-XL; black or burgundy with white emblem; short or long sleeves.

PRICE: \$4.95 each p.p.

Send check and information to

Tom Zimmer
390 Sherwood Lane
Algonac, Michigan

Mark (l.) and Mike Zimmer with Dad.

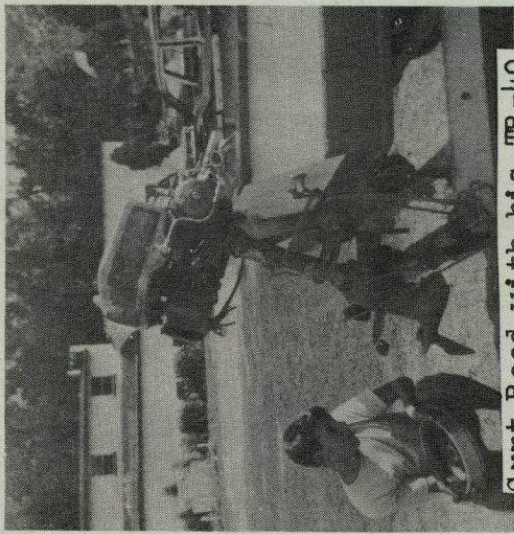

Curt Reed with his TR-40 with broken prop.

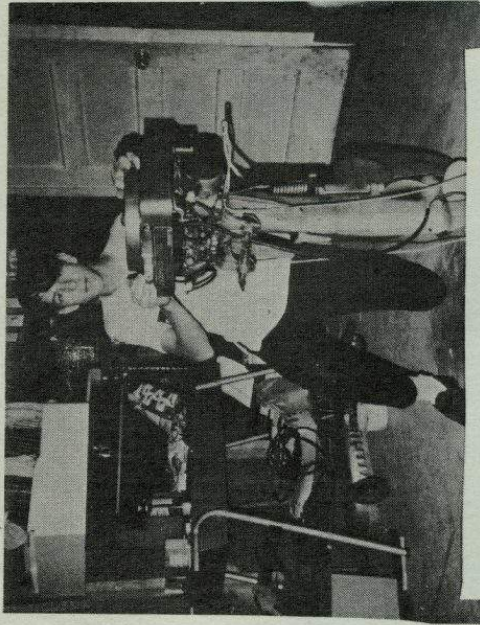

Ray Machen with Elto.

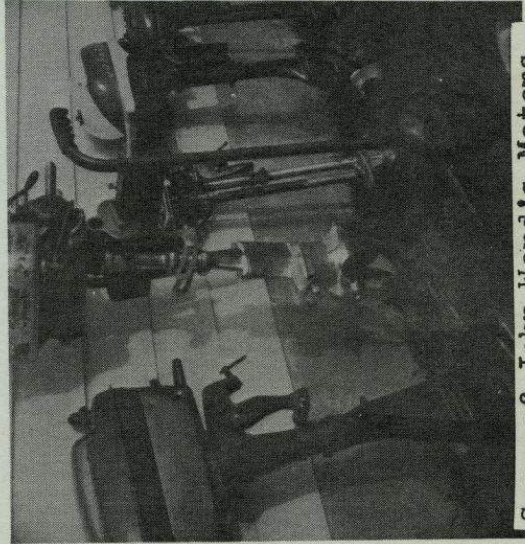

Some of John Ward's Motors.

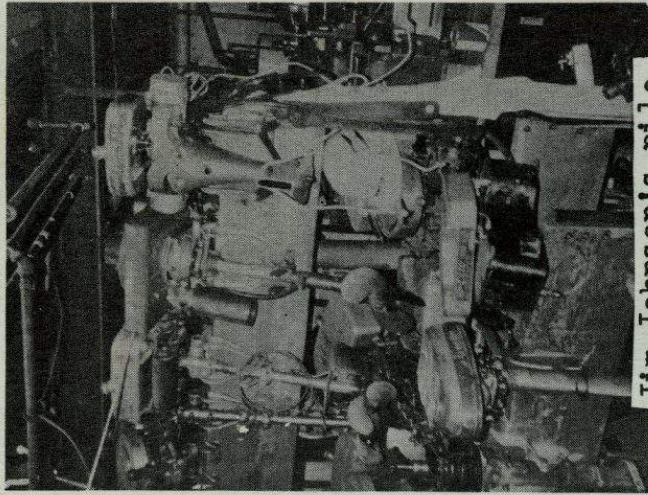

Jim Johnson's pile.

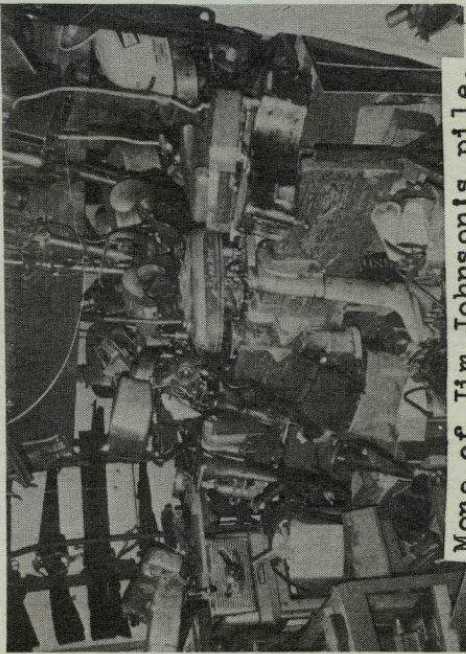

More of Jim Johnson's pile.

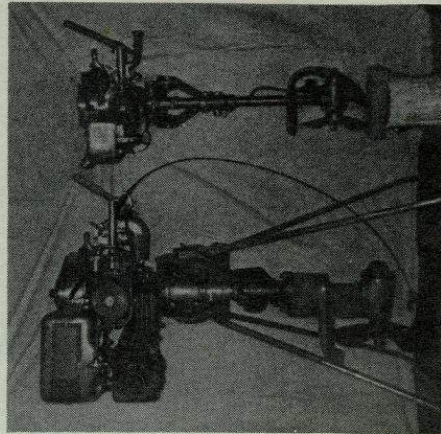

Curt Reed's TR-40 and A-25.

THE ANTIQUE OUTBOARDER

Volume 3 **contents** number 1

THE 1930 JOHNSON VE-50, Electric Start.....	1
D. R. Reinhartsen	
TEST REPORT, 1930 Elto Senior Speedster.....	7
W. M. Kelly	
FROM ATTIC TO ANTIQUE.....	9
W. T. Salisbury	
NOTES FROM THE CURATOR.....	12
R. A. Hawie	
MOTOR COMPARISON, A 1928 Johnson vs a 1957 Johnson.....	15
J. Ward	
ANTHEA IN OUTBOARDLAND.....	17
A. T. Aitken	
NEW MEMBERS.....	18
FROM THE WEIDMAN COLLECTION.....	19
W. Weidman	
THE EDITOR'S CORNER.....	20
D. R. Reinhartsen	
TRADER'S COVE.....	22
R. H. Zipp	

copyright 1967



T.A.O.M.C.

The Antique Outboarder

is an official publication of The Antique Outboard Motor Club.. The first issue was printed in January of 1966, and succeeding issues are mailed in January, April, July and October. The Antique Outboard Motor Club was organized in October, 1965, and is beyond any doubt, non-profit. The club is devoted to people all over the world who are interested in these fascinating engines, their restoration and their preservation. Club headquarters: 1107 Pueblo Drive, Richardson, Texas, 75080.

Club officers, addresses and duties:

David R. Reinhartsen, President: 1107 Pueblo Drive, Richardson, Texas. Coordination of club activities and preparation of the Antique Outboarder.

Christopher R. Owen, Vice-President and Test Editor: Route 3, Eau Claire, Wisconsin. Maintains the antique outboard motor registration file and runs lake tests of antique motors.

John C. Harrison, Treasurer and Technical Advisor: 1000 NW. 54th Street, Miami, Florida. Reviews financial reports and gives advice on motor restoration.

Carole R. Reinhartsen, Secretary: 1107 Pueblo Drive, Richardson, Texas. Keeps records, etc.

Richard A. Hawie, Curator: 31 Hillside Drive, Easton, Connecticut. Helps in identification of rare motors and prepares a column Notes From The Curator.

W. J. Webb, Historian: 2560 North 97th Street, Wawatosa, Wisconsin. World's foremost authority on outboard history. Author of a column Of Historical Interest.

James L. Smith, Special Features Editor: 330 O'Connor Drive, Toronto, Ontario, Canada. Preparation of special articles on unusual motors.

Lorne Douglas, Membership Coordinator: 73 Deer Lodge Place, Winnipeg 12, Manitoba, Canada. Ray Machen, Membership Coordinator: 624 Gardner Road, Westchester, Illinois. Distribution of club literature.

Hal Copeland, Public Relations Director: 1904 Tower Petroleum Building, Dallas, Texas. Public Relations.

Robert Zipps, Classified Editor: 24A St. Regis Street, East Hartford, Connecticut. Management of the classified section.

Bud Cowdery, Racing Editor: 48 Farm Street, Danbury, Connecticut. Preparation of a column on the early days of outboard racing.

Anthea T. Aitken, Membership News: 503 North Waterview, Richardson, Texas. Anthea tells us all what we all are doing.

Marcus Wright, Parts Aquisition: 30 Crest Drive, Little Silver, New Jersey. Helps members find parts needed in their restoration projects.



THE 1930 JOHNSON VE-50

ELECTRIC START

D. R. REINHARTSEN

* Special thanks go to members John Harrison, W. J. Webb, R. H. Watkins and Marcus Wright, all of whom have aided me in preparation of this report.

The motors of the racing era are especially fascinating to many of our members. During the late 20's and early '30, high power motors and high speed boats permitted speed upwards of 50 mph. Imagine how it thrilled a public which was used to speeds of less than 15 mph. These high horsepower engines were harder to start. Therefore, in order to appeal to a greater number of buyers, what was then the big three - Evinrude, Johnson and Lockwood - began looking for a bolt-on electric start unit which could be used on their larger motors. The Owen-Dyneto Company of Syracuse, New York, made a starter-generator unit which seemed ideal, and the big three turned to Owen-Dyneto for its development.

HISTORY

When queried about the history of the Owen-Dyneto unit, Outboard Historian W. J. Webb replied;

"About Owen-Dyneto, here is how I remember it:"
"The sum total of my knowledge on the subject is that for some years, from about 1915 until WW II, they made a starter generator unit for Packard and some of the less well-favored cars. Although Packard was certainly not too well-favored after the teens. Jordan was another of them, I believe. Anyway, come 1929 and we are looking for a starter unit for outboards per Mrs. Evinrude's oft repeated request, and Ole happens to think of the starter generator unit in his Packard. So they call in the Owen-Dyneto guy. He is sworn to secrecy, he agrees, so right after he left us, he stops in Waukegan. Anyway, we try out the Owen-Dyneto unit in the fall when the weather is cool to cold. We overlooked two very important things. First, the automobile engines of that day never get above maybe 2500 rpm. And while the normal operation of an auto can

raise the operating temp of the starter-generator unit a maximum of 180 degrees above atmospheric; it never gets that high because then, as now, cars just don't travel at peak RPM's 95 percent of the time the way outboards do. Also, while testing in the fall the ambient temp was probably not over 50, usually lower. So add 180-200 to 50 and you get a top temperature still below the point where solder and other fastening components such as varnish and insulating glues would not soften and let the wire windings loosen. But take summer temps and the critical point was passed with the result that solder and other stuff would soften with the result that suddenly you had a rat's nest inside the unit. Damndest mass of wire you ever saw.

Then auto engines never did run in salt water. And the Owen-Dyneto unit was not designed against the ravages of salt water. So, away went the switches, the terminals and what not. And what those higher RPM sometimes did to generator loads and burned points! Sometimes the batteries would boil.

So besides getting a fatal black eye in 1930, the starter-generator people never did make a real try at correcting engineering problems. We did what was done. By 1935 the starter generator unit wasn't too bad but it never came back, partly because of that bad first year and partly because it cost too much for the economy of those days.

Owen-Dyneto went out of business in the late 1930's. Or maybe before that. The Dun's book quit listing them long ago.

The reasons for failure of their Electric Start Unit in the outboard was that it was put into a service for which it was not designed, and no real attempt was ever made to correct it. We did the best we could, but in those days we did not have the money for the extensive research needed, and all of us recognized that this horse was pretty dead and that what was needed was a whole new 'from-the-ground-up design.'

Others, when asked for comments, were less kind. One member, on hearing that I had one of these units, suggested that the best thing to do would be to take it off. Still another said, "I've never seen one work yet! What a challenge!

In any event, in the spring of 1967 one was sent to me through the generosity of a member who, on hearing that I had a Johnson V-50, thought that it should be a VE-50, the E designating Electric Starting. "Besides," he said, "if anyone can make it work, you can."

DESCRIPTION

The Owen-Dyneto is a bolt-on rotor and field assembly which replaces the flywheel and magento assembly. A breaker assembly is also mounted on the motor to interrupt the externally mounted coils. The coils incidently were made by the P.R. Mallory Co.,

still famous for their ignition systems. An exploded view of the entire assembly is shown in Figure 1.

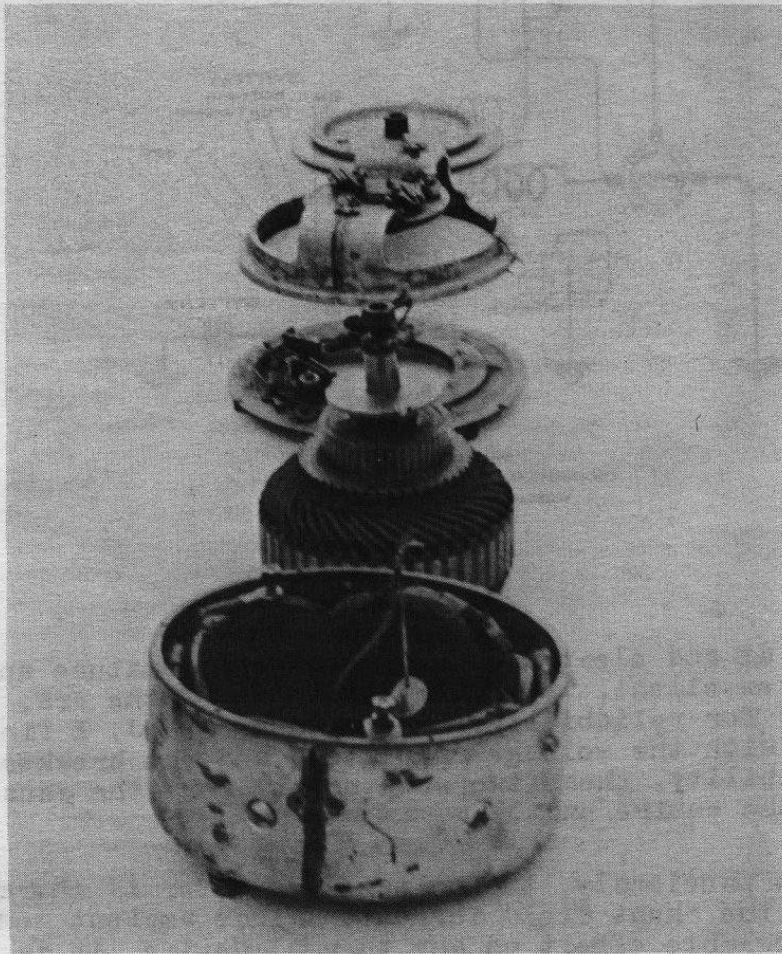

Figure 1

Electrically, the field assembly has two windings on it, a series or starter winding, and a shunt or generator winding. When operated as a starter, the series winding and the armature are connected across the battery by means of a switch. This draws (initially) a fantastic 290 amperes from the six volt battery, and develops only 27 foot pounds of starting torque. Once the engine reaches a cranking speed of 400 rpm, torque output is four foot pounds at a current of 65 amperes. From cranking speed to 1000 rpm, the Owen-Dyneto unit supplies power to the propeller so that the outboard acts much like a gasoline-electric. Above 1000 rpm, the Owen-Dyneto unit acts like a generator, recharging the battery. (By this time the poor battery probably needs it!)

Believe it or not, the voltage regulator is thermally actuated! A bimetallic strip is wound with a fine wire, through which the generator field current of up to six amperes flows. Increasing field current causes the strip to bend, cutting in a field resistor, thus, lowering the charging rate. The charging rate is, by the way, set at a maximum of 16 amperes. The original circuit diagram is shown in Figure 2.

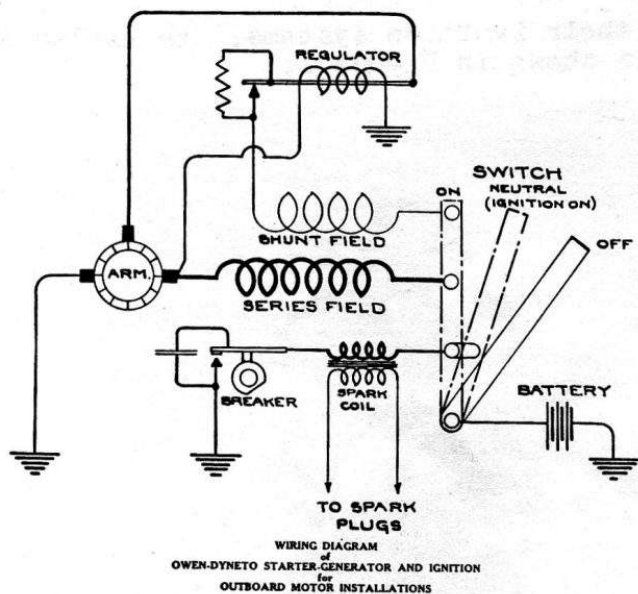

Figure 2

The mechanical and electrical design of the armature and field assembly is excellent. Like all machinery of the era, it is overdesigned for reliability. On the other hand, I find particular fault with the voltage regulator, and the breaker assembly. In all probability, these two weak points were the cause of the failure of the entire unit.

As mentioned previously, the voltage regulator is thermally actuated by the shunt field current. Since ambient temperature has a considerable effect on any thermal device, it is not surprising that the charging rate would change with ambient temperature. Then, too, the generator was a three-brush type, ie one which uses the generator's magnetic non-linearities to help control the charging current. Characteristically, three-brush generators charge a discharged battery at a lower rate than one which is fully charged. Also, three-brush generators charge at a lower rate at high engine speeds. For example, the specifications for this unit are 16 amperes at 2500 rpm and 13 amperes at 4500 rpm.

Another fault lies in the breaker assembly. Because of the mechanical construction, the engine has to be re-timed each time that work is done on the Owen-Dyneto unit. Also, current is carried to the points by a sliding contact, and that never works well under the conditions to which an outboard is subjected.

Finally, the electrical circuit design is certainly not the best- it just doesn't make sense to leave the battery connected to the starter once the engine has started. A simple relay could disconnect it. What is powering the boat anyway, gasoline or electricity?

MODIFICATIONS

Now I really hate to modify a motor, because I'm of the opinion that a restored motor should look just like it did the day it left the factory. On the other hand, I also believe that these motors should be run and used like any modern motor. Hidden modifications are certainly permissible, and in this case needed. A simple flexible copper braid takes the place of the sliding contact in the points assembly, a starter solenoid from a '54 Ford takes the place of the old starter switch, and a modern transistorized voltage regulator circuit replaces the old thermally actuated device (Figure 3). The result is a starter that works very well, and a generator which charges to a 15 amp rate. Starting is accomplished with the twist of a key.

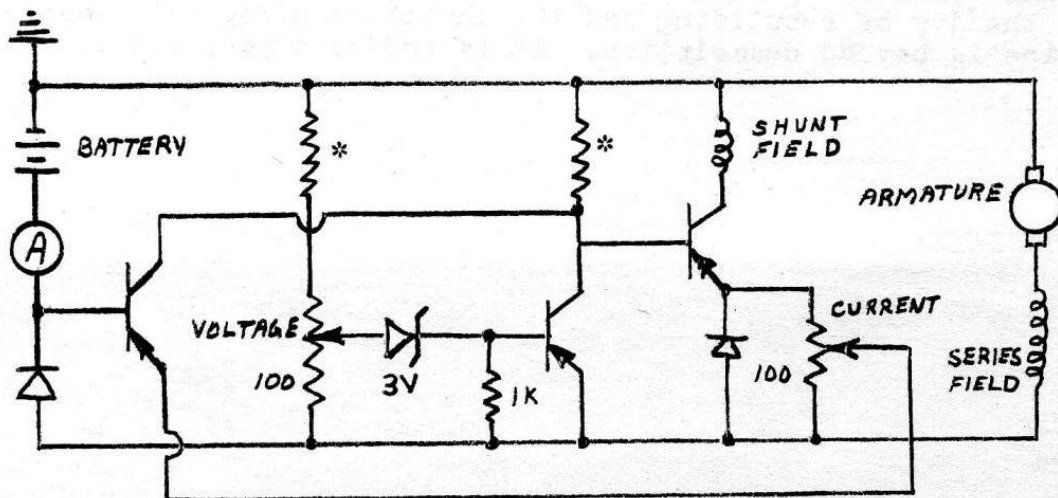

* chosen for individual transistors.

THE ENGINE

Johnson brought out their first four cylinder model #V-45 in 1929. This was a 40 cubic inch engine, which, when set up for racing, developed 32 hp. The standard model develops 26 hp. Model V-50 was offered to the public in 1930, and it develops 26.1 hp (stock). The only changes were a 1:1 rotary valve assembly, and a crankcase casting which had lips for mounting an electric start assembly. The connecting rod bearings were changed, also, because the 1929 rollers were too few and too short, resulting in extremely rapid crankshaft wear. As a matter of fact, V-45 and V-50 crankshafts are nearly impossible to find nowadays because the wear problem continued 'til the V series was discontinued.

TEST RESULTS

The VE-50 is a pleasure motor, but not a fishing or racing motor. Its 199-pound weight and bulk are such that it is best to leave the motor on your boat and not even attempt to take it off. Starting, with the electric start unit, is a real pleasure; close choke, close release charger, open the throttle halfway and advance the spark slightly; then turn the key, open the choke and release charger once the motor "catches." The engine starts quite readily, in slightly more time than it takes to start your car, and once underway runs very smoothly.

Idling is very smooth. However, the low speed torque is very poor. In tests of both a V-45 and a VE-50, I had considerable difficulty getting the boat off on a plane. In the case of the V-50, the 12" X 12" prop had to be repitched to 10" in order to get the boat moving. Once off on a plane, however, performance approached that of a 1938 Johnson 22 hp. That sounds funny, I know, but my 1938 22 hp performs better than either of the 1929 or 1930 26 hp. In fairness to the VE-50, it should be stated that the generator is taking about $\frac{1}{4}$ hp to recharge the battery. But still, performance is disappointing in comparison to other engines of the era.

To my knowledge, this is one of about 10 V-50's in existence. It is one of two in use, and is the only pre-war, electric start engine which is operable today. The engine may lack performance, but the joy of rebuilding and the thrill of using this rare engine is beyond description. It is indeed a rare classic.



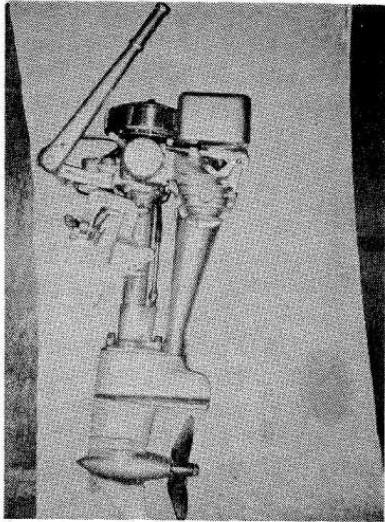

Test Report

1930 ELTO SENIOR SPEEDSTER

W.M. KELLY

The ELTO "Senior Speedster" of 1930 was the largest two-cylinder engine that had as yet been offered under the marque. At the time, outboard motors were undergoing a transition almost as great as the one of the late 40's. Just four years previously, Johnson's P-30 went screaming through the traps at a fantastic 16 mph, beginning a horsepower race which eventually resulted in engine horsepower comparable with today's. The 1930 Elto was built during the time of transition from luggers to high-speed units, and has features of both types.

The particular model for this article is a model 310, the standard type motor. Also listed were a model 311 electric start, and a 312 and 313, which were standard and electric respectively, with longshaft lower units.

The fuel system on the Senior utilizes a two-poppet valve, float-feed carburetor with a gravity-feed float bowl. The poppet valves are raised from their seats by crankcase vacuum - the fuel is merely sucked into the system from a hole in each seat. The hole is sealed on the power stroke. Only one metering adjustment is provided for the full range. Fuel mixture flows from the crankcase to the cylinders by piston-ported transfer passages. Exhaust is at the back of the cylinders, into a generously proportioned muffler can; it then proceeds downward through a tapered exhaust pipe and out (underwater) through the cavitation plate.

Powerhead bearings are a combination of friction and nonfriction types, with roller-bearing crankpins, and sleeve-type wrist pins and mains.

The lower unit on this motor was a new design, well engineered and streamlined. It makes generous use of ball bearings throughout, although there is a sleeve bearing at the top of the driveshaft and at the outer end of the propshaft - probably to help control loss of grease. This unit was continued for quite a few years and appears on many other models.

TEST RESULTS

Although this engine is nearly as big as the later speeditwin models, it is deceptively light and can be handled easily. Set up on the boat, the size diminishes somewhat and the engine looks very trim.

For priming purposes, a spring-loaded pin is provided to the right-hand poppet valve. When this pin is depressed it raises the valve off the seat. This allows fuel to be sucked into the crankcase by "bouncing the flywheel off compression" a few times.

This particular test engine is equipped with an adapted flywheel magneto. The original arrangement was a battery system, with the typical Elto knob-on-flywheel starting. The difficulty and danger in using this method for starting an engine of this size is obvious. At sometime in the past, a magneto from a Johnson S-45 was adapted by means of several spacers on the crankcase neck. The flywheel fits perfectly. Not stock, but an excellent compromise.

Several full pulls are required to prime the cylinders, then you are underway. The noise level is low at slow-to-intermediate speeds, because of the underwater exhaust. The only objectionable sound is the clicking of the poppets on their seats. As the speed increases the poppet noise also gets higher pitched. The sound of the engine is completely unique at higher speeds. One must use discretion in advancing the spark. The carburetor-valving system is purely a function of vacuum; a too rapid advance of the spark will actually slow you down. It will also, on occasion, provide a nice backfire - very spectacular, but requiring a reprime and restart!

Top speed of the unit is exceptional. I was able to read 34 mph on my A-B utility, using a two-blade racing wheel (whose origins, pitch and diameter are lost in antiquity). It takes a while to approach this speed and the addition of a passenger knocked it down to only 28 mph. It appears that the power aspect of the engine leaves something to be desired; the idle was poor also. This engine was certainly not designed for fishing. The Senior is a well constructed and competitive engine for its time, but does not combine power and speed, as did some of its competition of similar displacement. As it had 25 cu. in. displacement and didn't fit into any racing class, it was superceded by the 30 cu. in. Speeditwins and Super "C". Discontinued after 1934, it became only a memory. Today it can be enjoyed once again by members of the Antique Outboard Motor Club, who seek to re-create those early days.



NEW ADDRESSES

Bud Cowdery, 15 Crestdale Road, Danbury, Connecticut 06810
Charles E. Henderson, P.O. Box 43, Telfernan, Texas
T. J. Zimmer, P. O. Box 186, Algonac, Michigan 48001

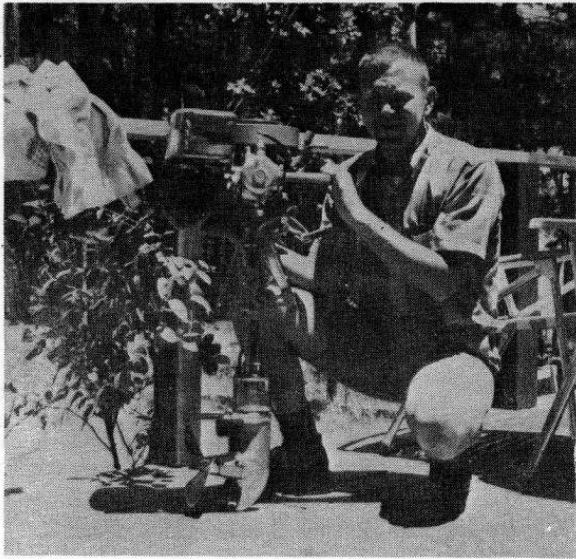

From Attic To Antique

W. T. Salisbury

Behind my father's house was a tool shed, and at the age of three that shed played a very important part of my life. It was filled with all sorts of good things of interest and among the most important was the outboard motor which could be found in the corner behind the door.

This outboard motor was a large one because it was bigger than I. It keeps re-appearing throughout my childhood and I was always thrilled when our activities had the motor included.

As I grew older, I learned that this motor was a Johnson Sea Horse, Model 100 and developed some unknown horsepower. Not until only a few years ago did I find out that it was built in 1936 and it produced 1.7 horsepower.

As the years went by, we used that motor many times on a lake in Vermont near my grandfather's house. It provided many hours of pleasure and amusement, the latter because of its ability to become balky at the most inopportune times. Sooner or sometimes much later it would run and return us to the boat dock with our catch of fish, ending another chapter in its life.

I have always kept track of that motor's whereabouts and have let it be known many times that I would like to have it for my own, but it is in the hands of a relative now and it apparently means something to him too, because he absolutely will not give it up.

This digression brings me to the point of this article. Several years ago I began to collect old outboard motors. The "square tankers" always were and still are very fascinating. I have always kept one eye open for a Johnson Model 100, but to date have not found one.

One day as I was coming near the end of my restoration project of my Evinrude Speedifour, I was browsing around the boat shop in which I had worked for several years. The present owner knew I was interested in old outboards and said that he had something for me.

In the back of the shop was an old Johnson. I could hardly get to it fast enough. The model number identified it as an F-75 and from my memory I estimated it to be of about 3.3 horsepower. This poor old motor had, without a doubt been through the wars and plenty of salt water. Its cylinders were rusty, its tank dented, its lower unit and propeller pitted, its muffler replaced by one of its many alleged previous owners with one made out of brass to match the original, and finally the hub of its flywheel broken out. Someone had attempted heliarc welding the hub back together but had unfortunately not been able to do so without causing the wheel to run out of true. The final, resulted in the magnet hitting the stator preventing the motor from revolving. Its limited arc of travel did prove, at least, that the old Johnson was free inside.

I wanted it, and right now! I asked the shop owner what he wanted for it. He said he had been saving it especially for me and that he would take \$15.00 for it. I told him that it wasn't worth anything in its present condition. He said he knew that but that I could probably use it for parts, and that he could get \$5.00 from the junk man. To make use of an old cliché, "making a long story short", I walked out of the shop with my F-75 after paying \$2.00 for it.

I rushed it home and laying aside the work on my Speedifour, I began to tear into it to see what I needed, also to check the lower unit for water inside (there wasn't any, only grease) so that I could order the necessary parts and lay it aside until later, assured that no more damage would be done by just sitting.

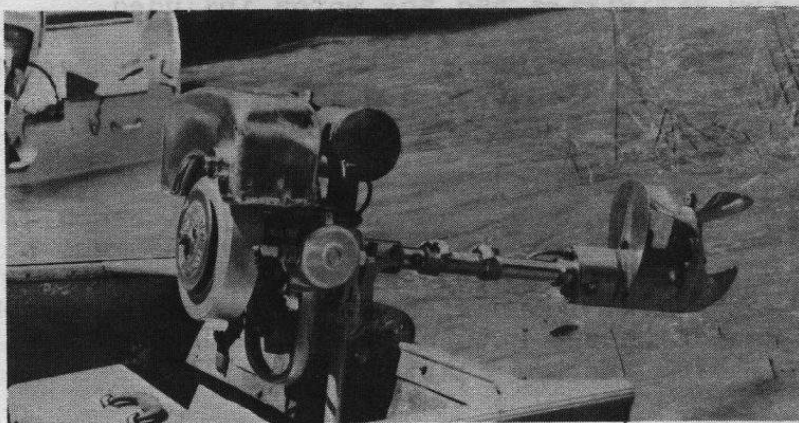

Then it happened, I changed jobs and we moved from New Jersey to California in a big hurry and the little F-75 was left behind with the rest of my collection in my father's basement. During this curcial period the repair parts arrived but remained unopened as my hobby was temporarily side tracked.

About one year later we made a visit to New Jersey and one of the first places I went to was my father's basement. Yes, it was all there. I had a new flywheel for the F-75!

I packed the disassembled F-75 in a box and took it back to California with us. Inside about $2\frac{1}{2}$ hours I had the new flywheel fitted. Now for the test. Do we have spark? Indeed, we do and

a very healthy one, too, and on both cylinders! I had to hear it run, so with only the powerhead clamped to my work bench I put some gas in the tank and went through the starting ritual. It started on the first pull!! It sounded so beautiful that I decided right then that this motor had quite a character about it and that if it had a brain it would have let me know in some way that it was happy to have been rescued out of the hands of the junk dealer.

From here on the restoration was pretty much of a routine nature. There were many hours spent gunking and scrubbing inside and out. The gas tank, starter rope pulley, lower unit and propeller were sanded with wet sandpaper to eliminate the pits and then polished on the buffing wheel. The power head parts were wire brushed and then painted with the original dull aluminum paint.

I was almost certain that I would not be able to find another drive shaft housing, so I set about to find a way to repair this one. As it turned out, I now know one of the best welders this side of the Rockies. He silver soldered this broken bronze casting with heliarc and this casting can't be told from an original unless you had designed it yourself!! I then took the entire drive shaft housing, with casting permanently attached, to my favorite plating shop and had it chrome plated.

With all the parts now refinished the job of careful assembly took place. Few details were overlooked and finally on a Sunday morning a garbage can appeared in our driveway (since replaced with a test barrel) and was being filled with water. Several minutes later the test would begin. The only question in my mind was, would it pump water? The pump had checked OK and all the lines and water jackets were clean and there was really no reason to doubt that it would. The Johnson started right away and a few seconds later water came squirting out of the tube just as the book says. I was as happy as, I'm sure, any Antique Outboarder is when his favorite motor performs perfectly the first time. Besides all this, my F-75 has two cylinders and twice the power of the old Johnson Model 100!

During this past summer this 1935 Johnson kept appearing at Bass Lake, California on several occasions as it was the only running outboard we had at the time in California, new or old, and to the amazement of many, performed as well as many new motors. Curiosity at our campsite caused several other campers to get a ride in our boat especially after one morning at 6 o'clock when the little opposed twin began to sing its tune on the way to the fishing grounds. After their rides they admitted that it wasn't really that loud!

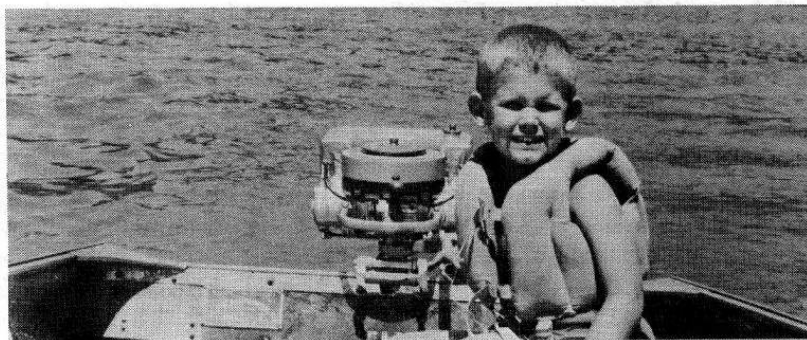

Notes from the Curator

R. A. Hawie

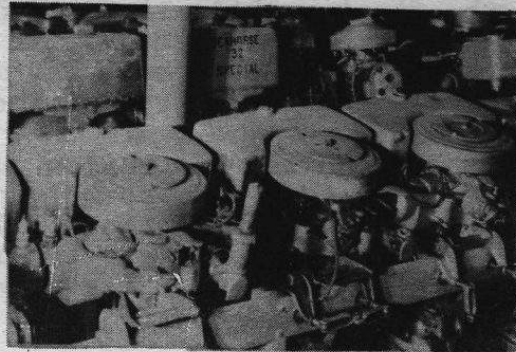

Well, after a side trip to matters literary in my last column, we will return to my basic theme of identification of motors.

Bendix Aviation Corp. produced outboard motors from 1936 through 1939. The motors were made by the Bendix Marine Products Co., South Bend, Indiana, a division of Bendix Aviation. The brand name was Eclipse, but I think that the name Bendix was used more often. The motors were air-cooled and shouldn't be confused with the Lauson motors which were also air-cooled but were 4 cycle motors. Because Bendix didn't make a large variety, we can cover most of the Bendix models. The models were SB, SM, SMD, and TMD -- standing for Single Battery, Single Magneto, Single Magneto Deluxe, and Twin Magneto Deluxe. The motors had a bore of 2 1/16, stroke of 1 1/2 inches, and the Single was rated 2 1/4 HP at 3300 RPM, while the Twin was rated 4 1/2 HP at 4000 RPM. Long shaft models were also available, and they had an L added to the model designation. I think that this is the only "universal truth" in outboarding -- if the motor is a long shaft model, go to L in the model designation.

The Bendix motors are rare as far as I can determine. I have only one Single Magneto model in my collection. When you consider that I have three Waterman motors over 50 years old, you can realize that the 30-year-old Bendix is rather rare. Of course, a collection reflects one's personal taste as well as the relative rarity of the various motors; but for several years I have kept a record of all motors offered to me, and Bendix is one of the rare ones. If you check the motors for sale columns of our newsletter, you will find that Bendix is also rarely seen. For instance, the Clarke Trollers, which are also of the late thirties, are in much greater abundance.

One possible explanation for the scarcity of Bendix motors is that their air-cooled feature caused them to be bought by salt-water men; and the ravages of salt water made junk out of them in short order, despite the fact that they had no water-cooling passages. Midwesterners who have not had much experience with salt water can not appreciate the destruction it causes. Even with the improved treatments given modern aluminum, it is possible for an experienced person to walk through a dealer's service area and spot the motors which have been used in salt water and which have been used in fresh water. Salt attacks the paint, the prop and the control cables; even the gasoline-oil mix smells differently if it stays in the tank for a few days! So I think that the big selling point of the Bendix motors, salt-water tolerance, probably is the reason why there aren't

many around today. Salt water, like insurance men, "will always get you in the end" as the old song goes.

Although the Bendix motors were not supposed to have been made after 1940, I have several service manuals for them copyrighted in 1946, from the Bendix Aviation Corp., Marine Division, Norwood, Mass., which is near Boston. I think that this was probably a parts depot as I have no information that whole motors were made after 1940.

The serial and model numbers are on a name plate on the clamp bracket. The name Bendix was cast into the rope sheave which sticks above the grill protecting one's fingers from the large multi-bladed cooling fan. If it seems that I am spending an unusual amount of time on a rare motor -- I am. The Bendix was a very modern-looking motor, more so than some of its contemporaries, and it's possible for it to be mistaken for a much newer motor; perhaps some members may have missed one, not realizing it was old.

"Bantamweight"
DINGHY POWER

Plenty Big Enough! Plenty Light Enough!

"Flyweight" outboards don't do so well in a tideway, do they? Eclipse, with ample power and no water-jacket weight, is a real yachtsman's outboard! Famous 15,000-volt ignition. Stromberg float-feed carburetion. Full tilt-up. Auto helmsman effect. No-fume air cooling. No water pump worry.

2½ H. P. Single Weight 27 lbs. Runs 1½ hours on a filling. \$79.50 at Brooklyn	4½ H. P. Twin Weight 41 lbs. Runs 1 hour on a filling. \$129.50 at Brooklyn
---	--

Silent Electric Model
the perfect trolling motor. **\$34.50** at Brooklyn

**The New, Air-Cooled
ECLIPSE
OUTBOARDS**



"My fan" may recall in covering Lockwood-Ash, I mentioned the Motorgo made by Lockwood-Ash and marketed by Sears Roebuck. Sears sold Waterwitch brand motors from 1936 through 1945. In 1946 and later the brand they sold was Elgin. Because of the wide distribution afforded any Sears Roebuck merchandise, the Waterwitch motors are in much greater supply than Bendix.

Before A.O.M.C. when I was a lone, isolated, insulated collector, I never paid much attention to Waterwitch. I still don't have one in my collection. It becomes a matter of time and effort. When you can trip over half a dozen Waterwitches in any marine dealer's service area, why bother to pick one up? The time and effort may be better spent trying to find a Johnson XR or a Hartford Sturditwin! Someday I know I'll be sorry I didn't bend down and pick up one of those Waterwitches, but such is human nature.

Digressing a moment -- the Hartford Sturditwin, a 1928 motor, has to be one of the rarest of motors. If any of our 300 odd (my faithful typist-wife will probably underline that word odd) members has or knows of a Hartford still in existence, I'd appreciate it if they would let me know for my own interest and edification.

We aren't going to return to Waterwitch for too long though. There are enough models so that the next page would look like a phone book if I tried to cover them all. Saves Dave's blue pencil if I don't try. One note though -- all models started with the numbers 571.--; the fourth and fifth numbers are the model number. I guess that 571 told Sears that you were interested in an outboard motor not a toilet seat, if you ordered from their catalog. So if you want a Waterwitch identified, make sure you send along the fourth and fifth digits. I have gotten letters with the model given as 571.

Waterwitch motors were not listed in the boating magazines (although I do have other lists of them), so that pictures and descriptions of the various models are hard to find. I don't profess to be a specialist in Waterwitches, but I know that many of the models had twin torpedo-like gas tanks joined by a flying wing. Truthfully they looked like they fell out of a Buck Rogers' comic book. I don't know who made the motors for Sears, and when I read Jim Webb's book, I may be embarrassed to find out.

Actually the Waterwitch motors are all antiques according to our definition, are relatively abundant and usually very cheap -- all good features for most collectors. If nothing else, your 11-year old can always wear the gas tank as a space helmet while watching the Saturday morning kiddie shows on the boob tube; and that ought to amortize the cost of the Waterwitch if you have priced toys this Christmas season.

The thought has occurred that perhaps an indoor meeting in early spring before boating season might be useful. If things work out, we will contact members within reasonable distance directly. This is being written early in December as I have been busy since boating season building a room to house my workshop so that I'll have room in the cellar for the next 100 motors. Hopefully winter will bring an end to these extraneous matters; and I'll have more time for antique outboards.



Why Your Dealer Guarantees the Evinrude

EVERY Evinrude Detachable Rowboat Motor that is sold carries two guarantees—First, the guarantee of the Evinrude Motor Company, the largest producers of rowboat motors in the world—Second, the guarantee of your local hardware or sporting goods dealer, whom you know personally. Your dealer has selected the "Evinrude" to sell because it is the one motor that he cares to guarantee and recognizes as the standard in its field. Your dealer knows that there are more Evinrudes in use than all other rowboat motors combined.

He knows that it attaches to any rowboat in less than one minute, carries just like a satchel and will actually drive a rowboat more than eight miles an hour—a canoe nearly twelve. He also realizes that it has the following exclusive features, which cannot be procured on any similar device in the world:



Evinrude Built-in Reversible Magneto, which is not only waterproof but actually operates when completely submerged.

Evinrude Compensating Device which controls the tiller and takes the work out of steering—no tugging at the tiller.

Evinrude Maxim Silencer, that wonderful invention for eliminating the noise of operation, can only be procured on the "Evinrude."

Evinrude Shock Absorbing Device which absorbs vibration can only be used on the "Evinrude."

The Evinrude catalog will be sent free upon request, write for it today.



EVINRUDE MOTOR CO.
110 M Street, MILWAUKEE, WISCONSIN

MOTOR COMPARISON

A 1928 JOHNSON vs A 1957 JOHNSON

JOHN WARD

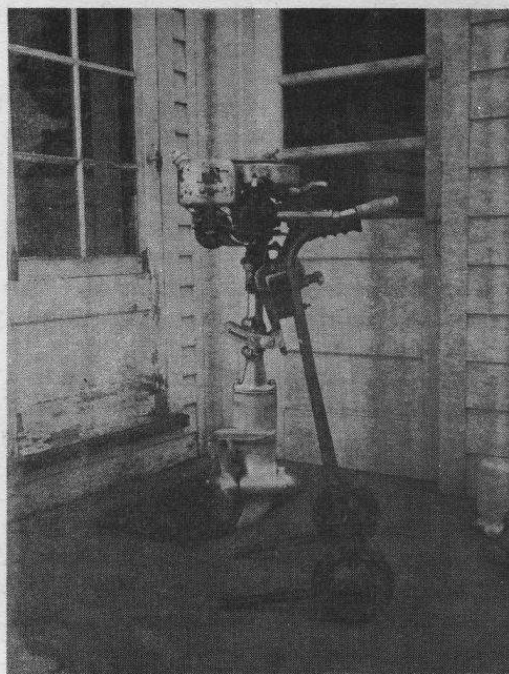

After reading several issues of *The Antique Outboarder*, I decided that I would try to do an outboard test. This was my first one; here's how it went.

The two motors I chose to test were a 1928 A-35 Johnson, at 2.5 horsepower, and a 1957 Johnson 3. I figured this would be a reasonable match because the '28 is surprisingly modern in spite of its age.

Both of the motors were in mint condition. The 1928 motor set me back about \$2.55 a year ago, and it was in running condition. (Antique motors are almost completely unwanted here, but when one is seen, it causes a stir and much reminiscing.) The '28 has a fairly large 3-bladed prop while the '57 has a small 2-bladed prop and an angled fishing (weedless) drive. Both of the motors have streamlined lower units, although the older one has a gearcase which protrudes in the front. Both of the motors have a 360-degree pivot reverse with a tilt lock.

As for cooling, the '28 has the water scoop behind the prop and a cooling system which operates on a vacuum principle. The '57 has the common impeller type pump.

The '28 has two opposed cylinders while the '57 is a modern twin cylinder motor. The '28 has a muffler directly beneath the gas tank while the other motor has an underwater exhaust. (This difference is not very noticeable when the motor is running.)

Both motors are mainly of aluminum and are extremely light. The ignition systems are almost identical. The carburetor on the '28 is completely unshielded, and has a large air intake scoop in the front and a float bowl mechanism that can be taken apart without tools. The throttle is between the carrying handle in the front and the spark control, which is under the flywheel. The newer motor has the usual, modern carburetor with a separate choke control.

The boat I used for this test was my 8-foot sea sled-hydroplane. Putting the motors on the boat was a cinch because they both are very light. Both have twin clamp screws. Operation is simple - to start the '28, you turn on the gas valve (which is located on the left side when you face it from the front), prime the carb, advance the timer lever to full, set the carburetor lever to choke position and pull on the starter cord. For the other, you do the same thing except that you do not need to prime it.

Since the compression on the 1928 was excellent, it started right up after I pulled the cord a few times. The 1957 started on the first pull, as is normal. The 2.5 did 7 mph at almost full throttle (2500 rpm or so) and the 3 did about $8\frac{1}{2}$. For trolling, the 1957 proved best, but the oldie was not bad at all. The vibration was about equal on both, but the 1957 does go about 1500 rpm more. I would take the 1928 for power anytime; I am positive that the 2.5 will outpull anyone's 3! It would be excellent for a sailboat auxiliary. Gas consumption was about equal.

In conclusion, I think these motors are about equal in most respects. The '28 has more power, is easy to operate and easier to repair. The '57 is a bit quieter and faster (it is 0.5 hp larger) and trolls better. The older one is an ideal auxiliary motor while the 1957 is the ideal fishing motor. Johnson Motors did exceptionally well with both and should be given a good pat on the back.

The following chart shows points of comparison for these two motors:

ITEM	1957 Johnson 3 hp	1928 Johnson 2.5 hp
Weight	37	41
Model	Jw-13	A-35
Top Speed	$8\frac{1}{2}$	7
Low Speed	Less than 1	$1\frac{1}{2}$
Reverse	pivot	pivot
Prop	2-blade, $6\frac{1}{8}$ X $6\frac{1}{2}$	3-blade, 6" diameter
Gas Tank	4.88 Pints	6 Pints
Bore & Stroke	$1\frac{9}{16}$ X $1\frac{3}{8}$	2 X $1\frac{1}{2}$
No. Cylinders	2	2
Horsepower	3 at 4000 rpm	2.5 at 2600 rpm

Anthea In Outboardland

A.T. Aitken



The AMOC is indeed fortunate to have many interesting people on the membership roles. It has been our pleasure and great fun to read the mail from many who write in. Most are greatly relieved to find they are not alone in the old motors scavenger hunt. Correspondance with Charles A. Parsons, who calls himself "Ye Olde Outboard Motor Collector, (Canadian Branch)" proved so delightful, we are spotlighting him, his humor and wisdom as our Personage at the Pier.

Mr. Parsons lives at 57 Gordon Street, Brantford Onterio, Canada. Anyone living near him will do well to drop by and have a chat. You will be in for a treat. His collection was started when he found an old Johnson OA-55 in a second hand store. He paid \$5.00 for his treasure and hurried home braving his way past his wife and her thoughts on whether his gray matter had left his skull. There in the safety and santity of his workshop he began the labor of love to restore it. His determination to restore this "Grimy Old Blister" to its original condition was accomplished in three months, rewarding him by starting on the third pull of the starter rope. Repairs consisted of welding, remanufacturing the one con rod, rebuilding the all metal cam and plunger water pump, cutting a complete set of gaskets, polishing all metal castings (aluminum), repainting in original, installing new decals on the gas tank and replacing a double ball race bearing on the lower end. After this session with what fast became an old friend, Mr. Parsons decided that "old outboards never die, they just lose their starter ropes and need someone to clean them up and love them." Mr. Parsons claims he fools his wife into thinking he is just going for a walk, but in reality he is running down leads of "another old putt-putt badly in need of a place to hide from the junk man." He is also lucky in that he can take his hobby to work with him. Work is with the City of Brantford Water Polution Control Plant (sewage treatment plant to the uniniated). One night as he was operating the sludge filtering end of things and in between keeping the sludge flowing in the right direction and not pouring out the doors, he set up his Champion 'Kingfisher' in a 45 gallon drum and proceeded to try to get it perking again after a 10 year rest. Problems arose, the old manual was well worn and grease stained at vital points, and the best he could get was a few short bursts and soon had a bad case of 'Outboard Arm'. About this time the foreman walked in..and walked out. The combination of the roar of an old outbaord and the clouds of exhaust smoke mingling with the aroma of filtering sludge is a new one in any one's book. With no success that night, he overcame the urge to heave it onto the sludge pile, and set it aside for a project for his son next summer.

The younger Parsons shares to some extent his father's enthusiasm for old motors. His first experience came several years ago when Mr. Parsons fired up the old Johnson OA-55. A crowd of curious people stood around making the usual comments we are all so familiar with, when the old warrior started up on the second pull of the rope. Grinning like the proverbial Cheshire cat he aimed the boat up river. He decided that as everything was going so well he would turn it over to the Rear Admiral, his son. The first thing the young boy did after taking command was to call for increased speed. He advanced the throttle to full ahead and the motor promptly exploded in a cloud of blue smoke and quit cold. After fanning the smoke away, he could not find his son. A hasty and worried look around discovered him in the bow of the boat, the fastest trip on record. It took quite a bit of persuasion to get him near the motor again. The laughter of the people on the pier soon died away when he quickly recovered the situation and got the motor performing perfectly again.

A winter project for Mr. Parsons is converting a room in his basement for a combination museum and workshop for his growing collection. He says there is a scarcity of old and really off beat motors in his part of the country, probably because most of the early motors were manufactured in the states and didn't get their way north to Canada as regularly. There is a large collection at Currey Bulmer Marine in Toronto for anyone up around that area that is interested.

Mr. Parsons signs off with a delightful wish for all members.. "May your starter rope never fly up and knock your hat off." And may we add, Mr. Parsons, may your typewriter never wear out. We want to hear more from you and all of our other friends telling us of their adventures in Outboard Land.

.....

New Members:

These people have joined the club since the last Antique Outboarder was published and membership now stands at 275. If you live near these new members, phone them or write them - in some way get in touch. Go to see their collection or extend an invitation to see yours. We all have to get acquainted, and besides it will be a lot of fun to talk antique outboards, exchange information, and ideas. Get in touch right away.

David Anderson, 2942 Seaview Avenue, Ventura, California
Robert C. Cook, USS Mt. McKinley (AGC-7) FPO, San Francisco, California
Dr. Lloyd C. Craver, R. R. 2, Box 350B, Andover, New Jersey 07821
Fuzzys' Motor Service, 717 3rd Avenue E, Alexandria, Minnesota
Charles E. Heath, 413½ West Diamond Street, Butler, Pennsylvania
Jim Johnson, 5611 Western Avenue, Omaha, Nebraska 68132
Edward Kowalczyk, Pearl St. Road, Batavia, New York 14020
Morris Marine, Inc., 1546 Florence Blvd., Florence, Alabama
Charles A. Parsons, 57 Gordon Street, Brantford, Ontario, Canada
Leonard W. Seeley, 706-B Nimitz, China Lake, California 93555
Tom Wenrich, RFD 1, Box 128, Disputanta, Virginia 23842
Theodore M. West, 1424 East Broadmoor, Springfield, Missouri

From The Weidman Collection

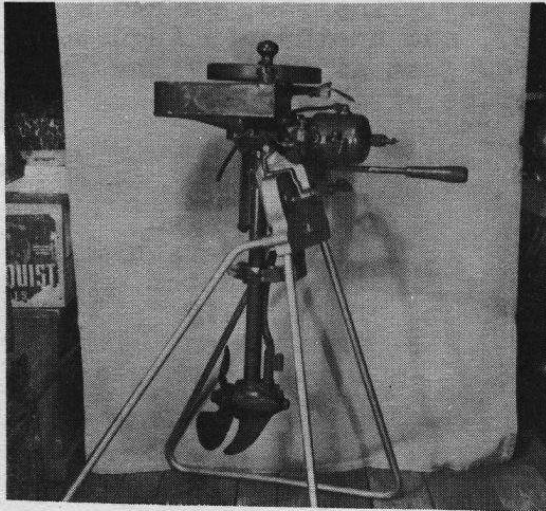

1920? EVINRUDE SINGLE,
with forward and reverse,
by turning tiller handle
the lower unit rotates 180
degrees to reverse and with
another turn completes the
180 degrees to forward.

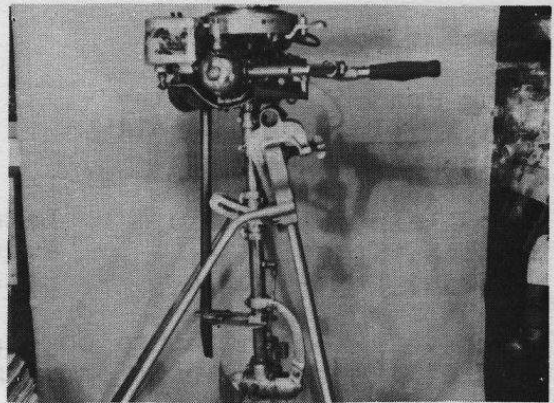

1924 JOHNSON WATER BUG.
Someone modified the exhaust
to place the fumes underwater
thereby losing the 360 degree
complete turn feature.

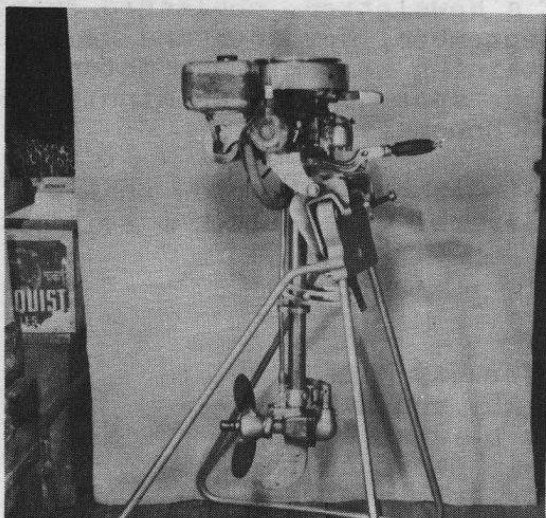

1920? CAILLE PENNANT 5 SPEED TWIN.
Runs on either magneto or battery
ignition. Has two speeds forward,
neutral and two speeds in reverse.
Selected by moving tiller handle up
and down through five notches.

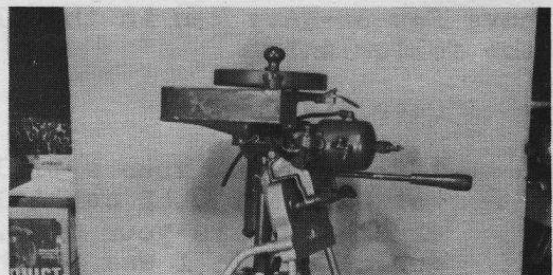

Early EVINRUDE SINGLE, exact
year not known as I am unable
to locate any numbers on it.
Can anyone help? Battery
ignition and can be run in
either forward or reverse
direction.

the editor's CORNER

d r reinhartsen

In the first issue of this magazine I made the comment that we wouldn't have any meets for a few years because our membership is so scattered. It didn't work out that way. Instead, we had a meet in August, 1966, two in June, 1967, and another in August of 1967. The number of meets seems to grow just as fast as the Club! In 1968 there will be a meet in every part of the country.

<u>PLACE</u>	<u>TIME</u>	<u>CONTACT</u>
Long Branch, New Jersey		Marcus Wright
Los Angeles, California		Dick Anderson
Bladensburg, Maryland		Bob Thornton
Seattle, Washington		Bill Kelly
Eau Claire, Wisconsin	Late Summer	Chris Owen
Dallas, Texas	August 24, 1968	David Reinhartsen
Easton, Connecticut	Late spring	Dick Hawie

We have a list of hints on organizing a meet prepared. If you would like to organize one, ask for a copy. If you would like to help one of the people above, please get in touch with them. They would appreciate your help.

We all hate to admit it, but this club has faults. One of them is lack of communication between members. For the most part, correction of this fault is up to you. Get in touch with nearby members, go to meets and write to people who have a motor similar to yours or a similar problem. When you go to a strange city, take the membership list along--call members and meet them. We of your staff feel that our publication quantity and schedule should be changed to permit publication of a Newsletter, published every February, March, May June, August September, November and December. This will be a one page letter, containing member news, motors and parts wanted, ads and other on the spot, up to the minute news. Bob Zipps and Bill Kelly will do the honors.

I once commented to a reporter in a telephone interview that we have few ex-Navy men in the Club. Several weeks later I received the following:

"Dear Sir:

After reading your article in Weekday Magazine, Vol. 13, No. 8, I can tell you why you have no ex-Navy men in your club. It's because during World War II, I was in the repair party on three different ships, and even during drills we had difficulty starting the handy billies."

Sincerely,

"P. S. I'll stick to oars!"

Watersport Magazine, the official publication of the Boat Owners Council of America, has accepted an article about the club for publication in its December issue. Ward Kennedy of Argosy Magazine has promised that his picture story of the 1967 New Jersey Meet will appear in the March or April, 1968 issue. The December, 1967 issue of Rudder has an article on Antique Outboards.

Between September of 1964 and April of 1965, Outboard Historian Jim Webb devoted full time to researching material for his book. Considerable time and expense went into preparation of the manuscript for his book. Finally, it is in print and available from Renaissance Editions, Inc., 527 Madison Avenue, New York, New York, 10022. Better get a copy to settle any arguments when you attend next year's meets.

Also, Jim Webb has correctly pointed out that Waterman was not the first outboard device, but rather a "Screw Propeller" patented by a T. Reece on October 23, 1866. The 1866 has been noted on our emblem, but the Waterman seems a bit innaccurate. Therefore, look for a gradual change of the emblem during the coming year. As Jim Says:

"In the patent title, Reece refers to his device as 'Improved Portable Propeller and Steerer for Boats.' In the description he says in part: 'The object of this invention is to provide small vessels - such as whale boats, yawls, jolly boats, skiffs and the like, usually propelled by oars and small sails - with a propelling apparatus to be operated by man power, that may be attached or detached from its position as may be required.'

Clearly, this is an outboard motor device though handpowered. Substitute 'motor power' for an 'Power' in the patent statement and you have a good definition of an outboard motor. Also, the vertical drive shaft, horizontal propeller shaft, bevel gears and stern bracket are mightly close to the standard design of today.

I found no record that this was ever produced or offered for sale. They didn't advertise much then, and ads are about the only lasting evidence of public offering. However, the patent description proves Reece had put a lot of thought on the idea. He proved people were thinking about how to get a boat from here to there without the hard work of rowing or poling. This was an old problem. The first outboard device to be publicly run was of French origin and appeared in 1881. The first American made outboard device showed up in 1895. Anyway, we are not trying to show anything but the first idea in our emblem, if I am to judge from the 1866 date. If you don't use Reece, the father of the idea, then what will you use? The first outboards here and abroad were electric. Gasoline did not appear until 1896."

Two new Spark Plugs have joined the club. Bill Kelly of Seattle, Washington is organizing not only a Seattle Chapter, but a meet in that area. Jim Johnson, as friend (and competitor) of Bud Cowdery, has also joined and promises to contribute a much-needed article on propellers. Jim lives in Omaha, Nebraska.

TRADER'S COVE

R.H. ZIPPS

As of the July 1967 Issue, a major step forward was taken by Trader's Cove your classified section. With that issue non-members were and are now required to pay for classified ads. This was put into practice to help offset the printing and mailing costs and to require the advertiser to show good faith by paying for his ad. The cost which is a service charge, is \$1.00 per motor. The amount was given considerable thought since, I did not want to make the fee high enough to discourage advertising.

There is absolutely no fee to members for advertising in any of the various categories, and furthermore members are encouraged to use this column. The requirement of the fee to non-members will even further the benefits to members by ensuring that he gets as much return as possible for his club dues.

Non-members are required to complete the Form 101 which has been revised to require an even more detailed description. There is a space on the form for a "price". As a result some of the ads in this issue contain extremely high prices. I would not hesitate to write to these and make them an offer more in line with the normal costs. The remainder of those ads without price wanted a best offer.

Please forward all requests for ads directly to me, at
24A St. Regis Street, East Hartford, Connecticut 06108

Another area where Club Members may obtain help is from Marcus Wright, the Club Parts Acquisition Officer. Anyone needing help in locating parts for any motor should contact Marcus first. Between his crystal ball and his ouija board Marcus can make parts come from nowhere. I once heard a story of the time that Marcus located a powerhead for an Elto Quad in the middle of the Mojave Desert using a divining rod but I didn't have time to verify it. Do not send parts wanted to me, send them to Marcus and he in turn sends them to me. Marcus really has his hands full in his duties and my hat goes off to him.

More on parts, - parts cost an arm and a leg when bought individually or in relatively small groups. If you are looking for parts or have a favorite motor through whose consistent use will eventually require parts, I would suggest buying a complete duplicate motor. Think about it, why pay five dollars for a cylinder when you can buy the entire motor for fifteen or twenty dollars. Scan through this issue and back issues and see if you find a duplicate. With the growth of our Club, spare parts will become more and more scarce and Marcus' job will become tougher and tougher, and eventually all spare parts will have to be cannibalized as is the case right now for many models. While prices are low for complete motors beat the rush and get yourself a duplicate. Think About It.

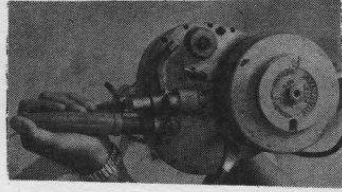
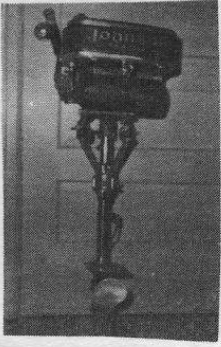

**GENERAL REQUIREMENTS
FOR**

CLASSIFIED ADVERTISING

1. a) Members-Complete AOMC Form 101 or include: Make, year, model, serial, number of cyl, runs or not, condition of compression and spark, list parts missing, give overall condition, features, price, state if member.

b) Non-members-must complete AOMC Form 101. Forms can be easily obtained by contacting this writer.

2. Advertising rates: Members--Free, Non-Members--\$1.00 per motor advertised.

3. Closing Dates: All ads must be received not later than the 1st of the month preceding the date of issue. Issues are mailed on the 1st of January, April, July, and October.

4. Transactions Based On Good Faith: Deliberate misrepresentation or violation of the code of business ethics and good sportsmanship will constitute grounds for refusal of advertising and disbarment from AOMC.

5. Warning to Purchasers: The AOMC will accept no responsibility for any unsatisfactory transaction involving articles which either have or have not been described per paragraph 1.

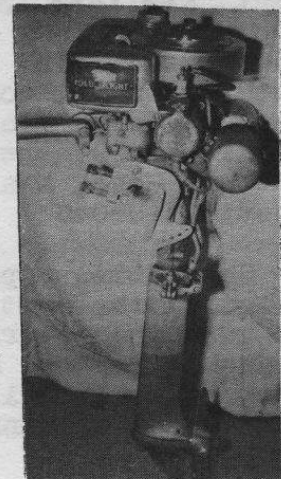
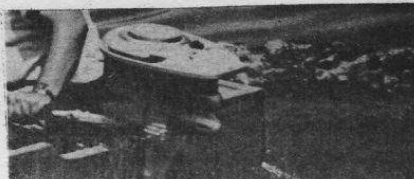
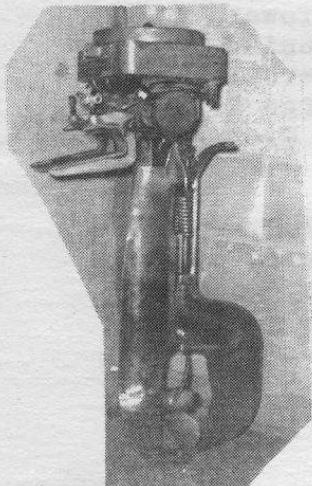
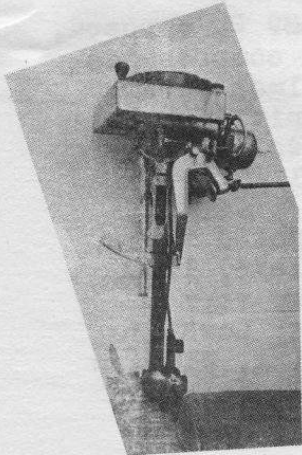
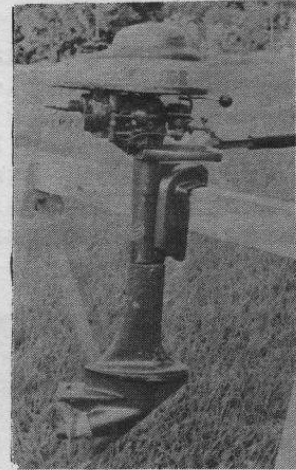

MOTORS FOR SALE

CAILLE- Liberty Twin, opposed, does not run, complete, good compression and spark, cracked cylinder, American Bosh Magneto, SEE PHOTO BELOW, Stanley J. Travinski, 33209 Oakland St. Farmington, Michigan 48024

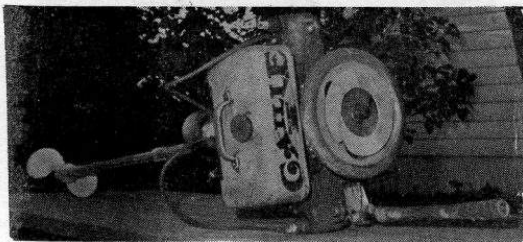

CAILLE- Mod 12, Ser C12501, Twin, opposed, runs, complete, good, condition, from description given this motor has a variable pitch prop. Roy K. Smith, Route 2, Box 105, Sherwood, Oregon 97140 (For those interested in Cailles, the above two motors would be excellent examples of engineering extremes of one manufacturer)

ELTO- Mod A, Ser 8245, Opposed Twin, Complete, Operating cond unknown, has knuckle buster, good overall condition, \$25.00 Oscar Montonna, Broadway, Cape Vincent, New York 13618

Elto- Opposed Twin, 3 HP, 1922, Ser 2601 ?, runs, complete, has welded cylinder, good overall cond, Richard Gunther, 281 Hillstown, Road, Manchester, Connecticut 06040

ELTO- Ser 64616, opposed Twin, runs, complete, dent in gas tank, very good overall cond, has knuckle buster, Kenneth Napierkowski, 1283 11th Ave, Natrona Heights, Pennsylvania 15065

ELTO- Mod K, Ser 56913, opposed twin, good compression, complete, 1929, battery ignition, good over all cond, Thomas J. La Broke, Box 84, Fort Covington, New York 12937

ELTO- Mod 310, Ser 0389 P, opposed, twin, runs, very good compression, complete, no dents, almost new condition, battery ignition, Robert Bonnett, 1198 Walker, Blackfoot, Idaho 83221

ELTO- Ser 1623903, opposed twin, foldlight, runs, complete, 1930, small dent in gas tank, very good overall condition, Lower unit folds for carrying, \$100.00 L.W. Frailey Sr. , 5641 E. 22nd Street, Tucson, Arizona 85711

ELTO-Foldlight, opposed twin, does not run, complete, good overall condition, lower unit folds for carrying, Earl W. Kurtz, 228 Fairview Ave. Iowa City, Iowa 52240

ELTO-1936, single cyl, Ser 101786, runs, good appearing and good working order, best offer-will consider larger motor, Leo Mc Inerney, Box 325, Fairfield Montana 59436

EVINRUDE- Row Boat Motor, Mod A, Ser 99782, Single foward pointing cylinder, running cond unknown, good overall cond, brass lower unit, George R. Smith Route 5, South Haven, Michigan 49090

EVINRUDE- ROW BOAT MOTOR, Mod A Ser 101685, Single forward pointing cylinder, does not run, good compression, no spark, good over all condition, Frank Bishop 1529 East Worthington Ave. Charlotte, North Carolina 28203

MOTORS FOR SALE

EVINRUDE- Sportwin, Ser 7230N
Opposed Twin, runs, good comp,
complete, gas tank slightly
dented, fair overall condition,
Mr. N.E. Holmes, 2128 North 46th
Street, Milwaukee, Wisconsin
53208

EVINRUDE- Sportwin, Ser NS10655,
Opposed Twin, runs well, complete,
very good overall condition, \$100.
John P. Gerron, 149 Talcott Road
West Hartford, Connecticut, 06110

EVINRUDE- Sportwin, Good running
condition, complete, has dent
in gas tank, like new overall
cond, Stanton F. Randolph, 102
East 97th Street, Kansas City,
Missouri, 64114

EVINRUDE- 1932, Mod 409-410 Salt
Water, Ser 409063, Opposed Twin,
running cond unknown, complete,
bronze lower unit and prop, good
overall, cond. D.W. Behnken, Allen
Road, Norwalk, Connecticut 06851

EVINRUDE- Mod 4357, Ser 05418,
Opposed Twin, runs, complete,
good overall cond, 1 1/2 HP,
needs cleaning, Richard
Goldberg, Rm 1408, 16 Court St.
Brooklyn, New York

EVINRUDE- Mod 6039, Ser 01091,
Speeditwin, 22.5 HP, Opposed,
Twin, runs, complete, 1940,
hasn't been used since 1954,
\$75.00, Arthur Loigren, 3
Charles Street, Wellsboro
Pennsylvania 16901

JOHNSON- Waterbug, Mod A, Ser
8239, opposed twin, runs, complete
good overall cond, slight dents
in gas tank, \$235.00, William
T. Sasnett, 229 North Columbia,
Salina, Kansas 67401

JOHNSON- Mod AB, Ser 20840, Twin,
opposed, runs, complete, has not
run in two years, good overall
cond. \$75.00, Will Clarke, 504
Rhodes Drive, Route 3, Box 552,
De Land, Florida 32720, Tel.
904-734-9490

JOHNSON- Mod A-25, Ser 27935,
Opposed Twin, Good Comp, runs,
Complete, Small Dents in Tank,
Mrs. J.H. Barratt, 2025 Parkside
Dr., Apt E-1, Des Plaines, Ill.

JOHNSON- Mod K-50, Ser 144297,
8.0 HP, 1930-32, Alternate Twin,
runs, complete, very good overall
cond, Robert Coke, Box 887,
Clarksville, Tennessee 37040
\$75.00 Tel 647-3334

JOHNSON- large alternate Twin ,
Mod SD-20, Ser ?, 16.0 HP. 1949-50,
runs for short time stalls & over
heats, gas tank missing (mile-
master Tank), fair cond, \$50.00, F.
Perruccio, 919 Franklin, Hartford,
Connecticut 06114

JOHNSON- Mod LT-37, Ser 266282,
Runs, complete, alternate twin,
small dents in tank. hole in tank
repaired, fair overall cond, R.O.
Smith, 718 Ojai, Sun City Center,
Florida 33570, \$75.00

Mercury- Mod KF-5, Ser 432925,
1949-52, runs, complete, brand
new motor in original carton, never
used, \$245.00, Floyd Johnson, P.O.
box 404, 11821 107th Ave., Sun
City, Arizona 85351

Waterwitch-Mod MB, Ser 3744, runs,
Single, complete, very good over
all cond, started on first pull
when used last, Raymond Evans,
388 Old Main Street, Rocky Hill,
Connecticut 06067

PARTS WANTED

EVINRUDE- 1920, Mod A, needs cylinder, clamp pads, Elto-Senior Speedster-1930, Atwater Kent Ignition Complete, Bill Kelly, 10201 114th Place NE, Kirkland, Washington 98033

LOCKWOOD- Powerhead parts for Chief. David Reinhartsen, 1107 Pueblo Drive, Richardson, Texas

Misc- Ray Machen has started a spark plug collection. Let's all help him out by sending him the old plugs that you have replaced. Ray Machen, 624 Gardner Road, Westchester, Illinois

EVINRUDE- Mod 4407 Ranger, needs ignition coil. Johnson- Mod Ms-38, needs ignition coil. Philip Graen, 901 East Jefferson St. Bloomington, Illinois 61701

EVINRUDE- Mod A, needs cylinder, and exhaust manifold, Elmer Coyte, 1001 Lasswade Drive, Tallahassee, Florida 32303

EVINRUDE- 1928, 12 HP, Fastwin, needs Starboard Cylinder.
EVINRUDE- Mod 6039, Speeditwin, Needs handle assembly, carb cover. JOHNSON- Mod KA-37 needs crankshaft, crankcase, connecting rods and steering handle.
JOHNSON- Mod A-25, needs crankshaft and crankcase. Marvin Howell, 906 Winthrop, Joliet Illinois 60435

JOHNSON- Mod XR-55, needs misc powerhead parts. John Toprahanian, 2618 Landis, San Diego, California

KOBAN- needs carburetor and crankshaft. Robert H. Zipps, 24A St. Regis Street, East Hartford, Connecticut 06108

CAILLE- Liberty Twin parts. Bill Hayes, PO Box 97, Clearlake Park, California 95424

MOTORS WANTED

JOHNSON- V-45 thru V-70, S-45 thru S-70, LOCKWOOD- Chief Mod 82B, 92B, 160, CAILLE- Mod 42, 48, 249, MUNCIE- Mod OB-15, OB 16, ELTO- Cub or Pal, Quad, Super C, EVINRUDE- Big Four, Speeditwin Mod U, 143, 156, Mate or Scout. Bill Kelly, 10201 114th Place, NE; Kirkland, Washington Bill is a serious collector and will consider all reasonably priced motors, listed.

CLARKE- Troller, Bill Hayes, PO Box 97, Clearlake Park, Calif.

KOBAN- any model, any year, any condition. Robert H. Zipps, 24 A St. Regis Street, East Hartford, Connecticut 06108

CAILLE- Liberty Twin, (There is one in the motors for sale section) Bill Hayes, PO Box 97, Clearlake, California 95424

PARTS FOR SALE

JOHNSON- S-45 Crankshaft \$10.00
John Toprahanian, 2618 Landis San Diego, California, 92104

LITERATURE WANTED

EVINRUDE- Early Evinrude Service Manual. Bill Kelly, 10201 114th Place NE, Kirkland, Washington

MOTORS SEEN

EVINRUDE- 4203-03816, Pal. E.E. Coyte, 5436 2nd Ave. Pine Manor, Ft. Myers Florida 33901

ELTO- Mod 4266, Pal. Spike Wenhart 2581, Copley Road, Akron, Ohio 44321

BENDIX- Single, Air Cooled, John Johnson, 68 Harrison Ave. Red Bank, New Jersey

THE ANTIQUE OUTBOARD MOTOR CLUB
1107 PUEBLO RICHARDSON, TEXAS 75080

PRINTED IN U.S.A.

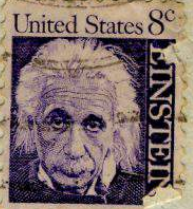

Walter L. Weidmann
c.o Weidmann's Outboard
Voorheesville
New York 12186 D'67

Printed Matter
No Commercial Value



A prominent northern Club member tests his
1928 Elto Speedster. It's cold in November!