

# Antique Outboard News

SOUTHERN CALIFORNIA CHAPTER

Volume 2 issue 5  
December 14 2006

## EXTRA! EXTRA! EXTRA!

### Big Christmas Party Dec. 2! Free Free Free Newport Harbor Nautical Museum

Special Christmas lunch  
Roasted turkey ,spiral ham  
Cranberry & green salad  
Sweet potatoes ,green bean  
With cream of mushroom  
Sause,,dinner rolls, corn  
bred & much more  
**ALL FREE!!!**

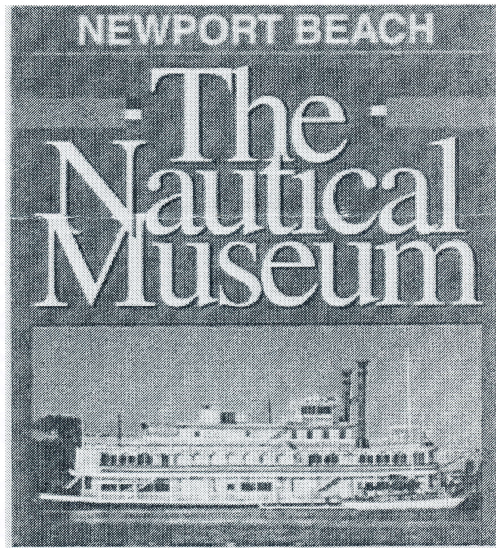

Great door prizes  
Bumble bee outboard  
Tools, die grinder, batt drill  
Manny other prizes  
Also free gifts for all.  
Lets have a great party it will be  
the last meet here. After jan. 1  
It will be gone, so lets all give a  
great farewell and thanks to  
Marshall Steele for being a won  
derful host. Thanks from all of u  
at A.O.M.C. Merry Christmas!

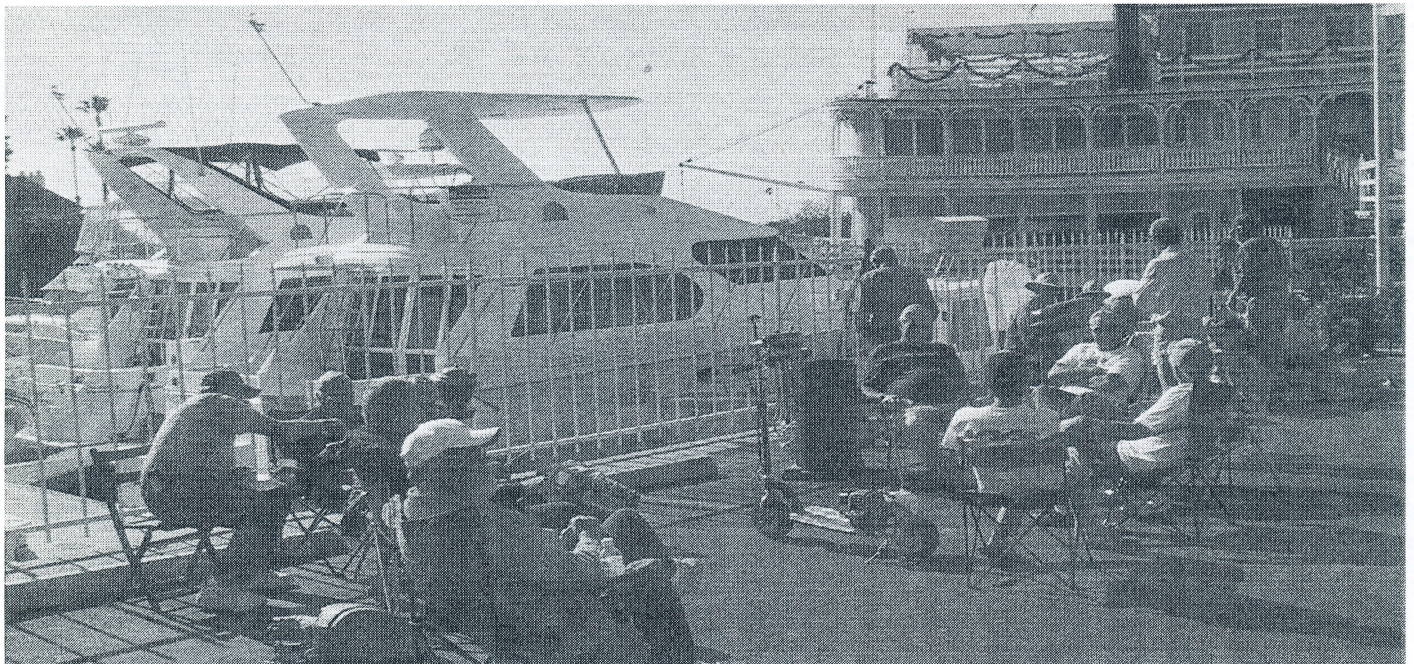

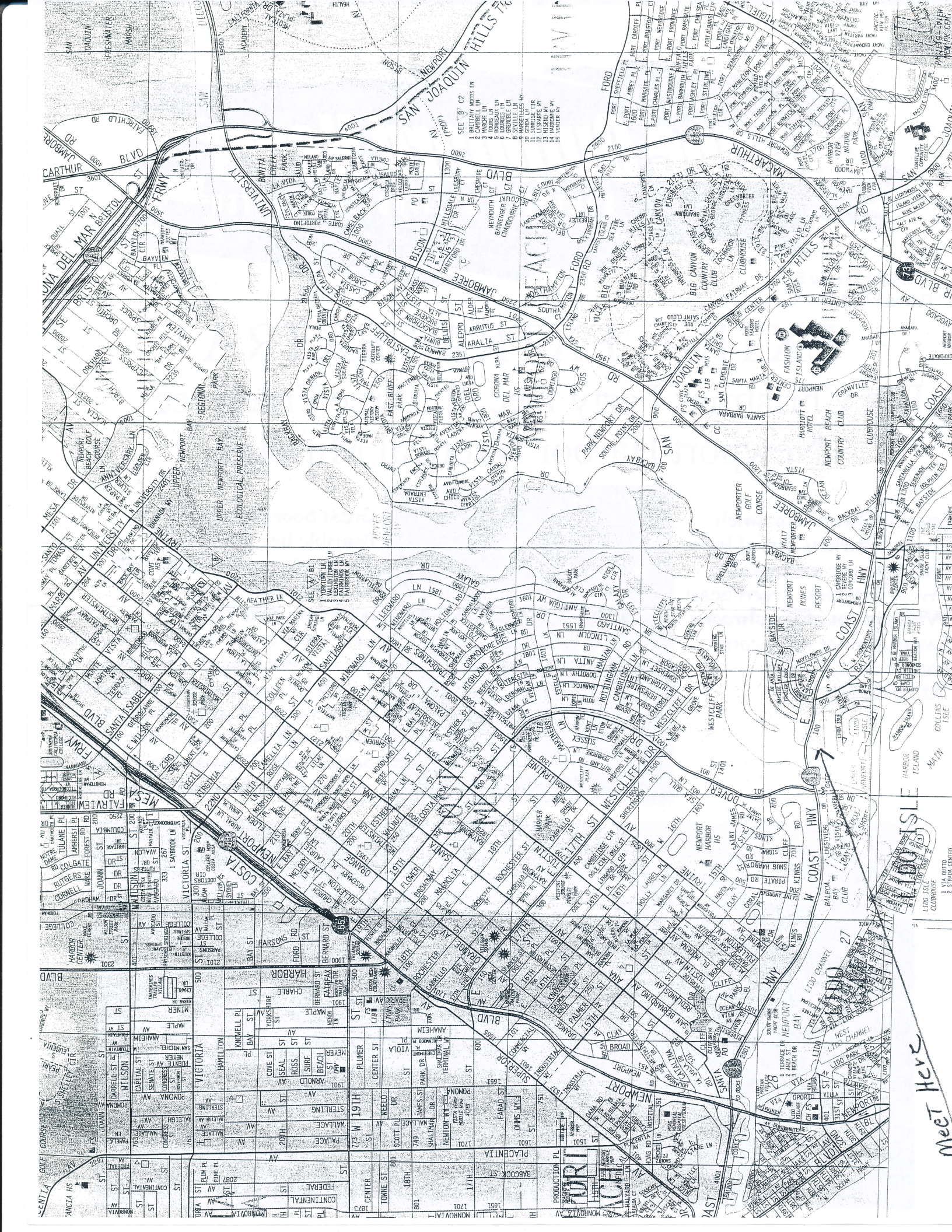

Meet Here

- SEE 'B' C 2
- 1 BENTLEY KNOLLS LN
  - 2 WADSWORTH LN
  - 3 TAYLOR LN
  - 4 TAYLOR LN
  - 5 BROADWAY LN
  - 6 BROADWAY LN
  - 7 BROADWAY LN
  - 8 BROADWAY LN
  - 9 BROADWAY LN
  - 10 BROADWAY LN
  - 11 BROADWAY LN
  - 12 BROADWAY LN
  - 13 BROADWAY LN
  - 14 BROADWAY LN
  - 15 BROADWAY LN

- SEE 'B' 1
- 1 VIKTORIA LN
  - 2 VALLEY FORE LN
  - 3 VALLEY FORE LN
  - 4 VALLEY FORE LN
  - 5 VALLEY FORE LN



## Executive editor Ron Hill

Remember, CHRISTMAS COMES BUT ONCE A YEAR, SO SEE YEA ALL IN NEWPORT,  
DECEMBER 2nd

### BIG STORIES BY RON HILL

Well, I've written a few thousand words with that same title... I guess BS might be an easier way to say it.

For those who MISSED the last meet... Well, it was your loss. Those that attended enjoyed the day, especially my brother, Russ and myself... Once I found where we were meeting, I called my brother, and he found it easy. I won't have any trouble next time, as I'll know where I'm going.

I'm having Ernie Dawe, of Dawe Craft Classic Racing Boats, build a Small hydro, so we can get more people on the water at "WET MEETS". My "PLAN" is to allow you to drive this boat with MY motor... Speed Trials with a GPS. Or you can run your motor on it, up to 15 HP.

I'm hoping to have Ernie at the December Meet in Newport. Ernie would be an asset to OUR CLUB.

If you didn't hear, Brad Menet, OUR BRAD, and Pete Michelmore from Hawaii, raced THE BLUE WATER RESORT AND CASINO 300 ENDURO in DIVISION I, they finished SECOND, won \$100 and a nice trophy. They drove a 16 foot Glastron that was the Gold Finger Boat... or Some James Bond film, boat number 007. Pete wore a batman helmet. 40 boats were in this CLASSIC ENDURO. I'm proud to say that my son won his class and was overall winner, his co-driver was Pat Bowman, many of you met Pat at the San Diego meet.

Our Brat Bar-B-Quer, Bill Schwab, is getting his daughter in to Classic Outboard Racing... Class A Hydro. Bill is working on a 4-60 Evinrude and I have purchased two Johnsons to start displaying at meets..

Ron Hill

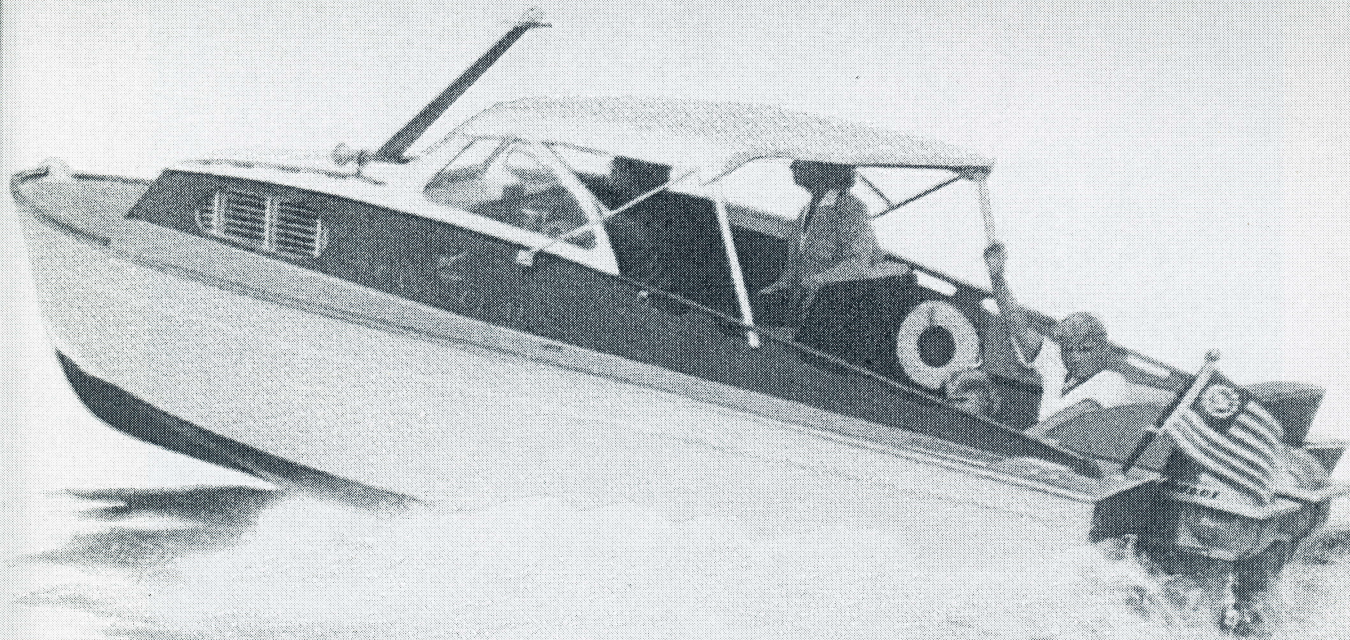

# *dreamship on a budget* ...million-dollar fun!

You've dreamed of the day! And now it's here... the wonderful day when you can skipper your own eat-aboard, sleep-aboard *live-aboard* cruiser... swift, able, comfortable! Your cruising range is America-wide. Roam the waters close to home, or trailer your craft to far-away shores. Cost-wise the news couldn't be better! From inexpensive kit boat to ready-to-go cruiser you can buy in various stages of construction to suit any budget.

For power, one choice—it's BIG TWIN, the motor that made outboard cruising not only practical, but tops in cruising fun! 25 eager horsepower for speeds to 20 miles on light cruisers—up to 30 miles with twin motors. And now with finger touch *electric starting* if you wish, with complete remote control at steering position for d—starter, choke, throttle, gearshift—finger tip handling ease!

**SEE YOUR EVINRUDE DEALER**—look for his name under "Outboard Motors" in the yellow pages of your phone book. For complete catalog and Evinrude "How-to" Book of Outboard Cruising, write EVINRUDE MOTORS, 4302 N. 27th Street, Milwaukee 16, Wis.

IN CANADA: Manufactured by Evinrude Motors, Peterborough.

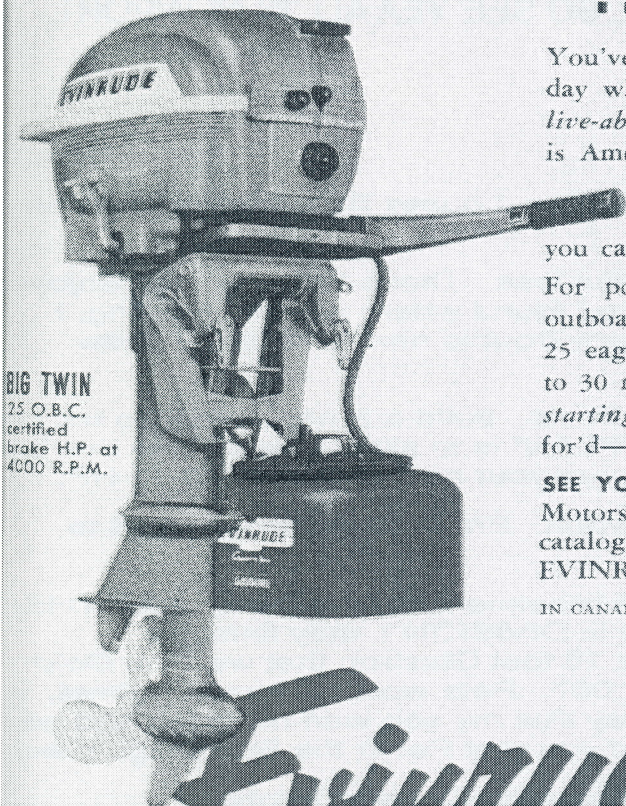

**BIG TWIN**  
25 O.B.C.  
certified  
brake H.P. at  
4000 R.P.M.

# *Evinrude*



*...free*

Write for full-color catalog of the complete Evinrude line, and copy of

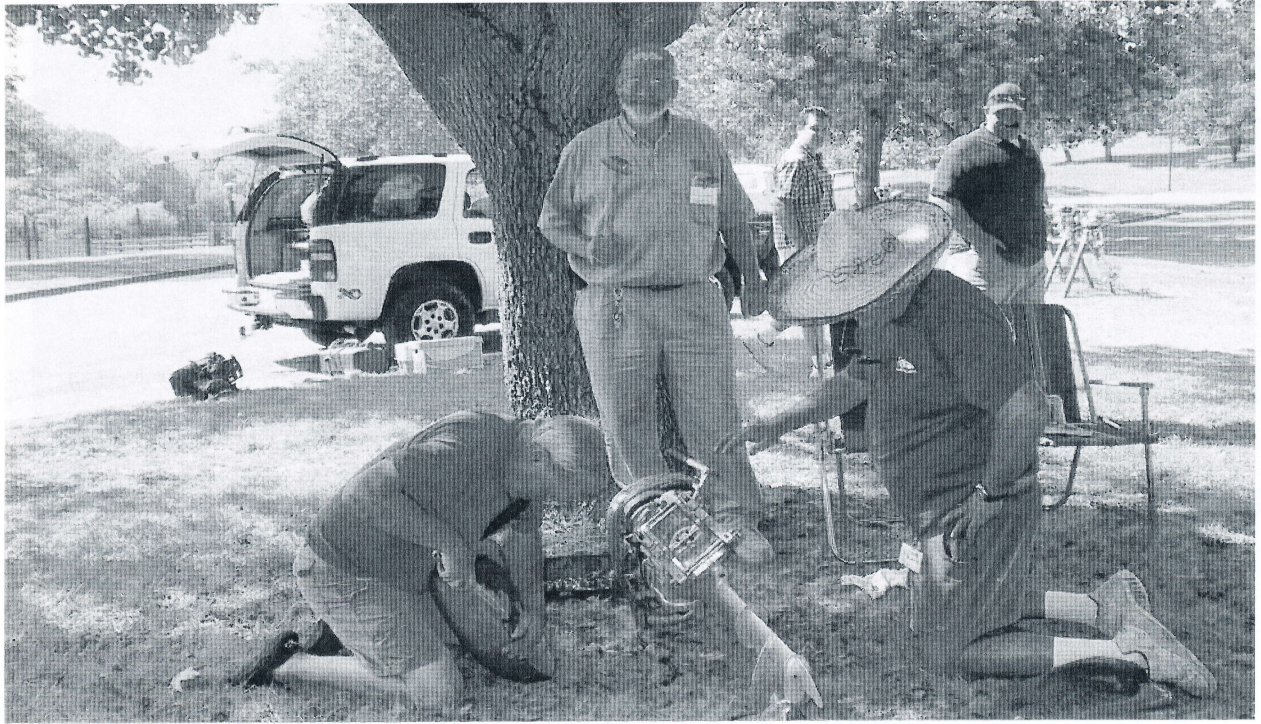

Gerry Coates makes some on the spot repairs to his restored Mercury outboard with the help of neighbor Dave Buuas. Craig Butcher stands by with a hammer in hand and ready to use it if necessary !



Al Jarvis and Paul Brinkman, Jr, display some of their restored antique outboard motors at the AOMC meet in October at Puddingstone Lake.



Members Russ and Ron Hill with President George Kent enjoy some of the memorabilia from the Hill brothers racing past. Ron manufactures and restores rare racing propellers at his facility in Santa Ana, California.



Our club President, George Kent, enjoying a fine day on Puddingstone Lake in his old aluminum boat powered by a restored Johnson 7 ½ h.p. outboard.

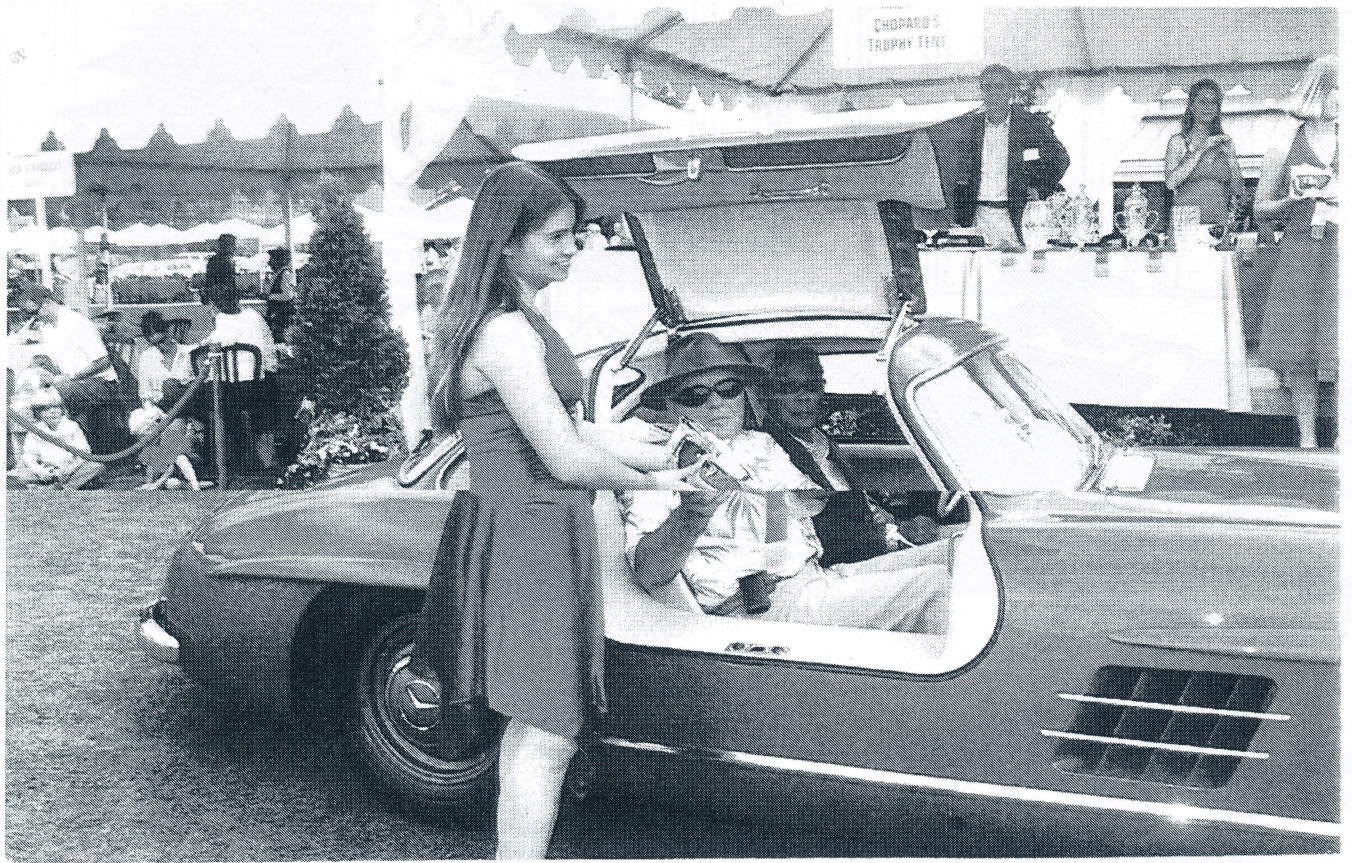

**Weston Hook receiving his trophy for Best of Show at the 2006 Newport Beach Concours. He also received a beautiful Chopard watch.**



**Southern California Chapter members Richard Plavetich and Paul Brinkman, Jr. enjoyed the Laguna Beach Concours last month. Pictured in front of a beautiful 1964 Porsche owned by Susan Plavetich are Richard, Susan, Paul and his wife, Marsha. Richard won first place for the second year in a row for his incredible Isetta 300. Congratulations!**



# Signaling Sailor

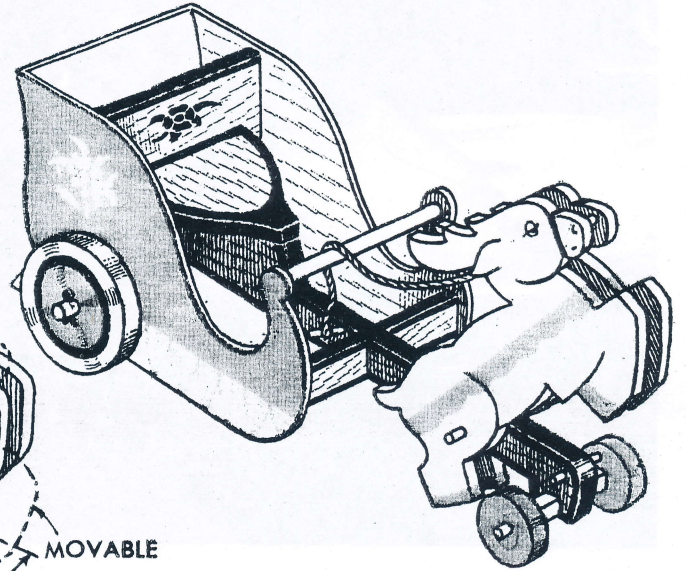
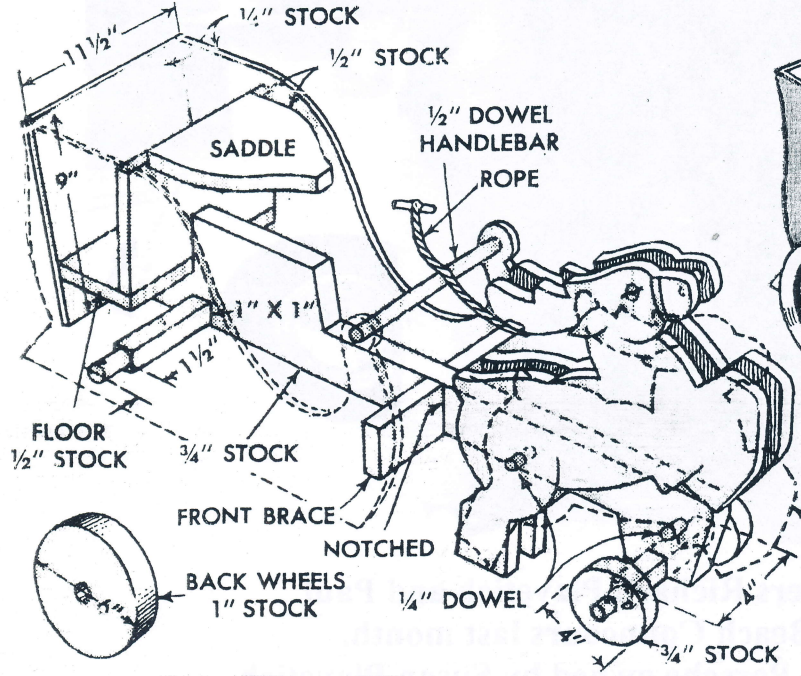
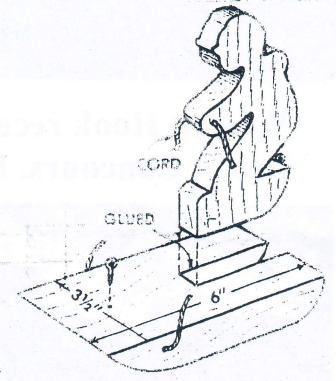
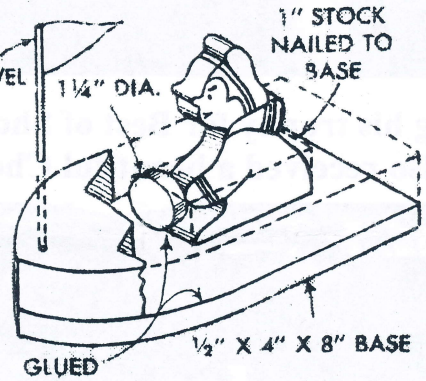
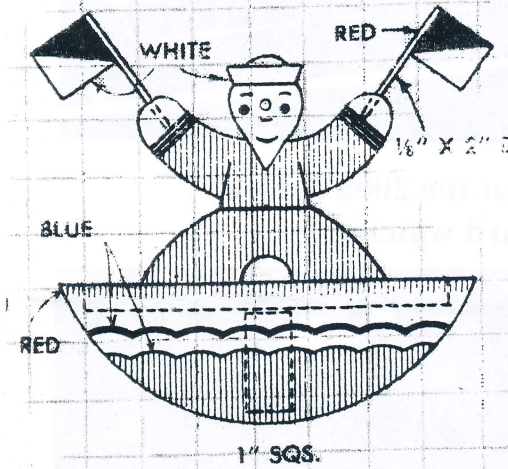

# Reindeer-Sleigh Cart

Remember when we made our own toys for our children? Here is what dad's made for their kids at Christmastime. Pictures from Popular Mechanics 1946. Have you made any toys lately?



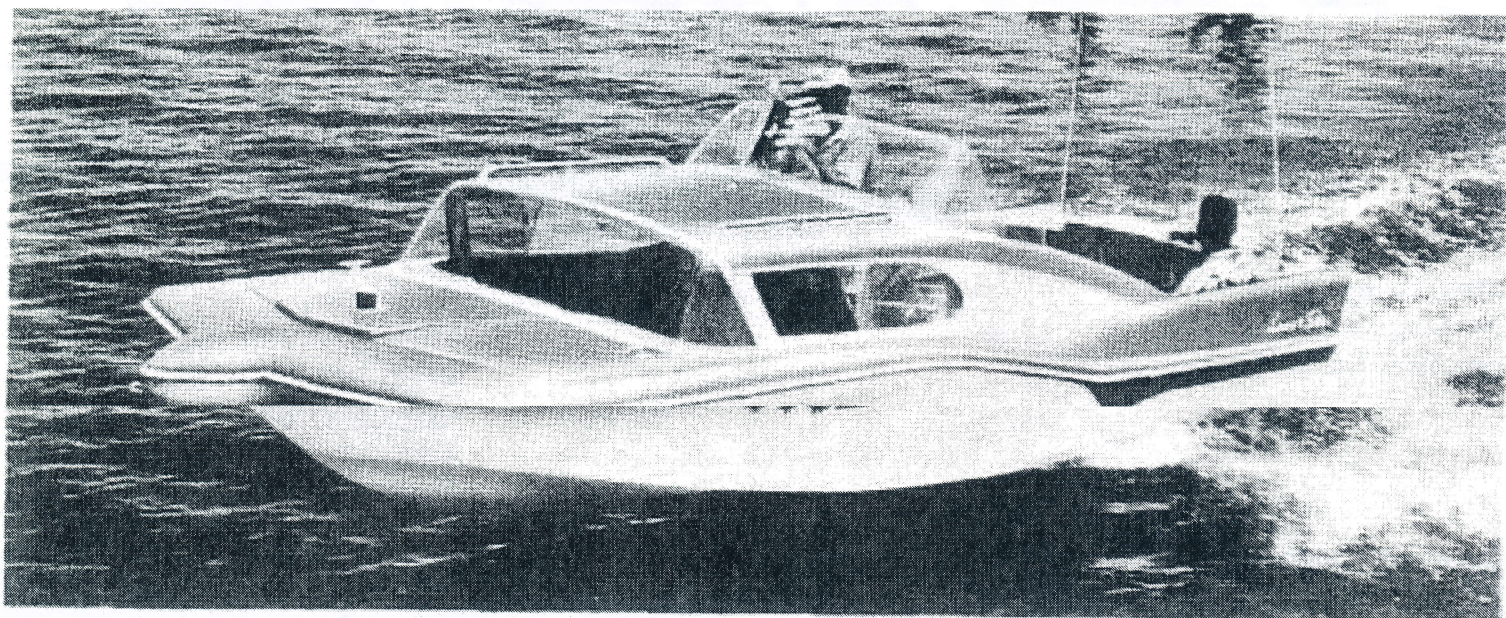

Fig. 4. An Outboard That Might Have Come Out of Our Future—Lone Star's 19-foot Fiberglass "Caribbean" with Plenty of Cruising Speed and Power For Towing Skiers  
(Courtesy Lone Star Boat Company)

Or you may be interested in a sport that is gaining in popularity day by day—outboard cruising. You will be seeing things from a new angle as you cruise strange new waters, finding exclusive and secluded beaches for picnics and swimming. You may want to take an overnight trip on your boat, or a trip that lasts several days, either camping out at night or sleeping on the boat itself.

All or any part of this is possible if you own your own boat. In comparison with other boats, the outboard motor boat and motor are inexpensive to buy, can be readily hauled about, do not cost too much to repair, and can usually be stored in your own garage. If you cannot afford a new boat and motor, good used ones are available that will enable you to enjoy many of the yachtsman's pleasures without the expense that goes with owning a yacht.

However, a great deal of your pleasure depends on selecting the right combination of boat and motor for the particular sport in which you are interested. Before you become an old hand at running your outboard motorboat you will also want to have basic knowledge of its operation and the traffic requirements of our water wonderways.

# Antique Outboard News

SOUTHERN CALIFORNIA CHAPTER



AOMC/George Kent  
1240 Logan ave.  
Costa Mesa Ca. 92626

Fowler, Frank  
4918 Coldbrook  
Lakewood, CA 90713

## THE SOURCE

### OMC PARTS

**LEE'S MARINE**  
13910 Struikman Rd., Cerritos, CA  
Telephone 714-739-1003  
**SEA-WAY MARINE, INC.**  
2505 HARBOR AVENUE, S.W. Seattle,  
Washington, 98126  
Telephone 206-937-7373  
**COAST OUTBOARDS**  
**RICK CALVIN**  
51 K Street  
Chula Vista, California  
Telephone 619-498-1220

### MARTIN PARTS

**RUSS LARSON**  
1499 County Road #11  
Mead, NE 68041-0449  
Phone: 402-624-2345

### SCOTT ATWATER PARTS

**DON WEBB**  
340 Dry Bridge Road  
Mexico, NY 13115  
Telephone: 315-298-5708

### MERCURY PARTS

**BELK'S MARINE SUPPLY, INC.**  
2014 Parker Ave.,  
Holmes, PA 19043-1415  
Telephone: 610-532-4344  
**GRUBB'S MARINE**  
(send .33 for catalog)  
402 Walnut Street  
Spring City, PA 19475  
Telephone: 610-948-8855  
**DICK SHERRER MARINE, INC.**  
12328 E. Firestone Blvd.  
Norwalk, CA 90650  
Telephone: 562-868-9809

### ELGIN, SCOTT, WESTBEND PARTS

**LAING'S OUTBOARD MOTORS**  
Telephone 1-800-463-9001

### DECALS

**DECAL HEADQUARTERS**  
Telephone: 410-822-1740

### COAST OUTBOARDS

Telephone: 619-498-1220

### CATALOGS & MANUALS

**OMC manuals and parts catalogs**  
**KEN COOK CO.**  
P.O. Box 25355  
9929 W. Silver Springs Dr.  
Milwaukee, Wisconsin 53225  
**INTERTEC PUBLISHING**  
P.O. Box 12901  
Overland Park, KS 66282-2901  
Telephone: 1-800-262-1954  
Fax: 1-800-633-6219

### DON DWIGGINS

149 East Bay  
Atkins, Arkansas 72823  
Telephone: 501-641-2413

### PROPELLERS

**YORK PROPELLERS**  
**JOHN YORK**  
1631-B N. Placentia  
Anaheim, California 92806  
Telephone: 714-773-5444

### GAS TANK DENT REMOVAL

(Go through Jack Holtwick)  
Call Jack at:  
Telephone: 818-347-1987

### GASKETS

Vintage Motor Gaskets to fit Mercury  
Outboards 1959 and older. Call or write  
for catalog:  
**DOUG BROOKE**  
604 W. 19th  
Spokane, WA 99203  
Telephone: 509-747-0517

### RUBBER GRIPS

Send \$1.00 for catalog-5 to:  
**FOX GRIP, INC.**  
5181 Greencroft Dr.  
Dayton, Ohio 45426  
Telephone: 937-837-8783

### MAGNETOS

(Restore/Repair):  
**Jack Hurt**  
**J&M CAROUSEL**  
1711 Calavaras Drive  
Santa Rosa, CA 95405  
Ph/Fax: 707-544-1026  
Ph/Fax: 800-789-1026

The Antique Outboard Motor Club, Inc., Southern California Chapter  
Mail this application and \$25.00 to AOMC/George Kent, 1240 Logan St., Suite M, Costa Mesa, California 92626

### MEMBERSHIP APPLICATION

Name \_\_\_\_\_  
Address \_\_\_\_\_  
City \_\_\_\_\_ State \_\_\_\_\_ Zip \_\_\_\_\_  
Date \_\_\_\_\_ Telephone \_\_\_\_\_

What do you receive for your membership in our Southern California Chapter?

- Our local Chapter Newsletter. (Approximately 6 per year)
- Free classified ads in our Newsletter for both Wanted & For Sale items.
- Postal notification of all local dry and wet meets. (Approximately 6 per year)
- Members to help you find those difficult parts to locate and help you sell your unused items.
- A great group of outboard enthusiasts (approximately 100) with whom to socialize and have fun!
- Questions? Call (714) 751-2679 George Kent, Chapter President (E-Mail GNKIS@AOL.COM)